

100% CONSTRUCTION DOCUMENTS

# Site Development Plans

## South River Stream Bank Restoration

Land Lot 17, 16th District  
CITY OF STONECREST  
DEKALB COUNTY, GA

CLIENT:



City of Stonecrest  
3120 Stonecrest Blvd  
Stonecrest, GA 30038  
770-224-0200

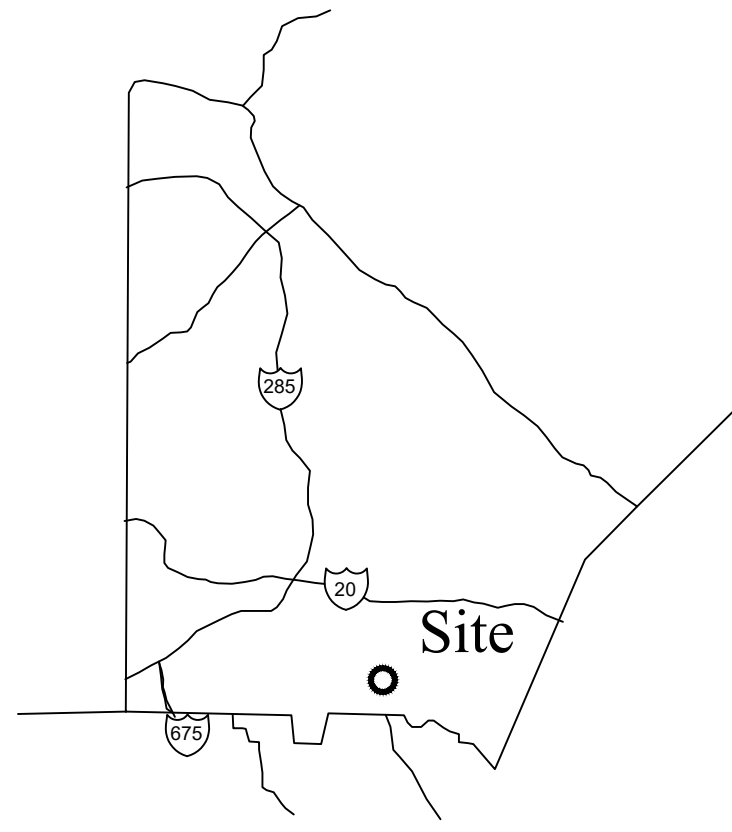

**Location Map**  
SCALE: N.T.S.

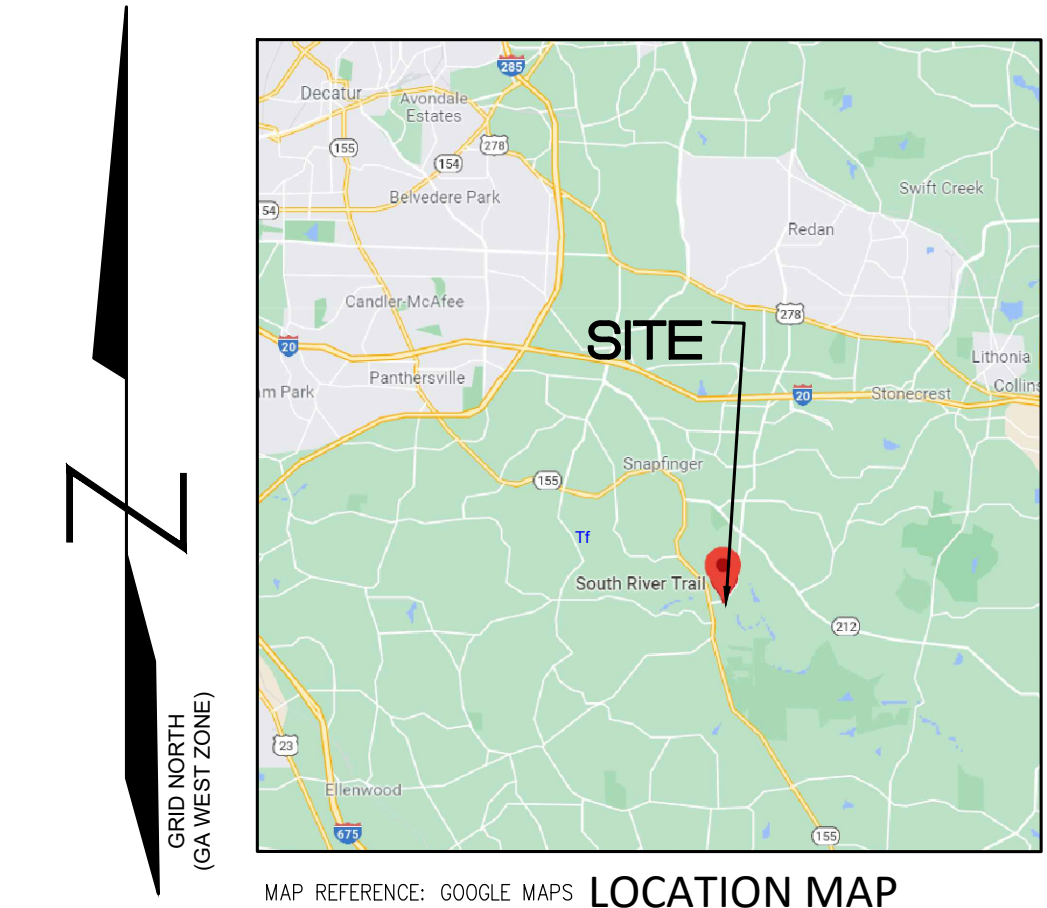

MAP REFERENCE: GOOGLE MAPS  
VICINITY MAP  
NOT TO SCALE  
**LOCATION MAP**

REVISIONS		
NO.	DATE	DESCRIPTION

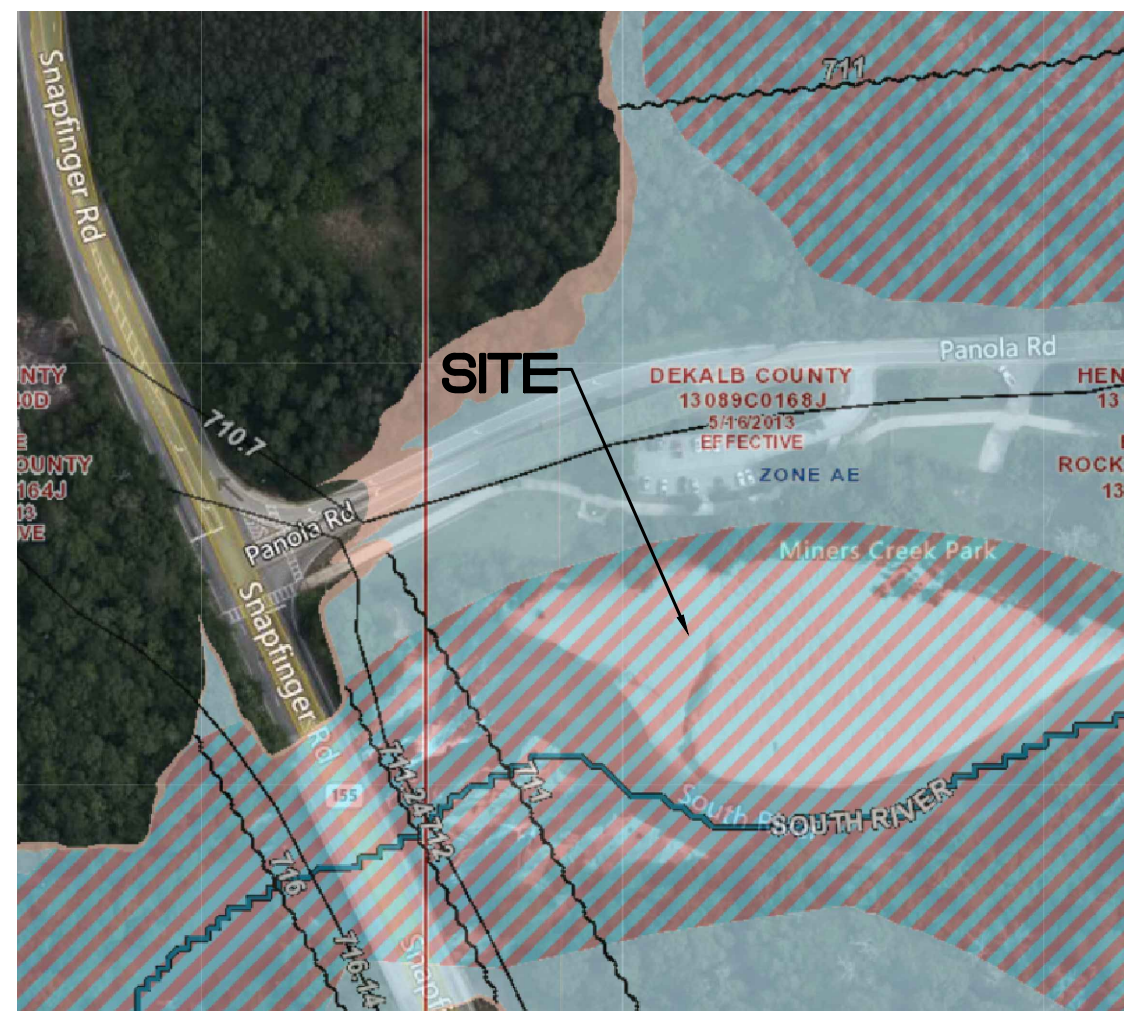

ACCORDING TO FEMA FLOOD INSURANCE RATE MAP # 13089C0168J DATED MAY 16, 2013, THIS SITE IS LOCATED WITHIN FLOOD ZONE AE.

**FEMA Map**

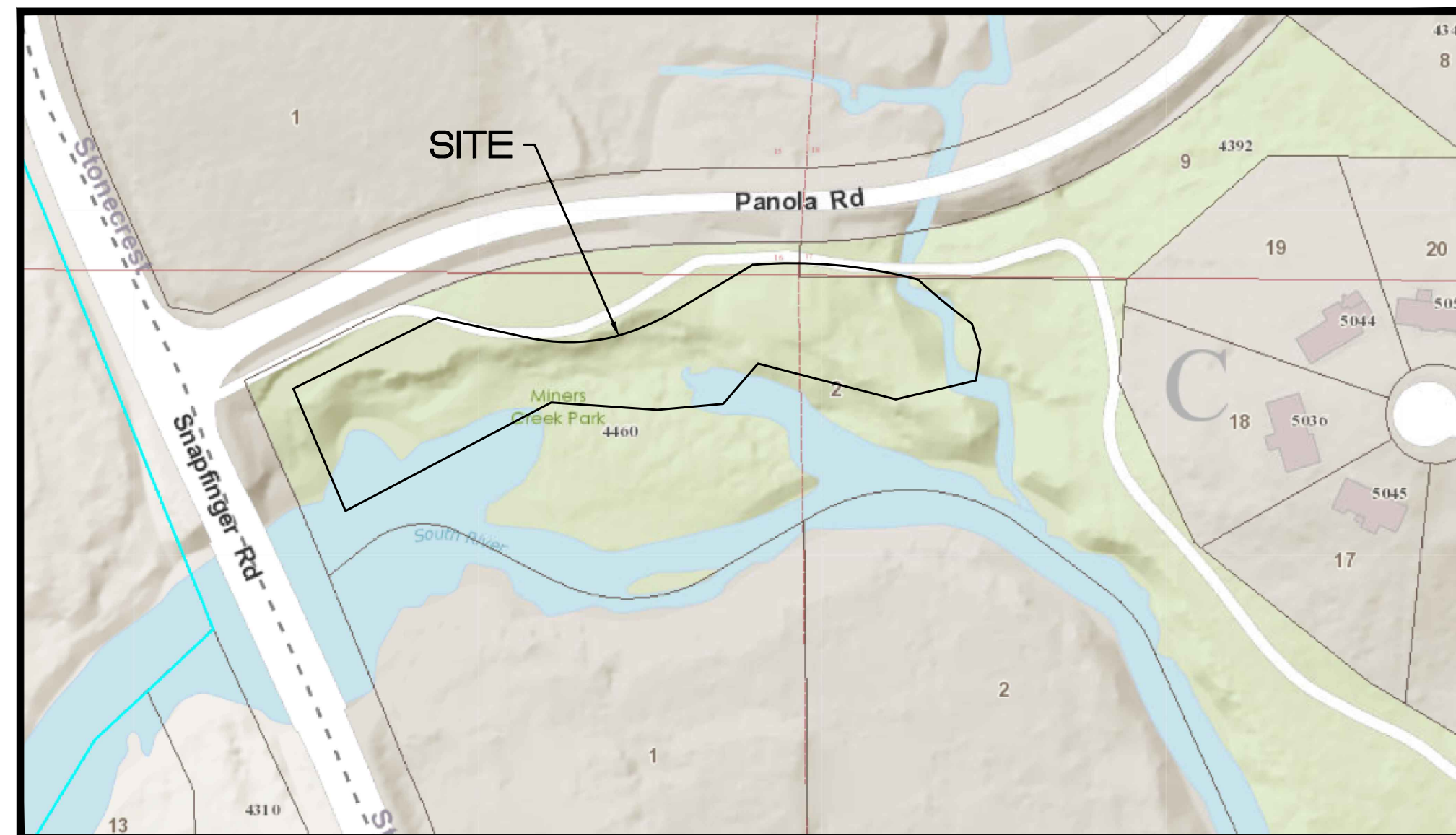

**Vicinity Map**  
SCALE: NTS

INDEX OF DRAWINGS	
DRAWING NO.	SHEET NAME
C-01-01	COVER SHEET
C-02-01	GENERAL NOTES & LEGEND
C-03-01	TOPOGRAPHIC SURVEY
C-03-02	BORING LAYOUT PLAN
C-04-01	CLEARING AND DEMOLITION PLAN
C-05-01	SITE PLAN
C-05-02	SURVEY CONTROL PLAN
C-05-03	SURVEY CONTROL PLAN CURVE TABLES
C-06-01	GRADING PLAN
C-06-02	WALL ENVELOPES AND PROFILES
C-06-03	WALL ENVELOPES AND PROFILES
C-06-04	WALL ENVELOPES AND PROFILES
C-07-01	CROSS-SECTIONS
C-08-01	NPDES POLLUTION PREVENTION PLAN
C-08-02	NPDES CHECKLIST
C-08-03	EROSION CONTROL PLAN- INITIAL PLAN
C-08-04	EROSION CONTROL PLAN- INTERMEDIATE PLAN
C-08-05	EROSION CONTROL PLAN- FINAL
C-08-06	EROSION CONTROL DETAILS
C-08-07	EROSION CONTROL DETAILS
C-08-08	EROSION CONTROL DETAILS
C-08-09	EROSION CONTROL DETAILS
C-09-01	CONSTRUCTION DETAILS
C-09-02	CONSTRUCTION DETAILS
C-14-01	LANDSCAPE PLAN - EAST
C-14-02	LANDSCAPE PLAN - WEST
C-15-01	IRRIGATION PLAN - EAST
C-15-02	IRRIGATION PLAN - WEST
C-15-03	IRRIGATION DETAILS
C-15-04	IRRIGATION DETAILS
C-15-05	IRRIGATION DETAILS

ENGINEER CERTIFICATION STATEMENTS:

"I CERTIFY UNDER PENALTY OF LAW THAT THIS PLAN WAS PREPARED AFTER A SITE VISIT TO THE LOCATIONS DESCRIBED HEREIN BY MYSELF OR MY AUTHORIZED AGENT, UNDER MY SUPERVISION."

"I CERTIFY THAT THE PERMITTEE'S EROSION, SEDIMENTATION AND POLLUTION CONTROL PLAN PROVIDES FOR AN APPROPRIATE AND COMPREHENSIVE SYSTEM OF BEST MANAGEMENT PRACTICES REQUIRED BY THE GEORGIA WATER QUALITY CONTROL ACT AND THE DOCUMENT "MANUAL FOR EROSION AND SEDIMENT CONTROL IN GEORGIA" (MANUAL) PUBLISHED BY THE STATE SOIL AND WATER CONSERVATION COMMISSION AS OF JANUARY 1 OF THE YEAR IN WHICH THE LAND-DISTURBING ACTIVITY WAS PERMITTED, PROVIDES FOR THE SAMPLING OF THE RECEIVING WATER(S) OR THE SAMPLING OF THE STORM WATER OUTFALLS AND THAT THE DESIGNED SYSTEM OF BEST MANAGEMENT PRACTICES AND SAMPLING METHODS IS EXPECTED TO MEET THE REQUIREMENTS CONTAINED IN THE GENERAL NPDES PERMIT NO. GAR 100001."

\_\_\_\_\_  
NAME                      COMPANY                      ADDRESS                      DATE

**PROJECT DESCRIPTION**

THE PURPOSE OF THIS PROJECT IS TO RESTORE THE ERODED PORTIONS OF THE STREAM BANK AND STABILIZE THE EMBANKMENT WITH A MIX OF HARDSCAPE AND LANDSCAPE TO PREVENT FUTURE EROSION. THIS PROJECT ENTAILS THE CONSTRUCTION OF A BLOCK WALL ALONG THE MOST CRITICAL AREAS (NEAR THE WALKING TRAIL AND PARKING LOT), A TWO-TIERED BOULDER WALL WITH NATIVE PLANTINGS AND AN ADA COMPLIANT RAMP TO LAUNCH KAYAKS, CANOES OR OTHER WATERCRAFT INTO THE SOUTH RIVER.



1990 Lakeside Parkway  
Suite 300  
Tucker, GA, 30084  
O: 678.999.0173  
F: 678.999.0186  
[www.cerm.com](http://www.cerm.com)

PANOLA SHOALS RIVERBANK STABILIZATION AND RESTORATION PROJECT  
TAX ID: 16 016 03 002  
LAND LOT 17 16th DISTRICT  
CITY OF STONECREST  
DEKALB COUNTY, GEORGIA

DESIGN TEAM	
DESIGN BY	CN
DRAWN BY	JD
CHECKED BY	YM
CERM PROJECT NO. 1468A-000A	
CLIENT PROJECT NO. 21-06210-Co018-00	
<b>DATE</b>	
JUNE 29, 2022	
<b>SHEET TITLE</b>	
COVER SHEET	
<b>SHEET No</b>	
C-01-01	



**Soil Map**  
PRIOR TO DIGGING VERIFY LOCATION OF EXISTING UTILITIES AND CONTACT GEORGIA 811  
<https://www.georgia811.com/>



Yasmin Moreno  
Level II Certified Design Professional  
CERTIFICATION NUMBER: 0000029509  
ISSUED: 06/27/2021      EXPIRES: 06/27/2024

**OWNER / DEVELOPER**  
CITY OF STONECREST  
3120 STONECREST BLVD.  
STONECREST, GA 30038  
TEL: 770.224.0200  
CONTACT: HARI KARIKARAN  
EMAIL: hkarikaran@stonecrestga.gov  
www.stonecrestga.gov

**ENGINEER**  
CERM  
1990 LAKESIDE PARKWAY STE 300  
TUCKER, GA 30084  
TEL: 678-999-0173  
CONTACT: YASMIN MORENO, P.E.  
EMAIL: ymoreno@cerm.com  
www.cerm.com

**24 HOUR EROSION CONTROL CONTACT:**  
NAME: 24 HOUR CONTACT  
JONATHAN WALKER  
404-546-3793

TOTAL DISTURBED ACRES = 1.33



Know what's below.  
Call before you dig.

72 HRS NOTICE IS REQUIRED TO GEORGIA 811 UTILITY PROTECTION CENTER BEFORE ANY PLANNED DIGGING  
<http://www.georgia811.com>

G:\Project Operations\Projects\Active Projects\2021-1468A-000A City of Stonecrest South River Stream Bank Restoration\0 - Design Documents\02 Plans\C-01 Cover Sheet.dwg Jul 06, 2022 - 5:26pm

**GENERAL NOTES**

1. WORK TO BE PERFORMED ON THIS PROJECT INCLUDES RESTORING THE ERODED PORTIONS OF THE STREAM BANK AND STABILIZE THE EMBANKMENT. INSTALLATION OF A PERMANENT BLOCK WALL, A TWO-TIERED BOULDER WALL WITH NATIVE PLANTINGS, AN ADA COMPLIANT RAMP, GRASSING, HARDSCAPE AND LANDSCAPE. IT ALSO INCLUDES THE REMOVAL AND REPLACEMENT OF EXISTING CHAIN LINK FENCE.
2. PROJECT IS LOCATED IN THE CITY OF STONECREST, ALONG A PUBLIC PARK AND RECREATION AREA. THE GENERAL PUBLIC AND NEARBY RESIDENTIAL HOMEOWNERS SHALL BE NOTIFIED AT LEAST TWO WEEKS PRIOR TO CONSTRUCTION.
3. CONSTRUCTION ACTIVITIES SHALL BE CARRIED OUT BETWEEN 9AM TO 5PM MONDAY TO FRIDAY. WORK OUTSIDE OF THESE HOURS MUST BE PRE-APPROVED BY THE CITY OF STONECREST.
4. NOTIFY THE CITY OF STONECREST AT LEAST 72 HOURS PRIOR TO BEGINNING LAND DISTURBANCE.
5. THE EXISTENCE AND LOCATIONS OF ALL BOUNDARIES, PROPERTY LINES, AND RIGHT-OF-WAY LINES REPRESENTED WITHIN THESE CONSTRUCTION DOCUMENTS ARE APPARENT, AND ARE BASED ON FIELD INVESTIGATION. CONTRACTOR IS TO VERIFY EACH, AS APPROPRIATE, PRIOR TO LAND DISTURBANCE OR CONSTRUCTION ACTIVITY.
31. ALL CONSTRUCTION MATERIALS, DETAILS AND METHODS SHALL CONFORM TO CITY OF STONECREST STANDARD SPECIFICATIONS AND CONSTRUCTION DETAILS, LATEST EDITION UNLESS OTHERWISE NOTED ON THE PLANS.
32. ALL WORK PERFORMED AND/OR RELATED CONSTRUCTION WITHIN THE ROW SHALL BE RETURNED TO PRE-EXISTING CONDITIONS OR BETTER PER CITY OF STONECREST STANDARDS.
33. ALL WORK PERFORMED AND/OR RELATED TO THE CONSTRUCTION ON PRIVATE PROPERTY SHALL BE RETURNED TO PRE-EXISTING CONDITIONS OR BETTER TO THE SATISFACTION OF THE ENGINEER AND/OR PROPERTY OWNER.
34. CONTRACTOR SHALL BE RESPONSIBLE FOR COMPLIANCE WITH EROSION CONTROL REQUIREMENTS OF THE LOCAL LAND DISTURBANCE PERMIT AND NPDES PERMIT.
35. CONTRACTOR IS RESPONSIBLE FOR REMOVING AND DISPOSING OF ALL CONSTRUCTION DEBRIS IN A LAWFUL MANNER.
36. ALL FILL MATERIAL TO BE COMPACTED TO 95% MAXIMUM DRY DENSITY, STANDARD PROCTOR (COMPACT FILL MATERIAL IN 6" LOOSE LIFTS)
37. EXISTING UTILITIES SHOWN ON THE DRAWINGS ARE BASED UPON THE BEST AVAILABLE INFORMATION. IT SHALL BE THE CONTRACTOR'S RESPONSIBILITY TO FIELD VERIFY EXISTING UTILITY LOCATIONS PRIOR TO CONSTRUCTION.
38. CONTRACTOR SHALL NOTIFY GA 811 ONE CALL CENTER AT LEAST 72 HOURS BEFORE EXCAVATING. CONTRACTOR TO NOTIFY UTILITY LOCATOR SERVICES FIVE (5) DAYS PRIOR TO EXCAVATION. THE CONTRACTOR SHALL OUTLINE THE LIMITS OF EXCAVATION WITH WHITE PAINT PRIOR TO THE ARRIVAL OF THE UTILITY LOCATOR.
39. CONTRACTOR SHALL BE RESPONSIBLE FOR SITE SECURITY AND JOB SAFETY. CONSTRUCTION ACTIVITIES SHALL BE IN ACCORDANCE WITH OSHA STANDARDS AND CITY OF STONECREST REQUIREMENTS.
40. UPON AWARD OF CONTRACT, CONTRACTOR SHALL MAKE NECESSARY CONSTRUCTION NOTIFICATIONS AND APPLY FOR AND OBTAIN NECESSARY PERMITS, PAY FEES, AND POST BONDS ASSOCIATED WITH THE WORK INDICATED ON THE DRAWINGS, IN THE SPECIFICATIONS, AND IN THE CONTRACT DOCUMENTS. DO NOT CLOSE OR OBSTRUCT ROADWAYS, SIDEWALKS, AND FIRE HYDRANTS WITHOUT APPROPRIATE PERMITS OR GOVERNMENT APPROVAL.
41. TRAFFIC SIGNAGE AND PAVEMENT MARKINGS SHALL CONFORM TO THE MANUAL OF UNIFORM TRAFFIC CONTROL DEVICES, UNLESS OTHERWISE INDICATED.
42. AREAS OUTSIDE THE LIMITS OF PROPOSED WORK DISTURBED BY THE CONTRACTOR'S OPERATIONS SHALL BE RESTORED BY THE CONTRACTOR TO THEIR ORIGINAL CONDITION AT THE CONTRACTOR'S EXPENSE AS SOON AS PRACTICABLE.
43. IN THE EVENT THAT SUSPECTED CONTAMINATED SOILS ARE ENCOUNTERED DURING EXCAVATION AND CONSTRUCTION ACTIVITIES BASED ON VISUAL, OLFACTORY, OR OTHER EVIDENCE, THE CONTRACTOR SHALL STOP WORK IN THE VICINITY OF THE SUSPECT MATERIAL TO AVOID FURTHER SPREADING OF THE MATERIAL, AND SHALL NOTIFY THE OWNER IMMEDIATELY SO THAT THE APPROPRIATE TESTING AND SUBSEQUENT ACTION CAN BE TAKEN.
44. CONTRACTOR SHALL PREVENT DUST, SEDIMENT, AND DEBRIS FROM EXITING THE SITE AND SHALL BE RESPONSIBLE FOR CLEANUP, REPAIRS AND CORRECTIVE ACTION IF SUCH OCCURS. CONTRACTOR SHALL DISPOSE OF DEBRIS IN ACCORDANCE WITH APPLICABLE FEDERAL, STATE, AND LOCAL REGULATIONS, ORDINANCES, AND STATUTES.
45. DAMAGE RESULTING FROM CONSTRUCTION LOADS SHALL BE REPAIRED BY THE CONTRACTOR AT NO ADDITIONAL COST TO THE CITY OF STONECREST.
46. CONTRACTOR SHALL CONTROL STORMWATER RUNOFF DURING CONSTRUCTION TO PREVENT ADVERSE IMPACTS TO OFF SITE AREAS, AND SHALL BE RESPONSIBLE TO REPAIR RESULTING DAMAGES, IF ANY, AT NO COST TO THE CITY. ALL PAVEMENT, DITCHES, CURB AND GUTTER, UTILITIES, DRIVEWAYS, SIDEWALKS, SIGNS, FENCES, ETC. DISTURBED DURING CONSTRUCTION SHALL BE REPAIRED AND/OR RESTORED TO THE SATISFACTION OF THE ENGINEER.
47. ALL ON SITE VEHICLE TRANSPORTATION ROUTES SHALL BE TEMPORARILY STABILIZED WITH STONE IMMEDIATELY AFTER GRADING TO PROVIDE READY ACCESS FOR EMERGENCY VEHICLES TO TRAVEL THROUGH AND AROUND CONSTRUCTION SITE DURING BOTH DRY AND WET WEATHER.
48. EXCESS EXCAVATION MATERIAL SHALL BE LEGALLY DISPOSED OF OFF SITE BY THE CONTRACTOR. NO SPOILS SHALL BE STORED ON SITE BEYOND SUBSTANTIAL COMPLETION.
49. CONTRACTOR IS RESPONSIBLE FOR THE COORDINATION AND SEQUENCING OF DEMOLITION AS DESCRIBED BY THESE DOCUMENTS AND SPECIFICATIONS. CONTRACTOR IS TO OBTAIN ALL PERMITS.
50. CONTRACTOR IS RESPONSIBLE FOR COORDINATION OF DEMOLITION OR RELOCATION WITH APPLICABLE UTILITY COMPANIES, I.E., GAS, CABLE, POWER, TELEPHONE, WATER, SEWER, ETC.
51. EQUIPMENT OPERATION, ACTIVITIES, OR PROCESSES PERFORMED BY THE CONTRACTOR SHALL BE IN ACCORDANCE WITH ALL FEDERAL AND STATE AIR EMISSION AND PERFORMANCE LAWS AND STANDARDS.
52. SOLID WASTES (EXCLUDING CLEARING DEBRIS) SHALL BE PLACED IN CONTAINERS WHICH ARE EMPTIED ON A REGULAR SCHEDULE. HANDLING, STORAGE, AND DISPOSAL SHALL BE CONDUCTED TO PREVENT CONTAMINATION. SEGREGATION MEASURES SHALL BE EMPLOYED SO THAT NO HAZARDOUS OR TOXIC WASTE WILL BECOME CO-MINGLED WITH SOLID WASTE. THE CONTRACTOR SHALL TRANSPORT SOLID WASTE OFF GOVERNMENT PROPERTY AND DISPOSE OF IT IN COMPLIANCE WITH FEDERAL, STATE AND LOCAL REQUIREMENTS FOR SOLID WASTE DISPOSAL. A SUBTITLE D PERMITTED LANDFILL SHALL BE THE MINIMUM ACCEPTABLE OFF-SITE SOLID WASTE DISPOSAL OPTION. THE CONTRACTOR SHALL VERIFY THAT THE SELECTED TRANSPORTERS AND DISPOSAL FACILITIES HAVE THE NECESSARY PERMITS AND LICENSES TO OPERATE. THE CONTRACTOR SHALL COMPLY WITH FEDERAL, STATE AND LOCAL LAWS AND REGULATIONS PERTAINING TO THE USE OF LANDFILL AREAS.
53. PRIOR TO COMMENCING CONSTRUCTION ACTIVITIES, THE CONTRACTOR SHALL MARK THE PROJECT LIMITS AS SHOWN ON THE PLANS. ISOLATED AREAS WITHIN THE GENERAL WORK AREA WHICH ARE NOT TO BE DISTURBED SHALL BE MARKED OR FENCED. MONUMENTS AND MARKERS SHALL BE PROTECTED BEFORE CONSTRUCTION OPERATIONS COMMENCE.
54. THE CONTRACTOR SHALL MONITOR CONSTRUCTION ACTIVITIES TO PREVENT POLLUTION OF SURFACE AND GROUND WATERS AND SHALL COMPLY WITH THE CLEAN WATER ACT SECTION 404 REGULATIONS.
55. CONTRACTOR SHALL ESTABLISH AND VERIFY POINT OF BEGINNING (P.O.B) AND STAKE SITE AS INDICATED ON CONSTRUCTION DOCUMENTS PRIOR TO COMMENCEMENT OF CONSTRUCTION. NOTIFY THE ENGINEER IMMEDIATELY OF ANY DISCREPANCIES.
56. ALL EXCAVATIONS MUST BE PERFORMED SO THAT THE SITE AND THE AREA IMMEDIATELY SURROUNDING THE SITE WHICH AFFECTS CONSTRUCTION OPERATIONS WILL BE CONTINUALLY AND EFFECTIVELY DRAINED. THE CONTRACTOR MUST PROVIDE DRAINAGE AND DEWATERING AS REQUIRED TO ENSURE THAT ALL FOOTING EXCAVATIONS ARE ACCOMPLISHED WITH THE SUBGRADE SOILS REMAINING DRY AND FIRM UNTIL AFTER FOOTINGS ARE PLACED AND BACKFILLED. REMOVAL OF SURFACE WATER, GROUNDWATER, AND ANY PERCHED WATER CONDITIONS, WHICH MIGHT BE ENCOUNTERED DURING EXCAVATIONS, SHALL BE ACCOMPLISHED BY APPROVED MEANS. REFER TO GDOT STANDARD SPECIFICATIONS - EARTHWORK FOR ADDITIONAL REQUIREMENTS.
57. CONTRACTOR SHALL FIELD-VERIFY ALL DIMENSIONS SHOWN ON PLANS. ANY DISCREPANCIES SHALL BE BROUGHT TO THE ATTENTION OF THE ENGINEER OR OWNER FOR CORRECTION.

**STORMWATER MANAGEMENT NOTES**

1. THIS PROJECT IS WITHIN A REGULATORY FLOODWAY. BASE FLOOD ELEVATION IS 711.

**LAYOUT NOTES**

1. PRIOR TO START OF CONSTRUCTION, CONTRACTOR SHALL VERIFY EXISTING GROUND ELEVATIONS ADJACENT TO DRAINAGE OUTLETS TO ASSURE PROPER TRANSITIONS BETWEEN EXISTING AND PROPOSED FACILITIES.
2. SYMBOLS AND LEGENDS OF PROJECT ARE GRAPHIC REPRESENTATIONS AND ARE NOT NECESSARILY SCALED TO THEIR ACTUAL DIMENSIONS OR LOCATIONS ON THE DRAWINGS. THE CONTRACTOR SHALL REFER TO THE DETAIL SHEET DIMENSIONS, MANUFACTURER'S LITERATURE, SHOP DRAWINGS, AND FIELD MEASUREMENTS OF SUPPLIED PRODUCTS FOR LAYOUT OF THE PROJECT FEATURES.
3. CONTRACTOR SHALL NOT RELY SOLELY ON ELECTRONIC VERSIONS OF PLANS, SPECIFICATIONS, AND DATA FILES THAT ARE OBTAINED FROM THE DESIGNERS, BUT SHALL VERIFY LOCATION OF PROJECT FEATURES IN ACCORDANCE WITH THE PAPER COPIES OF THE PLANS AND SPECIFICATIONS THAT ARE SUPPLIED AS PART OF THE CONTRACT DOCUMENTS AND PERMIT STAMPED BY THE CITY OF STONECREST.

**TRAFFIC CONTROL AND PHASING NOTES**

1. CONTRACTOR IS RESPONSIBLE FOR TRAFFIC CONTROL DURING CONSTRUCTION. THE CONTRACTOR SHALL SUBMIT A TRAFFIC CONTROL PLAN TO THE ENGINEER FOR APPROVAL AT LEAST TWO WEEKS BEFORE COMMENCEMENT OF WORK.
2. CONTRACTOR SHALL INSTALL CAUTION SIGNS AS NEEDED DURING CONSTRUCTION OR AS DIRECTED BY THE ENGINEER.
3. CONTRACTOR SHALL SEEK TO MINIMIZE TRAFFIC DISRUPTION TO GENERAL PUBLIC AND RESIDENTS
4. ACCESS TO PUBLIC PARK & RECREATION AREAS AND RESIDENTIAL PROPERTIES MUST BE MAINTAINED AT ALL TIMES.

**EROSION CONTROL NOTES:**

- 1) THE ESCAPE OF SEDIMENT FROM THE SITE SHALL BE PREVENTED BY THE INSTALLATION OF EROSION AND SEDIMENT CONTROL MEASURES AND PRACTICES PRIOR TO, OR CONCURRENT WITH LAND DISTURBING ACTIVITIES.
- 2) EROSION CONTROL MEASURES WILL BE MAINTAINED AT ALL TIMES. IF FULL IMPLEMENTATION OF THE APPROVED PLAN DOES NOT PROVIDE FOR EFFECTIVE EROSION CONTROL, ADDITIONAL EROSION AND SEDIMENTATION CONTROL MEASURES SHALL BE IMPLEMENTED TO CONTROL OR TREAT THE SEDIMENT SOURCE.
- 3) SEDIMENT STORAGE MAINTENANCE INDICATORS MUST BE INSTALLED IN SEDIMENT STORAGE STRUCTURES INDICATING THE 1/2 FULL VOLUME.
- 4) MAINTENANCE OF ALL SOIL EROSION AND SEDEMENTATION CONTROL MEASURES AND PRACTICES, WHETHER TEMPORARY OR PERMANENT, SHALL BE AT ALL TIMES THE RESPONSIBILITY OF THE PROPERTY OWNER.
- 5) A 50-FOOT UNDISTURBED BUFFER AND A 75-FOOT IMPERVIOUS SETBACK IS TO BE MAINTAINED ADJACENT TO ALL STREAMS
- 6) WHERE APPROPRIATE, DETENTION POND, DETENTION OUTLET STRUCTURES, AND TEMPORARY SEDIMENT POND FEATURES ARE TO BE CONSTRUCTED AND FULLY OPERATIONAL PRIOR TO ANY OTHER CONSTRUCTION OR GRADING.
- 7) DISTURBED AREAS SHALL BE STABILIZED WITH TEMPORARY VEGETATION OR MULCH IF LAND DISTURBING ACTIVITIES CEASE FOR MORE THAN 14 CALENDAR DAYS
- 8) ALL FILL SLOPES SHALL HAVE SILT FENCE PLACED AT THE SLOPE'S TOE.
- 9) CONCENTRATED FLOW AREAS AND ALL SLOPES STEEPER THAN 2.5:1 WITH A HEIGHT OF 10 FEET OR GREATER SHALL BE STABILIZED WITH THE APPROPRIATE EROSION CONTROL MATTING OR BLANKET.
- 10) THE PROFESSIONAL WHO SEALS THIS PLAN CERTIFIES UNDER PENALTY OF LAW THAT THE THIS PLAN WAS PREPARED AFTER A SITE VISIT TO THE LOCATIONS DESCRIBED HEREIN BY THE PROFESSIONAL'S AUTHORIZED AGENT, UNDER THE PROFESSIONAL'S SUPERVISION
- 11) UPON NOTIFICATION AND AUTHORIZATION OF THE OWNER, THE DESIGN PROFESSIONAL WHO PREPARED THE ES&PC PLAN IS RESPONSIBLE FOR INSPECTING THE INSTALLATION OF THE BMP'S WITHIN 7 DAYS AFTER INITIAL CONSTRUCTION ACTIVITIES BEGINS.
- 12) GASWCC LEVEL II DESIGN PROFESSIONAL CERTIFICATION NUMBER IS 24059 AND SIGNATURE IS ATTACHED.
- 13) THE SOIL EROSION AND SEDIMENT CONTROL ORDINANCE REQUIRES THAT A 25 FOOT BUFFER ADJACENT TO ALL STATE WATERS BE MAINTAINED (ARTICLE 4 SECTION 4.3 PARAGRAPH 15), AN EXCEPTION IS GRANTED TO HOMEOWNERS WHO PERFORM MINOR LAND DISTURBING ACTIVITIES SUCH AS HOME LANDSCAPING, HOME GARDENS, AND MAINTENANCE WORK (ARTICLE 3, SECTION 3.1, PARAGRAPH 3).
- 14) ALL WORK SHALL BE PERFORMED IN ACCORDANCE WITH THE STANDARDS AND SPECIFICATIONS OF THE PUBLICATION ENTITLED "MANUAL FOR EROSION AND SEDIMENT CONTROL IN GEORGIA"
- 15) CONSTRUCTION ACTIVITIES WILL BE PERFORMED IN COMPLIANCE WITH ALL APPLICABLE LAWS, RULES, AND REGULATIONS.
- 16) TEMPORARY EROSION CONTROL DEVICES MUST BE IN PLACE AND OPERATIONAL PRIOR TO CLEARING AND GRADING OPERATIONS.
- 17) REPLACE CLOGGED SECTIONS OF SILT FENCES AS NECESSARY TO MAINTAIN WATER PASSAGE.
- 18) STABILIZE ALL SLOPES AND BARE AREAS AS SOON AS POSSIBLE AFTER GRADING OPERATIONS ARE COMPLETE.
- 19) SEDIMENT AND EROSION CONTROL MEASURES SHALL BE INSPECTED DAILY. ANY DAMAGES OBSERVED WILL BE REPAIRED BY END OF THE DAY.
- 20) STONE FOR CONSTRUCTION EXIT TO BE A.S.T.M D 448 SIZE#1 (1-1/2" TO 3-1/2" IN DIAMETER). THE EXIT MUST BE MAINTAINED IN CONDITION TO PREVENT TRACKING OR FLOW OF MUD FROM GRADING OPERATIONS. CONTRACTOR TO APPLY PERIODIC DRESSING TO CONSTRUCTION EXIT WITH #1 STONE AS REQUIRED.
- 21) PERMANENT EROSION CONTROL MUST BE ACHIEVED PRIOR TO REMOVAL OF TEMPORARY EROSION CONTROL DEVICES.
- 22) EROSION CONTROL DEVICES SHOWN HEREON ARE TO BE CONSIDERED A MINIMUM. ADDITIONAL MEASURES ARE TO BE INSTALLED IF DEEMED NECESSARY BY AN ON-SITE INSPECTION.
- 23) THE INSTALLATION OF EROSION AND SEDIMENT CONTROL MEASURES AND PRACTICES SHALL OCCUR PRIOR TO OR CONCURRENT WITH LAND DISTURBING ACTIVITIES.
- 24) CONTRACTOR TO PROVIDE WHEEL WASH AREA CLOSE TO THE CONSTRUCTION EXIT TO REMOVE EXCESS DIRT FROM CONSTRUCTION VEHICLES BEFORE ENTERING THE PUBLIC ROADWAY.
- 25) THE PRIMARY PERMITTEE MUST SAMPLE ALL RECEIVING WATER(S), OR ALL OUTFALL(S), OR A COMBINATION OF RECEIVING WATERS AND OUTFALL(S). RECEIVING WATERS MUST HAVE AN UPSTREAM AND A DOWNSTREAM SAMPLE LOCATION.
- 26) ANY DISTURBED AREA LEFT EXPOSED FOR A PERIOD GREATER THAN 14 DAYS SHALL BE STABILIZED WITH MULCH OR TEMPORARY SEEDING.

**OWNER / DEVELOPER**  
 CITY OF STONECREST  
 3120 STONECREST BLVD.  
 STONECREST, GA 30038  
 TEL: 770-224-0200  
 CONTACT: HARI KARIKARAN  
 EMAIL: hkarikaran@stonecrestga.gov  
 www.stonecrestga.gov

**ENGINEER**  
 CERM  
 1990 LAKESIDE PARKWAY STE 300  
 TUCKER, GA 30084  
 TEL: 678-999-0173  
 CONTACT: YASMIN MORENO, P.E.  
 EMAIL: ymoreno@cerm.com  
 www.cerm.com

**LEGEND**

- |  |        |                               |
|--|--------|-------------------------------|
|  | SD     | STORM SEWER                   |
|  | OE     | OVERHEAD ELECTRIC             |
|  | SS     | SANITARY SEWER LINE           |
|  | WF     | WOOD FENCE                    |
|  | GW     | GUY WIRE                      |
|  | PP     | POWER POLE (PP)               |
|  | SIGN   | SIGN                          |
|  | WV     | WATER VALVE (WV)              |
|  | WM     | WATER METER (WM)              |
|  | T      | TREES                         |
|  | TL     | TREELINE                      |
|  | CO     | CLEAN OUT (CO)                |
|  | SSMH   | SANITARY SEWER MANHOLE (SSMH) |
|  | R/W    | RIGHT-OF-WAY                  |
|  | P.L.   | PROPERTY LINE                 |
|  | AC     | AIR CONDITIONER               |
|  | MB     | MAIL BOX                      |
|  | WV     | WATER VAULT                   |
|  | HW     | HARDWOOD                      |
|  | DIP    | DUCTILE IRON PIPE             |
|  | PVC    | POLYVINYL CHLORIDE PIPE       |
|  | CPP    | CORRUGATED PLASTIC PIPE       |
|  | ASPH   | ASPHALT                       |
|  | CONC   | CONCRETE                      |
|  | GRAVEL | GRAVEL                        |
|  | MC     | MINOR CONTOUR                 |
|  | MA     | MAJOR CONTOUR                 |
|  | TK     | TERMINUS UNKNOWN              |

**ABBREVIATIONS**

- |        |                                |
|--------|--------------------------------|
| APN    | Assessor parcel number         |
| BOW    | Bottom of wall                 |
| C/L    | Center line                    |
| CB     | Catch basin                    |
| CLF    | Chain link fence               |
| CMP    | Corrugated metal pipe          |
| CONC.  | Concrete                       |
| DI     | Drain inlet                    |
| DIA.   | Diameter                       |
| DB     | Deed book                      |
| Exist. | Existing                       |
| FFE    | Finish floor elevation         |
| HDPE   | High density polyethylene pipe |
| Hor.   | Horizontal                     |
| IE     | Invert elevation               |
| L.F.   | Linear feet                    |
| MH     | Manhole                        |
| Min.   | Minimum                        |
| N/F    | Now or formerly                |
| No.    | Number                         |
| N.T.S  | Not to scale                   |
| OCS    | Outlet control structure       |
| OH     | Over head                      |
| PG     | Page                           |
| PI     | Pine                           |
| Prop.  | Proposed                       |
| PVC    | Polyvinyl chloride pipe        |
| R/W    | Right of way                   |
| S.F    | Square feet                    |
| SS     | Sanitary sewer                 |
| TOW    | Top of wall                    |
| Typ.   | Typical                        |
| Vert.  | Vertical                       |

C:\Project\_Operations\Projects\Active Projects\2021-1488A-000A\_City of Stonecrest\_South River\_Stream Bank\_Restoration\0 - Design Documents\02 Plans\C-02 General Notes & Legend.dwgJul 06, 2022 - 9:26am

CLIENT:  
  
 City of Stonecrest  
 3120 Stonecrest Blvd  
 Stonecrest, GA 30038  
 770-224-0200

REVISIONS		
NO.	DATE	DESCRIPTION

1990 Lakeside Parkway  
 Suite 300  
 Tucker, GA, 30084  
 O: 678.999.0173  
 F: 678.999.0186  
[www.cerm.com](http://www.cerm.com)

PROJECT: PANOLA SHOALS RIVERBANK STABILIZATION AND RESTORATION PROJECT  
 TAX ID: 16 016 03 002  
 LAND LOT 17 16th DISTRICT CITY OF STONECREST DEKALB COUNTY, GEORGIA

DESIGN TEAM	
DESIGN BY	CN
DRAWN BY	JD
CHECKED BY	YM

CERM PROJECT NO. 1468A-000A  
 CLIENT PROJECT NO. 21-06210-Co018-00

**DATE**  
 JUNE 29, 2022

**SHEET TITLE**  
 GENERAL NOTES & LEGEND

**SHEET No**  
**C-02-01**



LEGEND	
	STORM SEWER
	OVERHEAD ELECTRIC
	CHAIN LINK FENCE
	UTILITY/POWER POLE (UP)
	BOLLARD
	SIGN
	INVERT ELEVATION
	CORRUGATED METAL PIPE
	SPOT ELEVATION
	TREES
	HARDWOOD
	HEADWALL (HW)
	MINOR CONTOUR
	MAJOR CONTOUR
	ASPHALT
	CONCRETE
	TREE LINE

**GENERAL NOTES**

1. SURVEY PROCEDURES: THIS SURVEY IS BASED ON MEASUREMENTS OBTAINED USING A TRIMBLE ROBOTIC TOTAL STATION INSTRUMENT CAPABLE OF READING ANGULAR MEASUREMENTS DIRECTLY TO A MINIMUM OF 1 SECOND OF ARC AND LINEAR DIMENSIONS DIRECTLY TO 0.01 FEET AND TRIMBLE VX ROBOTIC SCANNING TOTAL STATION USING SMARTNET RTK NETWORK TECHNOLOGY.
2. THE FIELD SURVEY UPON WHICH THIS PLAN IS BASED WAS COMPLETED IN THE FIELD JUNE 15, 2020 AND THIS PLAN WAS PREPARED ON JULY 1, 2020.
3. THIS SURVEY WAS PERFORMED AT THE REQUEST OF:
4. THIS SURVEY WAS PREPARED FOR THE EXCLUSIVE USE OF THE PARTY OR ENTITY NAMED HEREON AND THE CERTIFICATION DOES NOT EXTEND TO ANY OTHERS.
5. THE VERTICAL DATUM IS BASED ON NAVD 88.
6. COORDINATES ARE BASED UPON THE STATE PLANE COORDINATE SYSTEM, GEORGIA WEST ZONE, NORTH AMERICAN DATUM OF 1983, ADJUSTMENT OF 2011, DERIVED FROM GLOBAL POSITIONING SYSTEM (GPS) DATA.
7. CERM AND/OR ERICK L. SMITH DOES NOT GUARANTEE THAT ALL EASEMENTS AND SUB-SURFACE CONDITIONS WHICH MAY AFFECT THIS PROPERTY ARE SHOWN.
8. THIS DRAWING HAS BEEN GENERATED ELECTRONICALLY. THIS MEDIA SHOULD NOT BE CONSIDERED A CERTIFIED VALID DOCUMENT UNLESS IT HAS BEEN PROPERLY SEALED, SIGNED, AND DATED BY ERICK L. SMITH.
9. ALL VARIOUS SANITARY AND STORM DRAIN STRUCTURES SHOWN HEREON, THERE ARE ADDITIONAL LINES ENTERING OR EXITING THE STRUCTURE. IN SOME CASES, THE ORIGIN OR DESTINATION OF THE LINE COULD NOT BE DETERMINED. THIS SURVEY DEPICTS THOSE LINES AND THE GENERAL DIRECTION OF THE LINE, HOWEVER, WITHOUT ADDITIONAL DATA OR BENEFIT OF EXCAVATION, THE LOCATION OF THESE LINES CANNOT BE DETERMINED.

**CERTIFICATION**

I HEREBY CERTIFY TO (NAME OF CLIENT) THAT ALL PARTS OF THIS SURVEY AND DRAWING HAVE BEEN COMPLETED IN ACCORDANCE WITH THE CURRENT REQUIREMENTS OF THE STANDARDS OF PRACTICE FOR SURVEYING IN THE STATE OF GEORGIA TO THE BEST OF MY KNOWLEDGE, INFORMATION, AND BELIEF.

OWNER / DEVELOPER  
 CITY OF STONECREST  
 3120 STONECREST BLVD.  
 STONECREST, GA 30038  
 TEL: 770-224-0200  
 CONTACT: HARI KARIKARAN  
 EMAIL: hkarikaran@stonecrestga.gov  
 www.stonecrestga.gov

ENGINEER  
 CERM  
 1990 LAKESIDE PARKWAY STE 300  
 TUCKER, GA 30084  
 TEL: 678-999-0173  
 CONTACT: YASMIN MORENO, P.E.  
 EMAIL: ymoreno@cerm.com  
 www.cerm.com

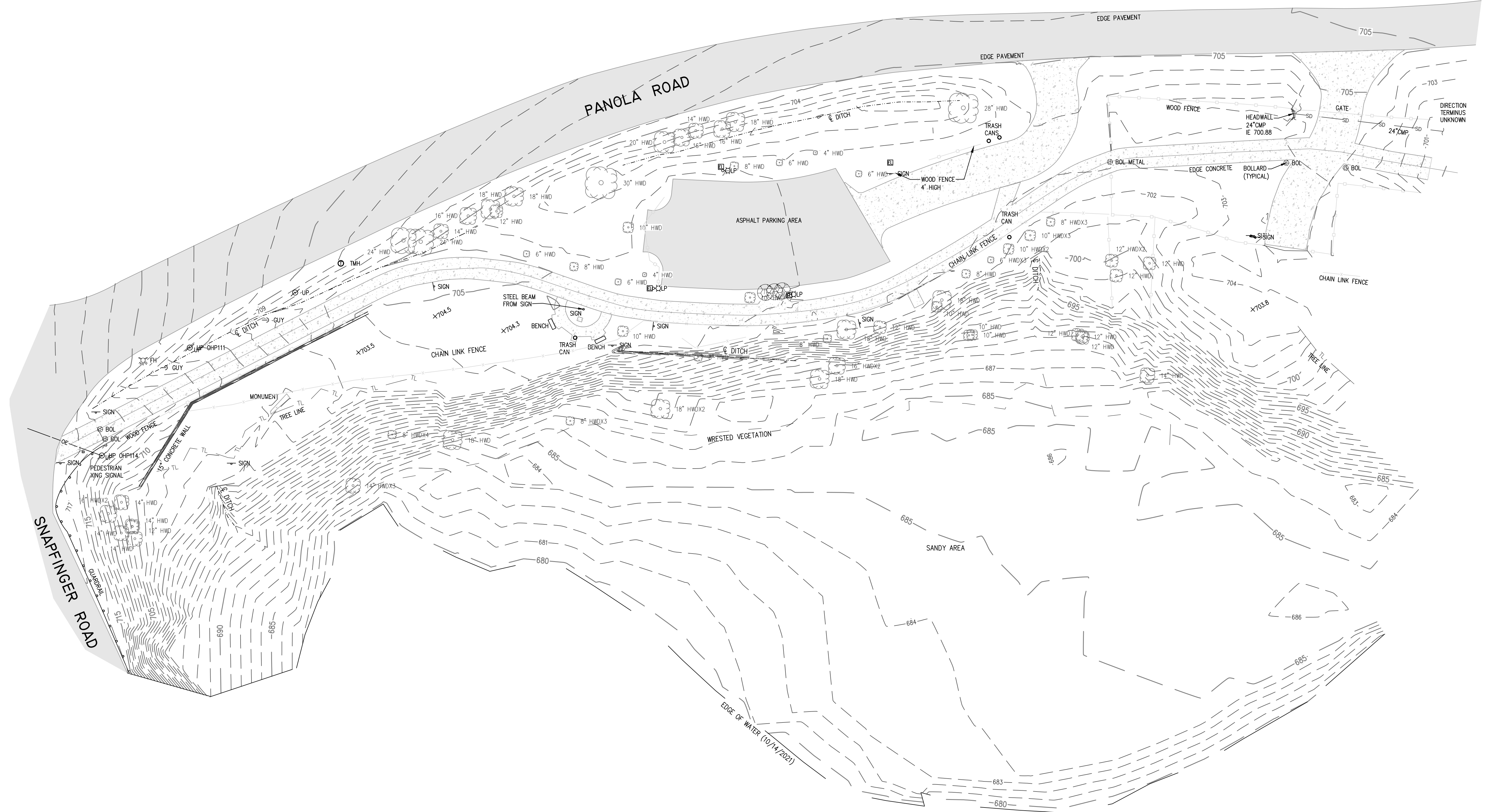
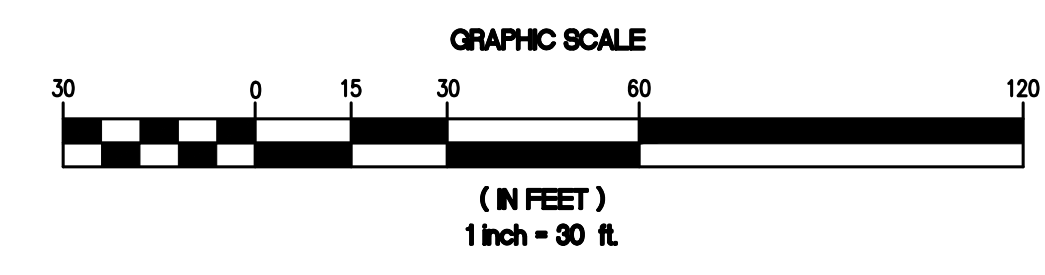
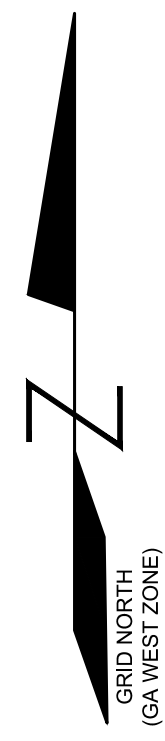

CLIENT:  
  
 City of Stonecrest  
 3120 Stonecrest Blvd  
 Stonecrest, GA 30038  
 770-224-0200

REVISIONS		
NO.	DATE	DESCRIPTION

CERM  
 1990 Lakeside Parkway  
 Suite 300  
 Tucker, GA, 30084  
 O: 678.999.0173  
 F: 678.999.0186  
[www.cerm.com](http://www.cerm.com)

PROJECT:  
 PANOLA SHOALS RIVERBANK STABILIZATION  
 AND RESTORATION PROJECT  
 TAX ID: 16 016 03 002  
 LAND LOT 17 16th DISTRICT  
 CITY OF STONECREST  
 DEKALB COUNTY, GEORGIA

DESIGN TEAM	
DESIGN BY	CN
DRAWN BY	JD
CHECKED BY	YM

CERM PROJECT NO. 1468A-000A  
 CLIENT PROJECT NO. 21-06210-Co018-00

DATE  
 JUNE 29, 2022  
 SHEET TITLE

TOPOGRAPHIC  
 SURVEY

SHEET No  
 C-03-01



C:\Project Operations\Projects\Active Projects\2021-1468A-000A City of Stonecrest South River Stream Bank Restoration\40 - Design Documents\02 Plans\C-03 Existing Conditions.dwg Jul 06, 2022 -- 5:27pm

**LEGEND**

SD	STORM SEWER
OE	OVERHEAD ELECTRIC
CLF	CHAIN LINK FENCE
UP	UTILITY/POWER POLE (UP)
BOL	BOLLARD
IE	INVERT ELEVATION
CMP	CORRUGATED METAL PIPE
x 630.5	SPOT ELEVATION
TREES	TREES
HWD	HARDWOOD
HW	HEADWALL (HW)
MC	MINOR CONTOUR
MAJ	MAJOR CONTOUR
ASP	ASPHALT
CON	CONCRETE
TL	TREE LINE
BOR	BORING

**OWNER / DEVELOPER**  
 CITY OF STONECREST  
 3120 STONECREST BLVD.  
 STONECREST, GA 30038  
 TEL: 770-224-0200  
 CONTACT: HARI KARIKARAN  
 EMAIL: hkarikaran@stonecrestga.gov  
 www.stonecrestga.gov

**ENGINEER**  
 CERM  
 1990 LAKESIDE PARKWAY STE 300  
 TUCKER, GA 30084  
 TEL: 678-999-0173  
 CONTACT: YASMIN MORENO, P.E.  
 EMAIL: ymoreno@cerm.com  
 www.cerm.com

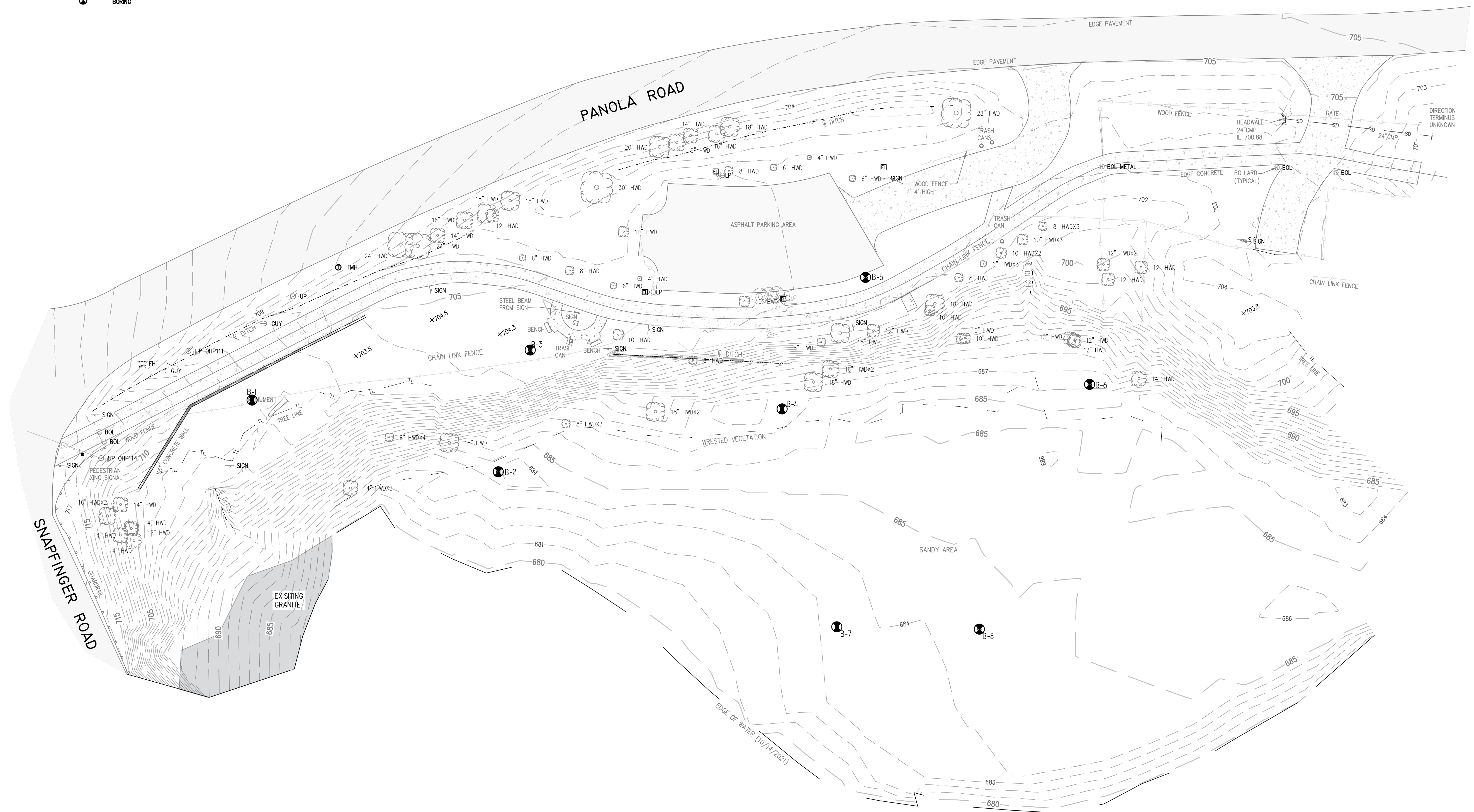
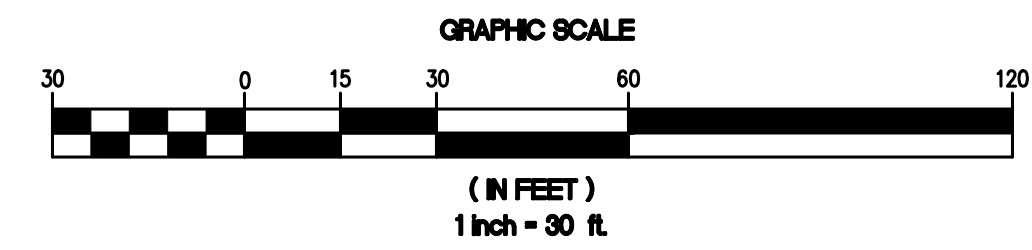
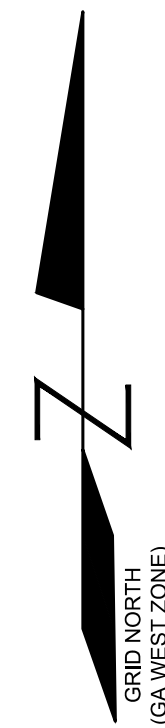

G:\Project Operations\Projects\Active Projects\2021-1468A-000A City of Stonecrest South River Stream Bank Restoration\40 - Design Documents\02 Plans\C-03 Existing Conditions.dwg Jul 06, 2022 - 5:27pm

CLIENT:  
  
 City of Stonecrest  
 3120 Stonecrest Blvd  
 Stonecrest, GA 30038  
 770-224-0200

REVISIONS		
NO.	DATE	DESCRIPTION

  
**C · E · R · M**  
 1990 Lakeside Parkway  
 Suite 300  
 Tucker, GA, 30084  
 O: 678.999.0173  
 F: 678.999.0186  
[www.cerm.com](http://www.cerm.com)

PROJECT:  
 PANOLA SHOALS RIVERBANK STABILIZATION  
 AND RESTORATION PROJECT  
 TAX ID: 16 016 03 002  
 LAND LOT 17 16th DISTRICT  
 CITY OF STONECREST  
 DEKALB COUNTY, GEORGIA

DESIGN TEAM	
DESIGN BY	CN
DRAWN BY	JD
CHECKED BY	YM

CERM PROJECT NO. 1468A-000A  
 CLIENT PROJECT NO. 21-06210-Co018-00

**DATE**  
 JUNE 29, 2022

**SHEET TITLE**  
 BORING  
 LAYOUT PLAN

**SHEET No**  
 C-03-02

 PRIOR TO DIGGING  
 VERIFY LOCATION  
 OF EXISTING UTILITIES  
 AND CONTACT GEORGIA 811  
<https://www.georgia811.com/>

C:\Project Operations\Projects\Active Projects\2021-1468A-000A City of Stonecrest South River Stream Bank Restoration\0 - Design Documents\02 Plans\C-04 Clearing and Demo Plan.dwg, Jul 06, 2022 - 5:27pm

**LEGEND**

- SD STORM SEWER
- OE OVERHEAD ELECTRIC
- CLF CHAIN LINK FENCE
- UP UTILITY/POWER POLE (UP)
- BOL BOLLARD
- SIGN SIGN
- IE INVERT ELEVATION
- CMP CORRUGATED METAL PIPE
- SPOT ELEVATION
- TREES
- HWD HARDWOOD
- HW HEADWALL (HW)
- MINOR CONTOUR
- MAJOR CONTOUR
- ASPHALT
- EXISTING PAVEMENT

**DEMOLITION KEYNOTES:**

1. DEMOLISH BUILDING
2. ASPHALT TO BE REMOVED
3. CONCRETE TO BE REMOVED
4. REMOVE BOLLARDS
5. REMOVE GARD READER AND GATE
6. REMOVE SIGN
7. DEMOLISH WALL
8. SAWCUT PAVEMENT

**LEGEND**

- FENCE TO BE REMOVED
- CURB AND GUTTER TO BE REMOVED
- WALL TO BE REMOVED
- ASPHALT TO BE REMOVED
- CONCRETE TO BE REMOVED
- TREE TO BE REMOVED
- PROJECT LIMITS
- LIMIT OF DISTURBANCE

**DEMOLITION NOTES**

1. ALL LAND DISTURBANCE TO BE STABILIZED WITH VEGETATION UPON COMPLETION OF DEMOLITION AND EXISTING PAVEMENT SHALL BE RESTORED TO ORIGINAL CONDITION OR BETTER.
2. ALL TREES TO REMAIN AND SHALL HAVE PROPER PROTECTION UNLESS APPROVED PLANS INDICATE OTHERWISE.
3. ALL DEMOLITION DEBRIS TO BE HAULED OFF SITE.
4. DUMPSTERS AND/OR TEMPORARY SANITARY FACILITIES SHALL NOT BE LOCATED IN THE STREET OR TREE PROTECTION AREA OR OTHER RIGHT-OF-WAY.
5. ADDITIONAL EROSION CONTROLS SHALL BE INSTALLED AS DEEMED NECESSARY BY THE ON-SITE INSPECTOR(S).
6. CALL FOR FINAL INSPECTION AT (???) ???-????

**NOTES**

1. SILT FENCE AND CONSTRUCTION EXIT MUST BE IN PLACE PRIOR TO START OF CONSTRUCTION ACTIVITIES.
2. ALL MATERIAL MUST BE CARTED OFF SITE AND DISPOSED AT AN APPROVED LANDFILL IN ACCORDANCE WITH LOCAL AND STATE REGULATIONS.
3. PRIOR TO ANY LAND DISTURBING ACTIVITIES, CONTRACTOR SHALL LOCATE AND FLAG ALL UNDERGROUND UTILITIES INCLUDING WATER, GAS, ELECTRIC, AND SEWER LINES. DEPTHS OF WATER AND SEWER LINES MUST BE DETERMINED AND ANY CONFLICT WITH PROPOSED GRADES MUST BE BROUGHT TO THE ATTENTION OF THE ENGINEER FOR CORRECTION.
4. REMOVE AND STORE PARK BENCHES AND PAVILION STANDS FOR RE-USE.
5. REFER TO SHEET LD-101 FOR TREE REMOVALS.

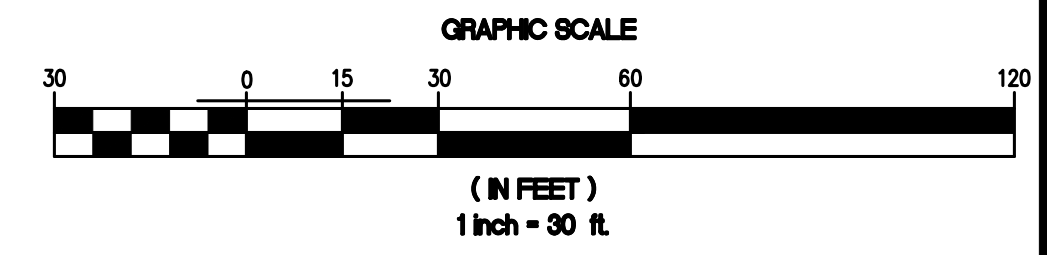
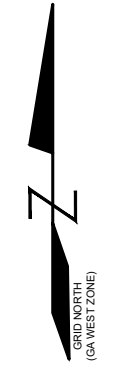

GRANITE OUTCROPPING LIMITS ARE APPROXIMATE AND NOT BASED ON SURVEY DATA. CONTRACTOR SHALL VERIFY LIMITS IN THE FIELD

PRIOR TO DIGGING VERIFY LOCATION OF EXISTING UTILITIES AND CONTACT GEORGIA 811 <https://www.georgia811.com/>

CLIENT:  

 City of Stonecrest  
 3120 Stonecrest Blvd  
 Stonecrest, GA 30038  
 770-224-0200

REVISIONS		
NO.	DATE	DESCRIPTION

C · E · R · M

1990 Lakeside Parkway  
 Suite 300  
 Tucker, GA, 30084  
 O: 678.999.0173  
 F: 678.999.0186  
[www.cerm.com](http://www.cerm.com)

PROJECT:  
 PANOLA SHOALS RIVERBANK STABILIZATION AND RESTORATION PROJECT  
 TAX ID: 16 016 03 002  
 LAND LOT 17 16th DISTRICT  
 CITY OF STONECREST  
 DEKALB COUNTY, GEORGIA

DESIGN TEAM	
DESIGN BY	CN
DRAWN BY	JD
CHECKED BY	YM

CERM PROJECT NO. 1468A-000A  
 CLIENT PROJECT NO. 21-06210-Co018-00

**DATE**  
 JUNE 29, 2022

**SHEET TITLE**  
 CLEARING AND DEMOLITION PLAN

**SHEET No**  
 C-04-01

REVISIONS		
NO.	DATE	DESCRIPTION

DESIGN TEAM	
DESIGN BY	CN
DRAWN BY	JD
CHECKED BY	YM

CERM PROJECT NO. 1468A-000A  
 CLIENT PROJECT NO. 21-06210-Co018-00

DATE  
 JUNE 29, 2022

SHEET TITLE  
**SITE PLAN**

SHEET No  
**C-05-01**

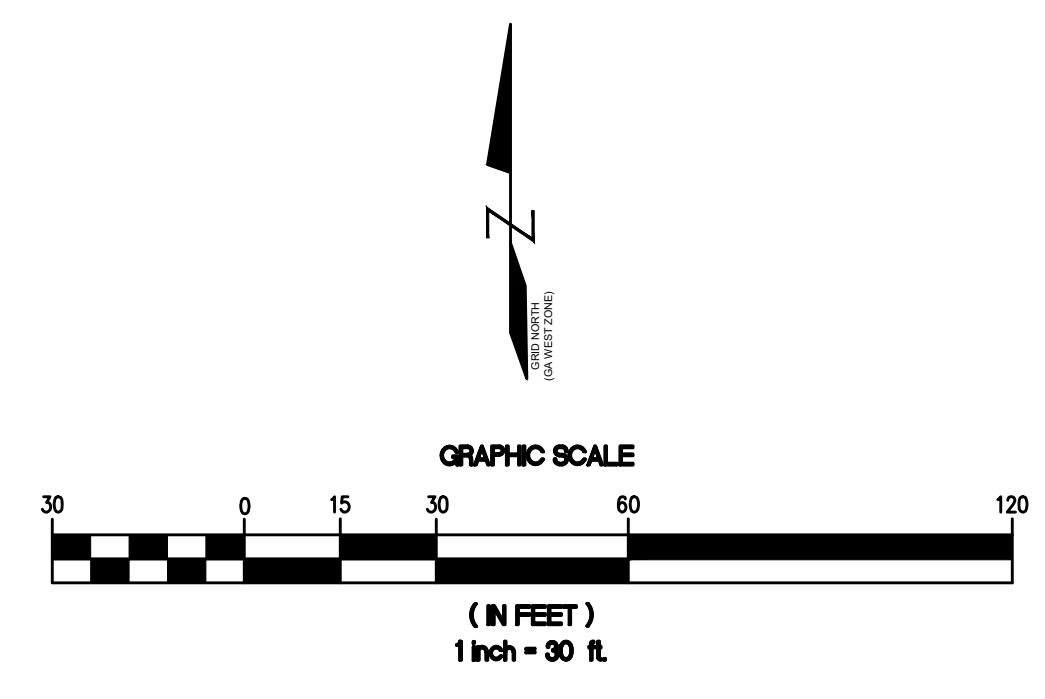

**LEGEND**

- SD — STORM SEWER
- OE — OVERHEAD ELECTRIC
- CL — CHAIN LINK FENCE
- UP — UTILITY/POWER POLE (UP)
- B — BOLLARD
- S — SIGN
- IE — INVERT ELEVATION
- CMP — CORRUGATED METAL PIPE
- x 830.5 — SPOT ELEVATION
- T — TREES
- HWD — HARDWOOD
- HW — HEADWALL (HW)
- M — MINOR CONTOUR
- MA — MAJOR CONTOUR
- [Pattern] — EXISTING ASPHALT
- [Pattern] — EXISTING CONCRETE
- [Pattern] — CONCRETE
- [Pattern] — READY-ROCK RETAINING WALL
- [Pattern] — TERRACE STONE BOLDER WALLS
- [Pattern] — PROPOSED CONCRETE
- [Pattern] — PROPOSED GRASS AREA
- [Pattern] — PROPOSED BRICK STEPS
- [Dashed] — LIMIT OF DISTURBANCE
- [Dashed] — PROPOSED PEDESTRIAN TRAIL
- [Dashed] — PROPOSED FENCE
- [Pattern] — CONTRACTOR'S LAYDOWN AREA
- [Symbol] — CONTRACTOR'S SECURE GATE
- [Dashed] — PROJECT LIMIT

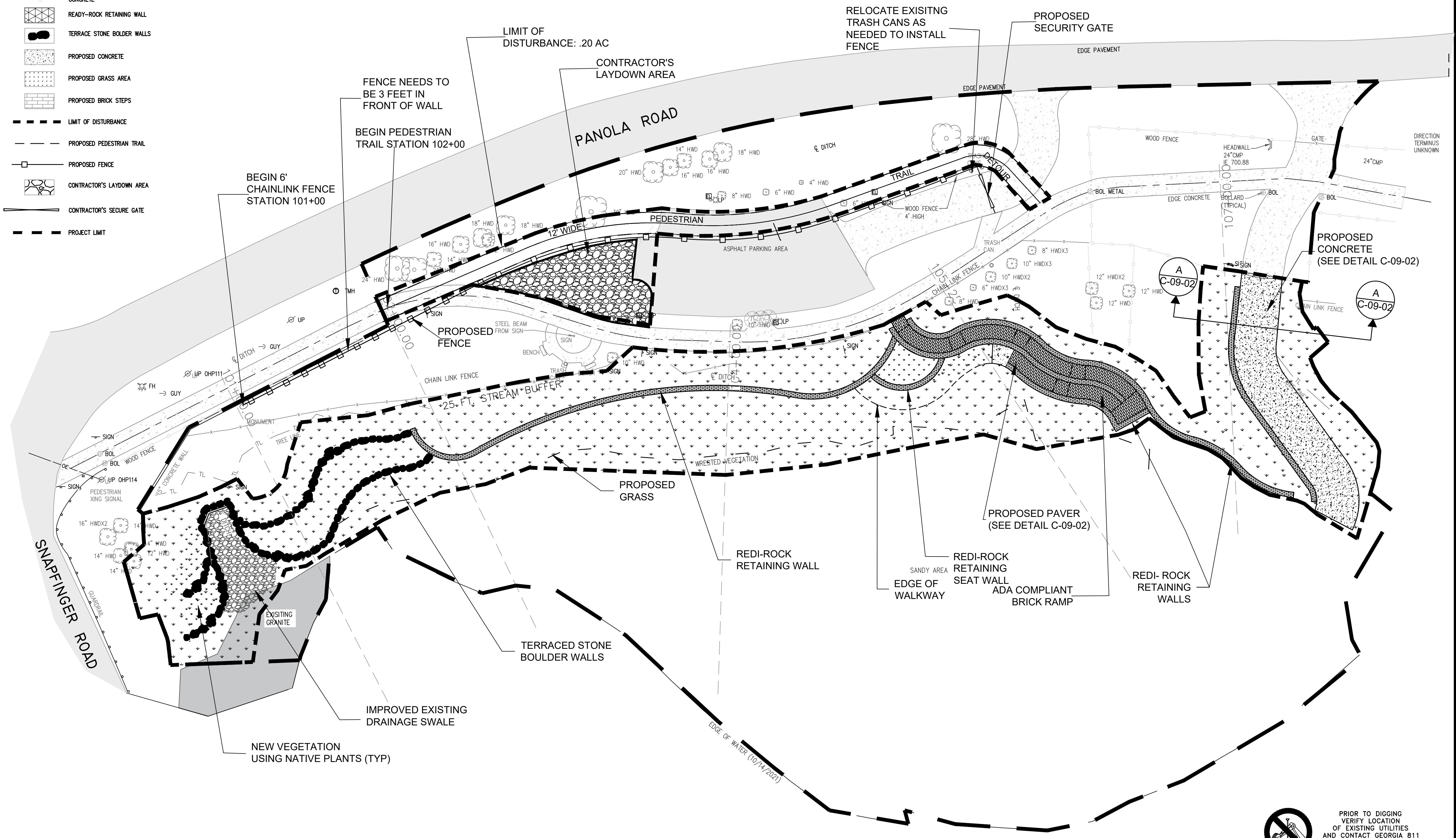

G:\Project Operations\Projects\Active Projects\2021-1468A-000A City of Stonecrest South River Stream Bank Restoration\40 - Design Documents\02 Plans\C-05 Site plan.dwg Jul 06, 2022 - 10:45pm

PRIOR TO DIGGING  
 VERIFY LOCATION  
 OF EXISTING UTILITIES  
 AND CONTACT GEORGIA 811  
<https://www.georgia811.com/>

NOTE:  
1. PLEASE SEE C-05-03 FOR CURVE GEOMETRY

- LEGEND**
- SD STORM SEWER
  - OE OVERHEAD ELECTRIC
  - CL CHAIN LINK FENCE
  - UP UTILITY/POWER POLE (UP)
  - BOLLARD
  - SIGN
  - IE INVERT ELEVATION
  - CMP CORRUGATED METAL PIPE
  - SPOT ELEVATION
  - TREES
  - HWD HARDWOOD
  - HEADWALL (HW)
  - PROPOSED PEDESTRIAN TRAIL
  - CONTRACTOR'S SECURE TRAIL
  - PROJECT LIMITS

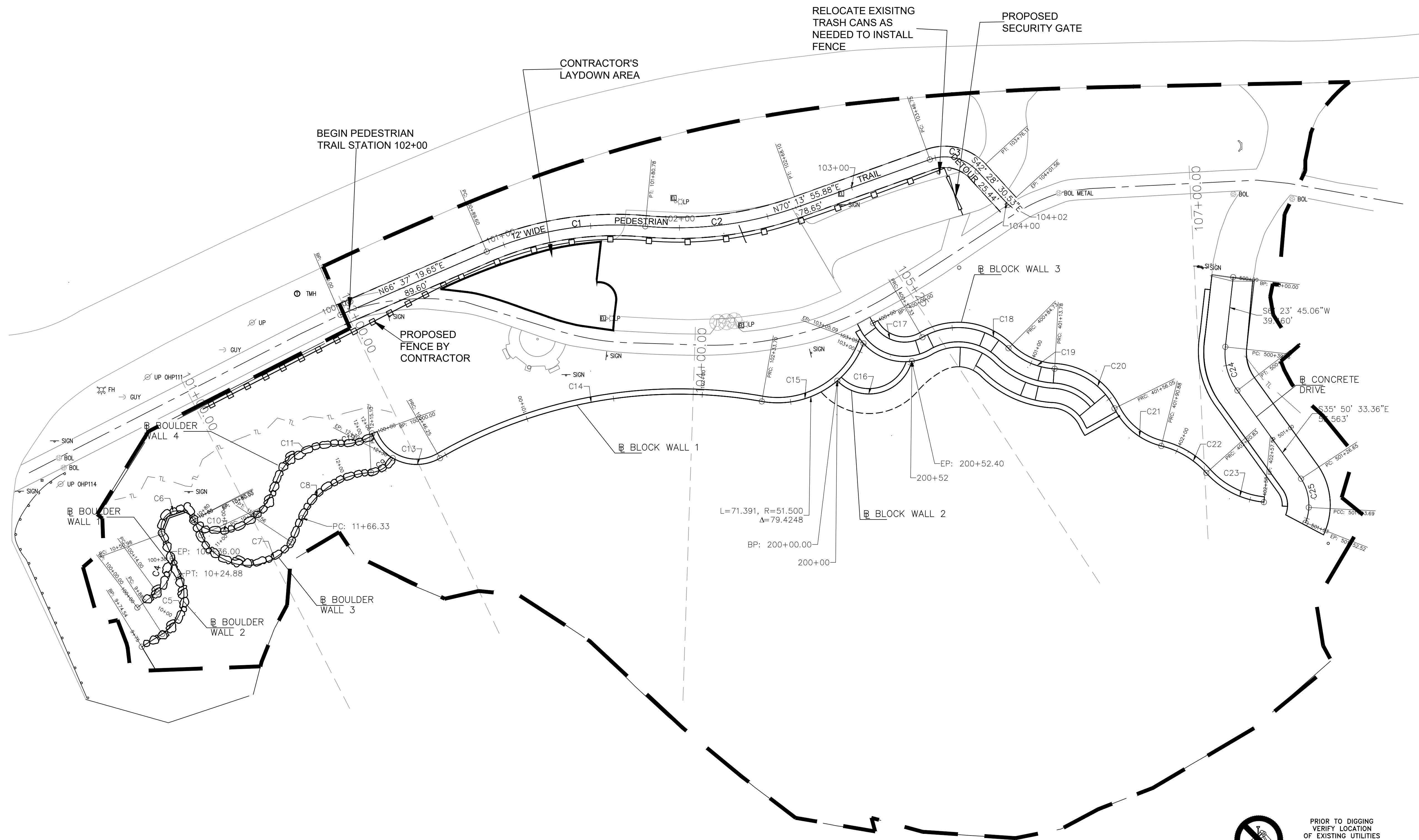
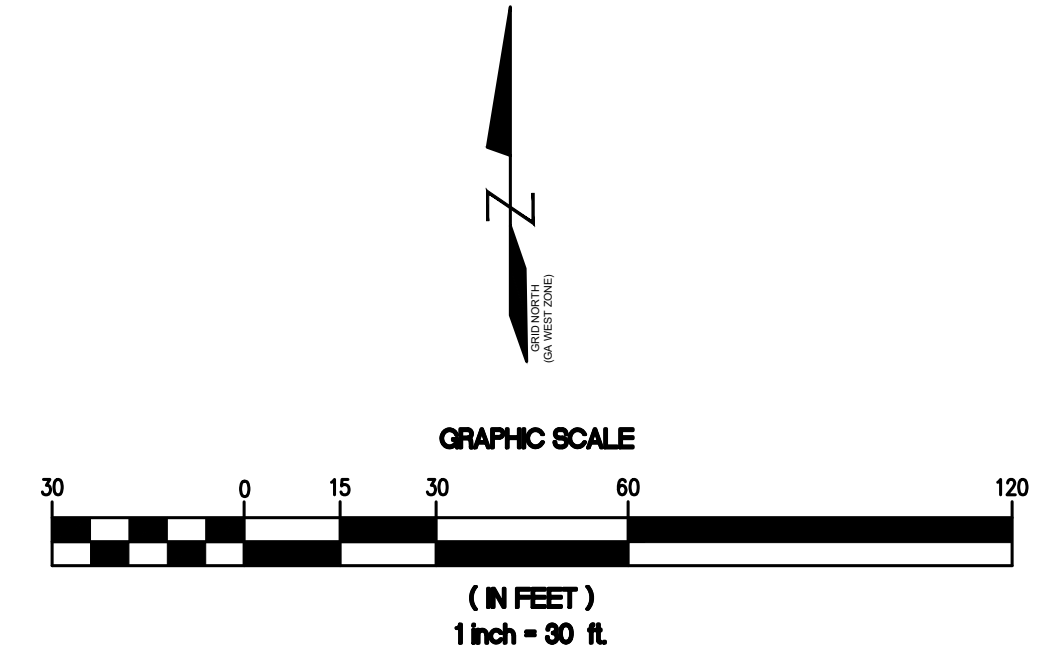

CLIENT:  
**STONECREST**  
City of Stonecrest  
3120 Stonecrest Blvd  
Stonecrest, GA 30038  
770-224-0200

REVISIONS		
NO.	DATE	DESCRIPTION

**CERM**  
1990 Lakeside Parkway  
Suite 300  
Tucker, GA, 30084  
O: 678.999.0173  
F: 678.999.0186  
[www.cerm.com](http://www.cerm.com)

PROJECT:  
PANOLA SHOALS RIVERBANK STABILIZATION  
AND RESTORATION PROJECT  
TAX ID: 16 016 03 002  
LAND LOT 17 16th DISTRICT  
CITY OF STONECREST  
DEKALB COUNTY, GEORGIA

DESIGN TEAM	
DESIGN BY	CN
DRAWN BY	JD
CHECKED BY	YM

CERM PROJECT NO. 1468A-000A  
CLIENT PROJECT NO. 21-06210-Co018-00

DATE  
JUNE 29, 2022  
SHEET TITLE

**SURVEY CONTROL PLAN**

SHEET No  
**C-05-02**

PRIOR TO DIGGING  
VERIFY LOCATION  
OF EXISTING UTILITIES  
AND CONTACT GEORGIA 811  
<https://www.georgia811.com/>

G:\Project Operations\Projects\Active Projects\2021-1468A-000A City of Stonecrest South River Stream Bank Restoration\40 - Design Documents\02 Plans\C-05 Site plan.dwg Jul 06, 2022 - 5:27pm

C:\Project\_Operations\Projects\Active Projects\2021-1468A-000A City of Stonecrest South River Stream Bank Restoration\40 - Design Documents\02 Plans\C-05 Site plan.dwg, Jul 06, 2022 - 5:27pm

Curve Table: PEDESTRIAN TRAIL								
Curve #	PC	PI	PT	Radius	Length	Chord Direction	Start Point	End Point
C1	100+ 89.60	101+ 87.88	101+ 80.78	182.51	91.18	N80° 56' 03.86"E	(2290385.82,1329299.36)	(2290474.92,1329313.57)
C2	101+ 80.78	102+ 86.10	102+ 86.10	200.00	87.32	N82° 44' 21.97"E	(2290474.92,13293163.57)	(2290560.85,1329324.52)
C3	103+ 46.75	103+ 76.11	103+ 76.11	25.00	29.36	S76° 07' 17.32"E	(2290634.87,1329351.12)	(2290661.77,1329344.48)

Curve Table: BOULDER/BLOCK WALLS								
Curve #	PC	PI	PT	Radius	Length	Chord Direction	Start Point	End Point
C4	10+ 14.00	10+ 36.00	10+ 36.00	21.52	22.00	N24° 34' 35.47"E	(2290200.47,1329107.80)	(2290209.23,1329126.95)
C5	9+ 88.11	10+ 24.88	10+ 24.88	26.61	36.77	N17° 31' 09.45"E	(2290203.42,1329084.39)	(2290213.63,1329116.74)
C6	10+ 50.98	10+ 80.03	10+ 80.03	9.64	29.05	N65° 58' 47.24"E	(2290203.31,1329140.71)	(2290220.87,1329148.54)
C7	10+ 89.66	11+ 51.56	11+ 51.56	29.14	61.90	S85° 38' 42.46"E	(2290225.23,1329139.92)	(2290275.99,1329136.05)
C8	11+ 66.33	12+ 15.13	12+ 30.42	45.36	48.80	N56° 35' 31.72"E	(2290281.96,1329149.56)	(2290320.76,1329175.15)
C9	12+ 15.13	12+ 30.42	12+ 30.42	15.08	15.29	N56° 08' 51.34"E	(2290320.76,1329175.15)	(2290332.92,1329183.31)
C10	10+ 03.05	11+ 33.44	11+ 33.44	21.67	23.05	S74° 44' 47.83"E	(2290220.87,1329148.54)	(2290242.08,1329142.76)
C11	11+ 44.11	11+ 82.81	11+ 82.81	30.26	38.70	N58° 16' 04.26"E	(2290268.43,1329172.04)	(2290299.15,1329191.04)
C12	11+ 82.81	12+ 06.19	12+ 06.19	38.51	23.38	N77° 39' 03.30"E	(2290299.15,1329191.04)	(2290321.64,1329195.96)
C13	100+ 00.00	100+ 46.25	100+ 46.25	26.50	46.25	S70° 00' 00.00"E	(2290321.39,1329197.13)	(2290359.54,1329183.24)
C14	100+ 46.25	102+ 33.70	102+ 33.70	268.50	187.45	N80° 00' 00.00"E	(2290359.54,1329183.24)	(2290540.42,1329215.13)
C15	102+ 33.70	103+ 05.09	103+ 05.09	51.50	71.39	N60° 17' 15.43"E	(2290540.42,1329215.13)	(2290597.58,1329247.75)
C16	200+ 00.00	200+ 52.40	200+ 52.40	25.00	52.40	N75° 18' 24.49"E	(2290582.88,1329226.75)	(2290624.78,1329237.74)
C17	100+ 00.00	400+ 32.33	400+ 32.33	20.00	32.33	S73° 56' 57.84"E	(2290602.93,1329259.18)	(2290630.72,1329251.19)
C18	400+ 32.33	400+ 83.73	400+ 83.73	40.00	52.40	S82° 43' 59.97"E	(2290630.72,1329251.19)	(2290679.06,1329245.02)
C19	400+ 83.73	401+ 13.78	401+ 13.78	40.00	29.05	S66° 00' 41.83"E	(2290679.06,1329245.02)	(2290705.03,1329233.47)
C20	401+ 13.78	401+ 56.05	401+ 56.05	40.00	42.26	S56° 32' 57.28"E	(2290705.03,1329233.47)	(2290738.67,1329211.24)
C21	401+ 56.05	401+ 90.88	401+ 90.88	40.00	34.83	S51° 13' 31.40"E	(2290738.67,1329211.24)	(2290764.98,1329190.11)
C22	401+ 90.88	402+ 20.83	402+ 20.83	50.00	29.95	S59° 00' 31.73"E	(2290764.98,1329190.11)	(2290790.27,1329174.92)
C23	402+ 20.83	402+ 57.98	402+ 57.98	50.00	37.16	S63° 08' 11.11"E	(2290790.27,1329174.92)	(2290822.66,1329158.51)
C24	500+ 39.46	500+ 65.57	500+ 65.57	34.19	26.11	S15° 28' 55.97"E	(2290800.98,1329245.80)	(2290807.79,1329221.24)
C25	501+ 26.65	501+ 52.52	501+ 43.69	27.00	17.03	S15° 09' 26.22"E	(2290843.53,1329171.71)	(2290847.91,1329155.54)

 PRIOR TO DIGGING  
 VERIFY LOCATION  
 OF EXISTING UTILITIES  
 AND CONTACT GEORGIA 811  
<https://www.georgia811.com/>

CLIENT:  
  
 City of Stonecrest  
 3120 Stonecrest Blvd  
 Stonecrest, GA 30038  
 770-224-0200

REVISIONS		
NO.	DATE	DESCRIPTION

  
**C · E · R · M**  
 1990 Lakeside Parkway  
 Suite 300  
 Tucker, GA, 30084  
 O: 678.999.0173  
 F: 678.999.0186  
[www.cerm.com](http://www.cerm.com)

PROJECT:  
 PANOLA SHOALS RIVERBANK STABILIZATION  
 AND RESTORATION PROJECT  
 TAX ID: 16 016 03 002  
 LAND LOT 17 16th DISTRICT  
 CITY OF STONECREST  
 DEKALB COUNTY, GEORGIA

DESIGN TEAM	
DESIGN BY	CN
DRAWN BY	JD
CHECKED BY	YM

CERM PROJECT NO. 1468A-000A  
 CLIENT PROJECT NO. 21-06210-Co018-00

DATE  
 JUNE 29, 2022

SHEET TITLE  
**SURVEY CONTROL  
 PLAN  
 CURVE TABLES**

SHEET No  
**C-05-03**



CLIENT:



City of Stonecrest  
3120 Stonecrest Blvd  
Stonecrest, GA 30038  
770-224-0200

REVISIONS

NO.	DATE	DESCRIPTION



CERM

1990 Lakeside Parkway  
Suite 300  
Tucker, GA, 30084  
O: 678.999.0173  
F: 678.999.0186  
[www.cerm.com](http://www.cerm.com)

PANOLA SHOALS RIVERBANK STABILIZATION  
AND RESTORATION PROJECT  
TAX ID: 16 016 03 002  
LAND LOT 17 16th DISTRICT  
CITY OF STONECREST  
DEKALB COUNTY, GEORGIA

PROJECT:

DESIGN TEAM

DESIGN BY	CN
DRAWN BY	JD
CHECKED BY	YM

CERM PROJECT NO. 1468A-000A  
CLIENT PROJECT NO. 21-06210-Co018-00

DATE

JUNE 29, 2022

SHEET TITLE

GRADING PLAN

SHEET No

C-06-01

**LEGEND**

- EXISTING CONTOUR
- PROPOSED CONTOUR
- PROPOSED STORM DRAINAGE SYSTEM
- EXISTING STORM DRAINAGE SYSTEM
- DRAINAGE INLET
- GRADING LIMITS
- PROJECT LIMITS
- TW TOP OF WALL
- BW BOTTOM OF WALL
- X 693.28 SPOT ELEVATIONS
- PROPOSED FENCE
- CONTRACTOR'S LAYDOWN AREA
- CONTRACTOR'S SECURE GATE
- LIMIT OF DISTURBANCE
- PROJECT LIMIT

GRAPHIC SCALE  
(IN FEET)  
1 inch = 30 ft.

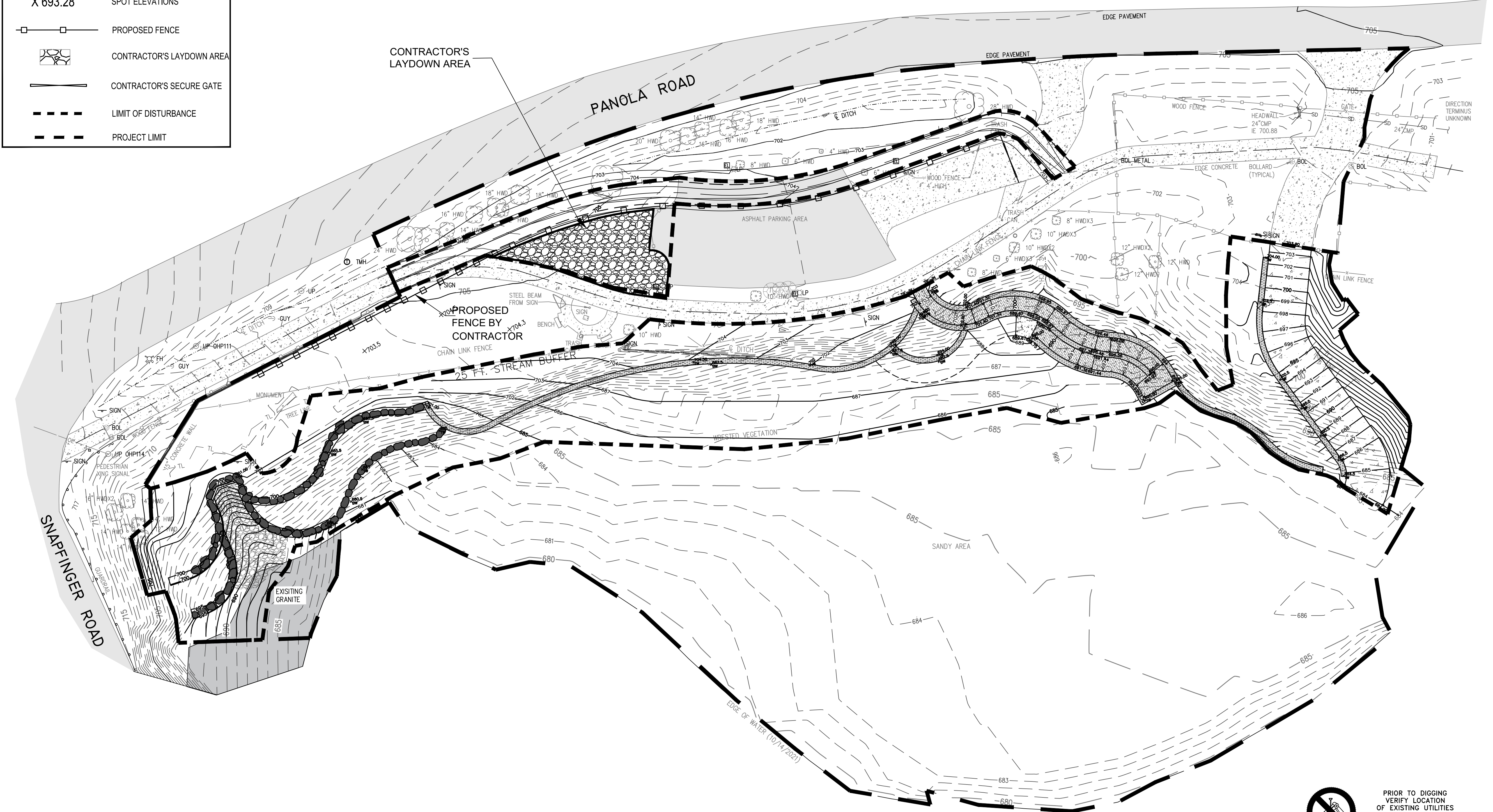

C:\Project\_Operations\Projects\Active Projects\2021-1468A-000A\_City of Stonecrest South River Stream Bank Restoration\40 - Design Documents\02 Plans\C-06 Grading Plan.dwg Jul 06, 2022 - 5:27pm

PRIOR TO DIGGING  
VERIFY LOCATION  
OF EXISTING UTILITIES  
AND CONTACT GEORGIA 811  
<https://www.georgia811.com/>

C:\Project Operations\Projects\Active Projects\2021-1468A-000A City of Stonecrest South River Stream Bank Restoration\40 - Design Documents\02 Plans\C-06 Wall Envelopes and Profiles.dwg Jul 06, 2022 - 5:27pm

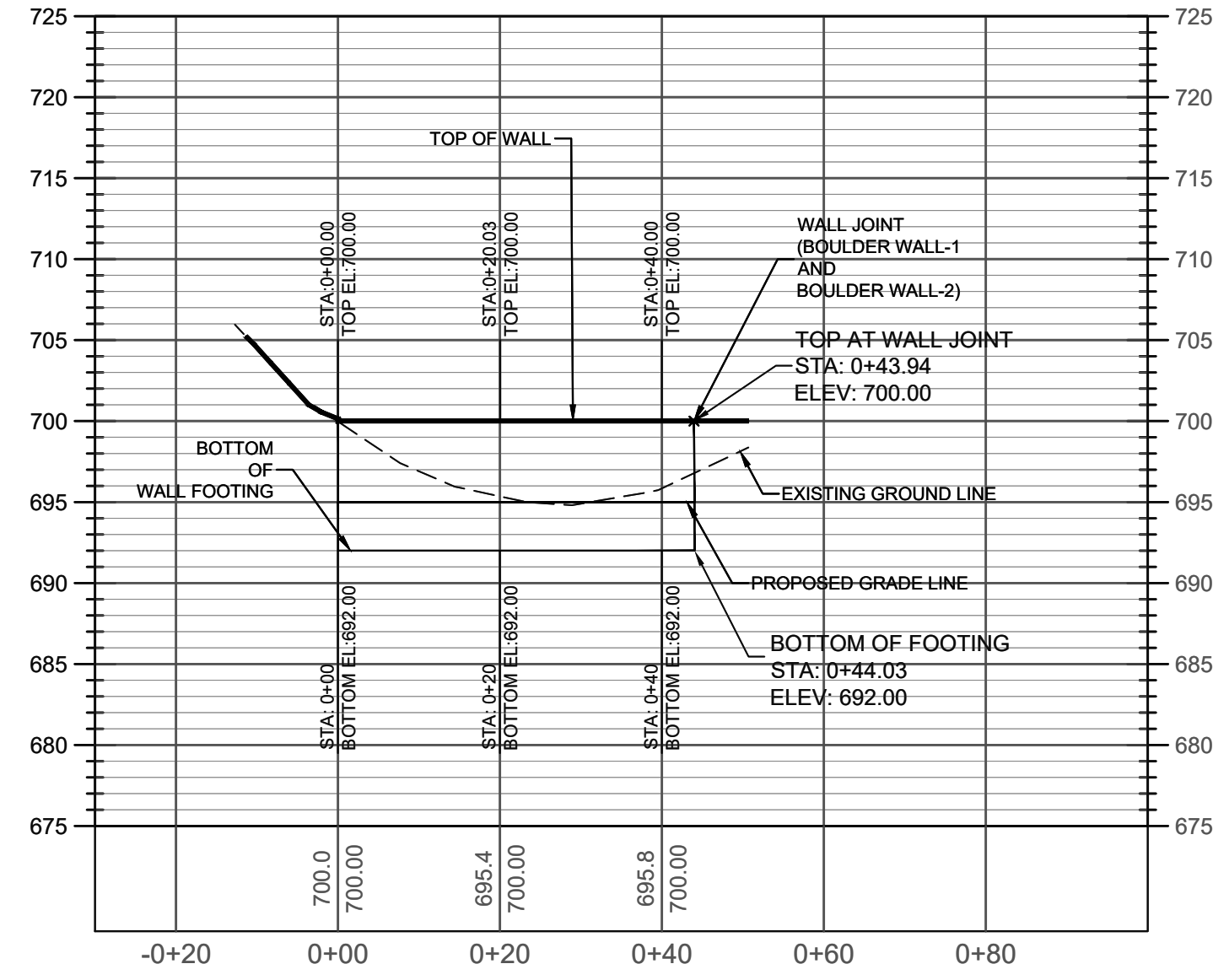

**PROFILE VIEW**  
BOULDER WALL-2  
1" = 20' HORZ.  
1" = 10' VERT.

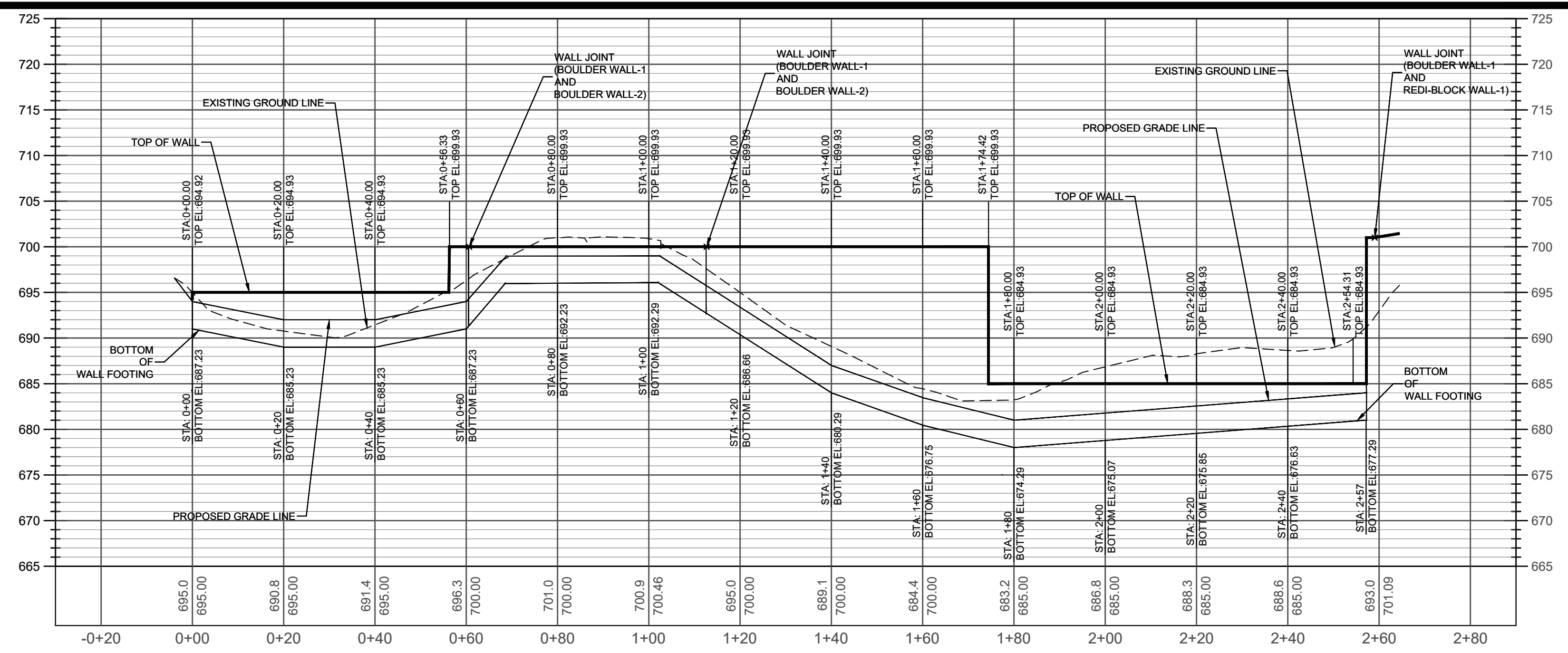

**PROFILE VIEW**  
BOULDER WALL-1  
1" = 20' HORZ.  
1" = 10' VERT.

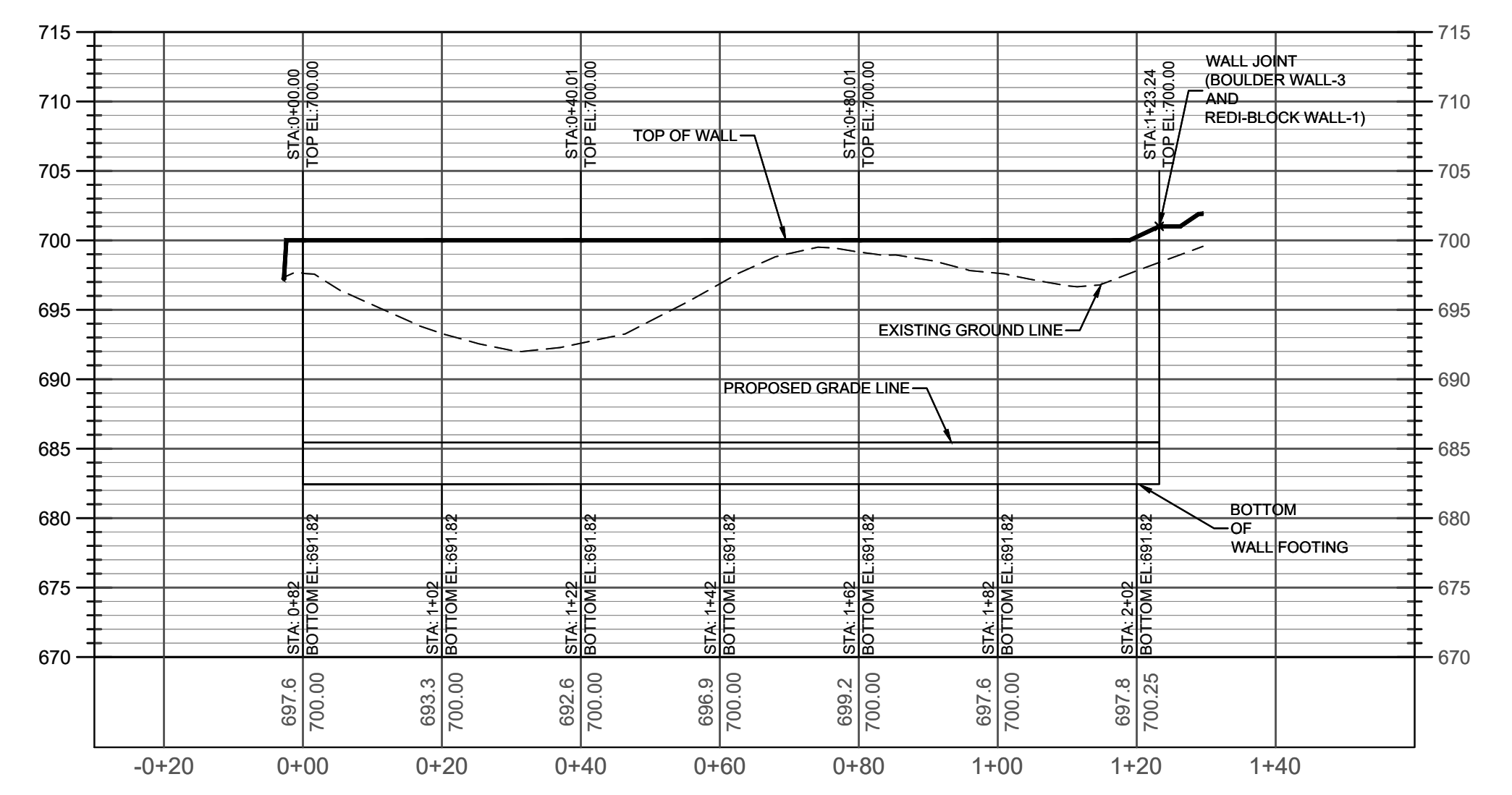
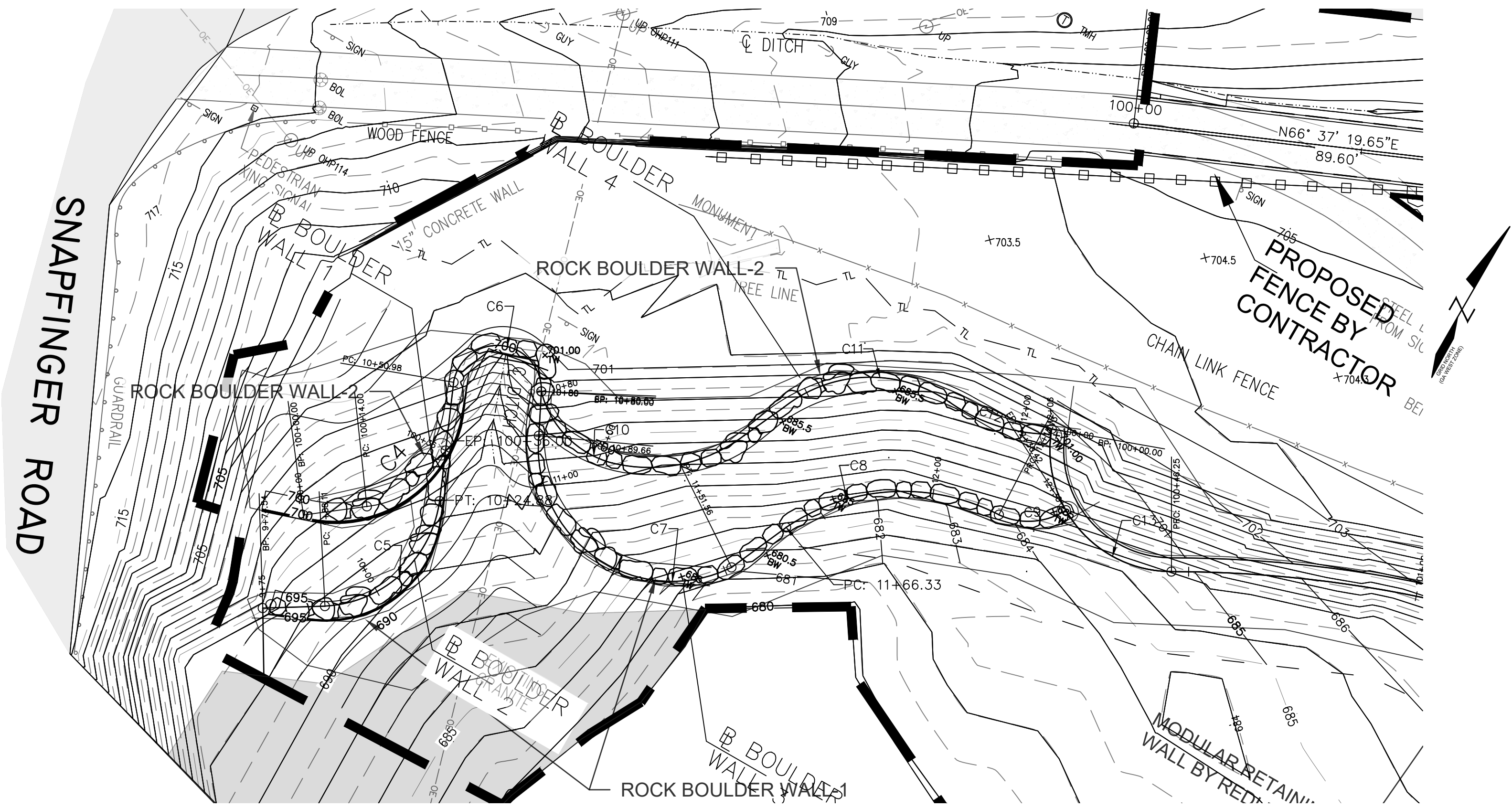

**PROFILE VIEW**  
BOULDER WALL-3  
1" = 20' HORZ.  
1" = 10' VERT.

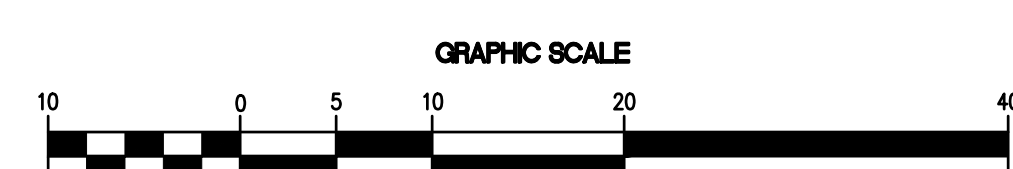
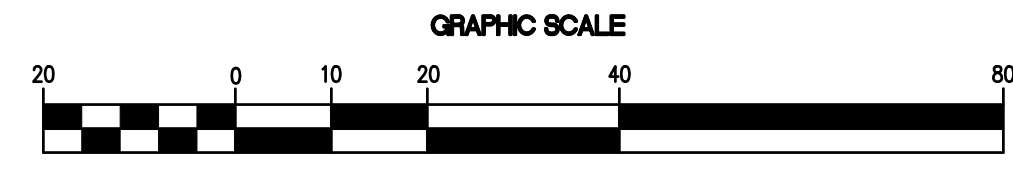

PRIOR TO DIGGING  
VERIFY LOCATION  
OF EXISTING UTILITIES  
AND CONTACT GEORGIA 811  
<https://www.georgia811.com/>

CLIENT:  
  
City of Stonecrest  
3120 Stonecrest Blvd  
Stonecrest, GA 30038  
770-224-0200

REVISIONS		
NO.	DATE	DESCRIPTION

1990 Lakeside Parkway  
Suite 300  
Tucker, GA, 30084  
O: 678.999.0173  
F: 678.999.0186  
[www.cerm.com](http://www.cerm.com)

PROJECT:  
PANOLA SHOALS RIVERBANK STABILIZATION  
AND RESTORATION PROJECT  
TAX ID: 16 016 03 002  
LAND LOT 17 16th DISTRICT  
CITY OF STONECREST  
DEKALB COUNTY, GEORGIA

DESIGN TEAM  
DESIGN BY: CN  
DRAWN BY: JD  
CHECKED BY: YM  
CERM PROJECT NO. 1468A-000A  
CLIENT PROJECT NO. 21-06210-Co018-00  
DATE: JUNE 29, 2022  
SHEET TITLE: WALL ENVELOPES AND PROFILES  
SHEET No: C-06-02

REVISIONS		
NO.	DATE	DESCRIPTION

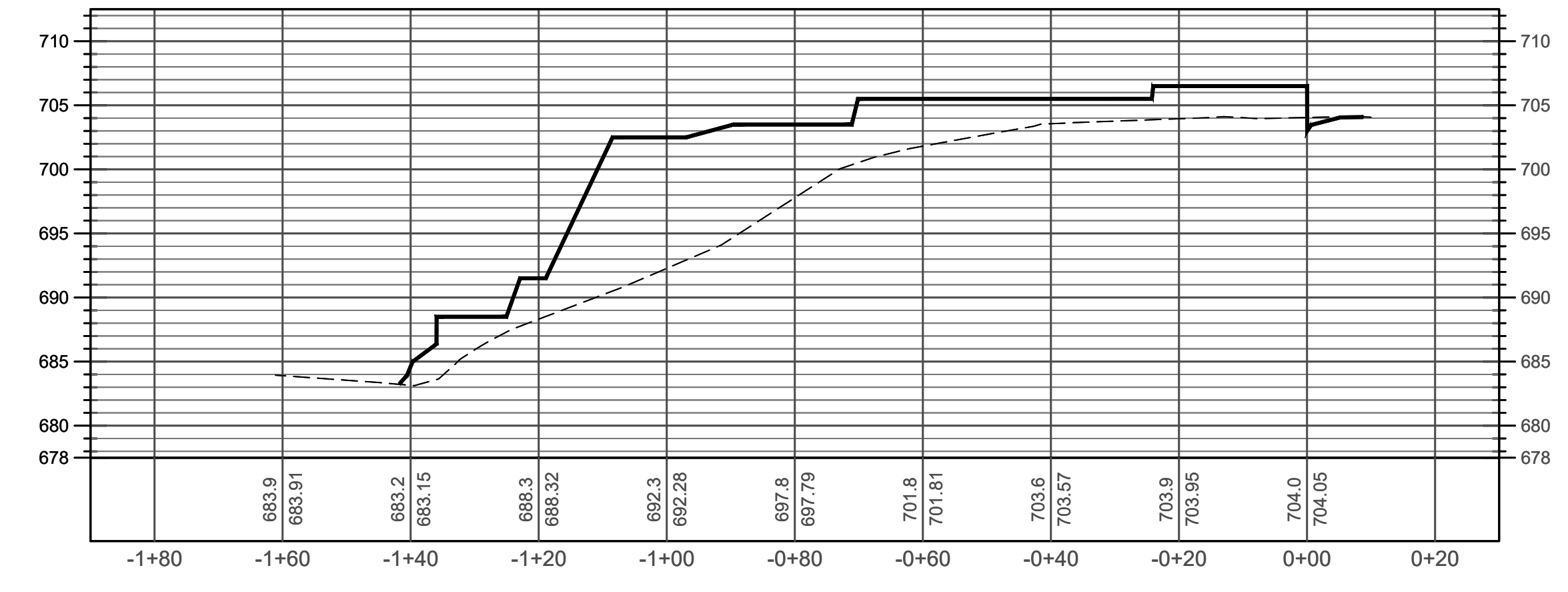
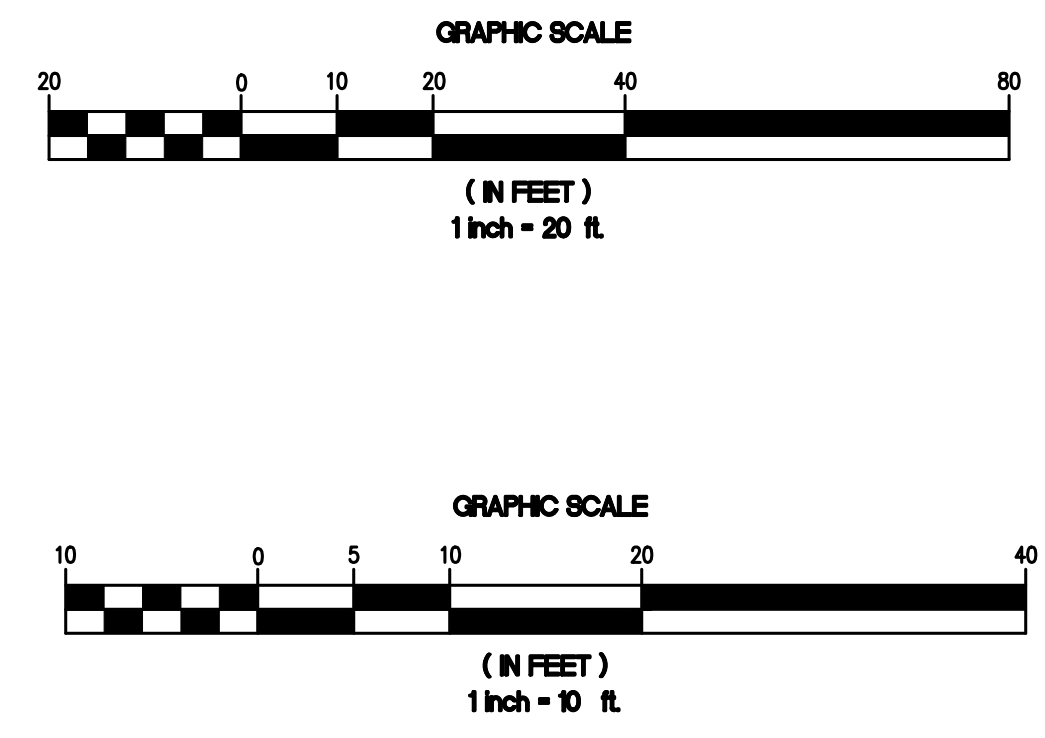
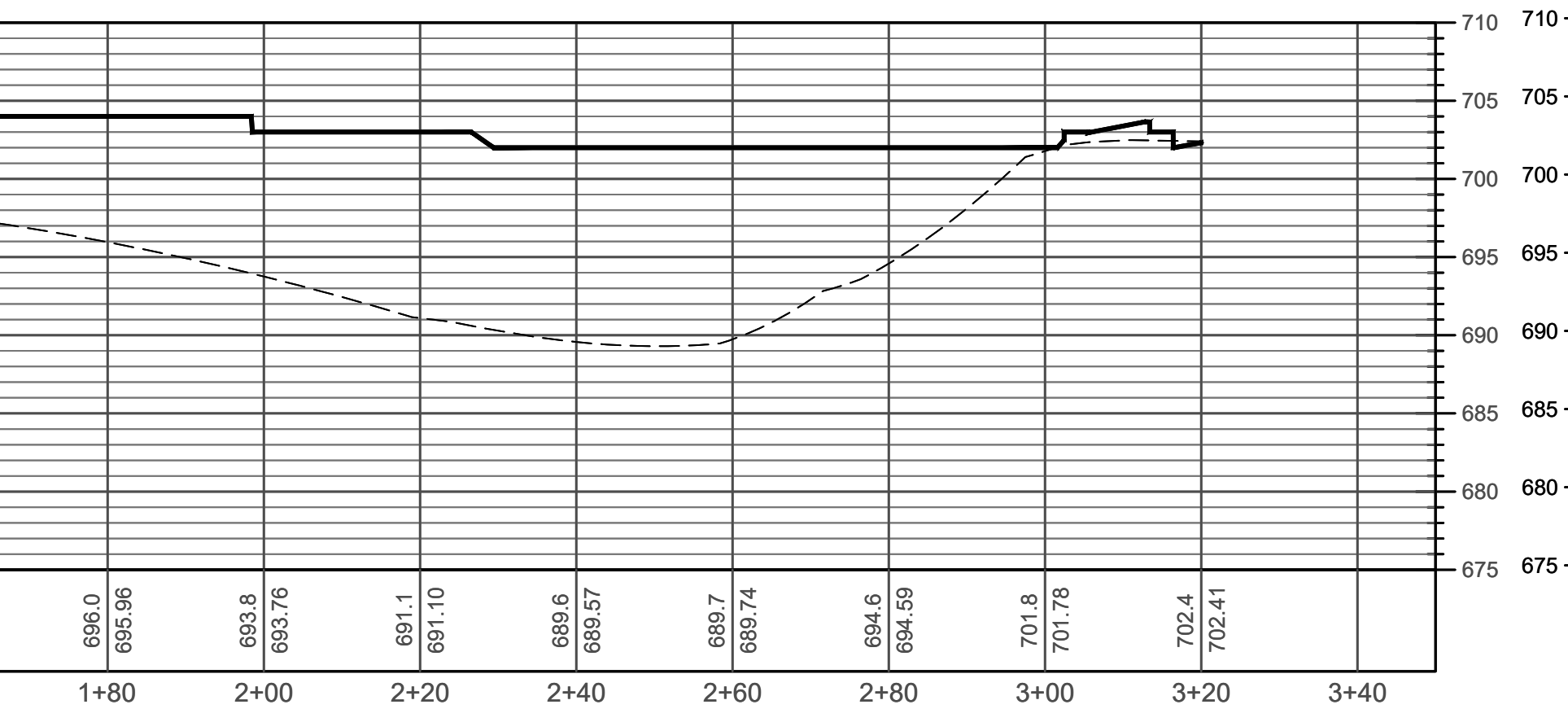
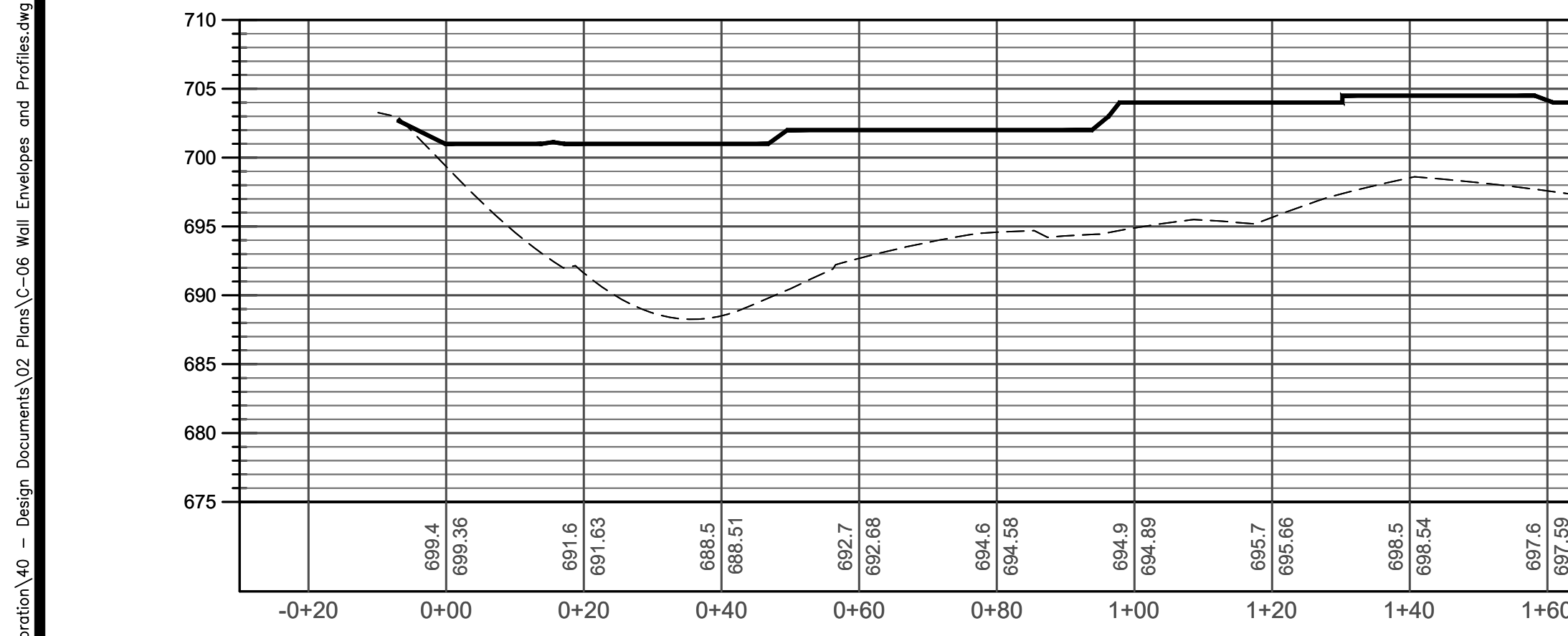
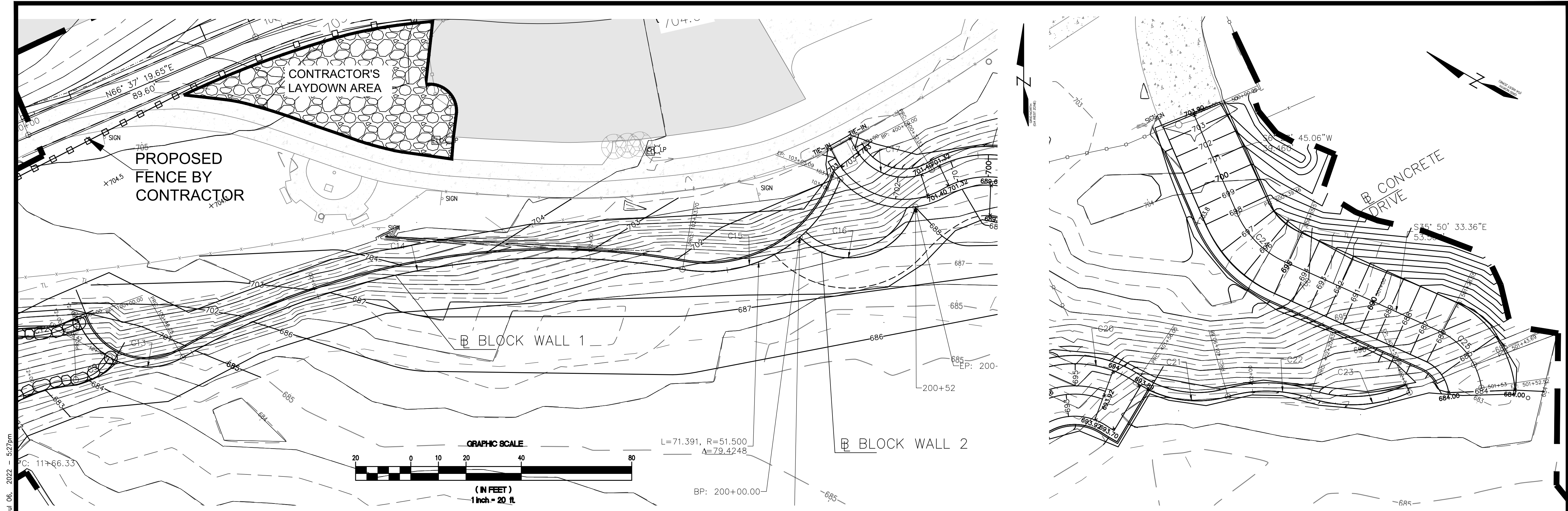

**PRIOR TO DIGGING VERIFY LOCATION OF EXISTING UTILITIES AND CONTACT GEORGIA 811**  
<https://www.georgia811.com/>

C:\Project\_Operations\Projects\Active Projects\2021-1468A-000A City of Stonecrest South River Stream Bank Restoration\0 - Design Documents\02 Plans\C-06 Wall Envelopes and Profiles.dwg Jul 06, 2022 - 5:27pm

C:\Project Operations\Projects\Active Projects\2021-1488A-000A City of Stonecrest South River Stream Bank Restoration\40 - Design Documents\02 Plans\C-06 Wall Envelopes and Profiles.dwg Jul 06, 2022 - 5:27pm

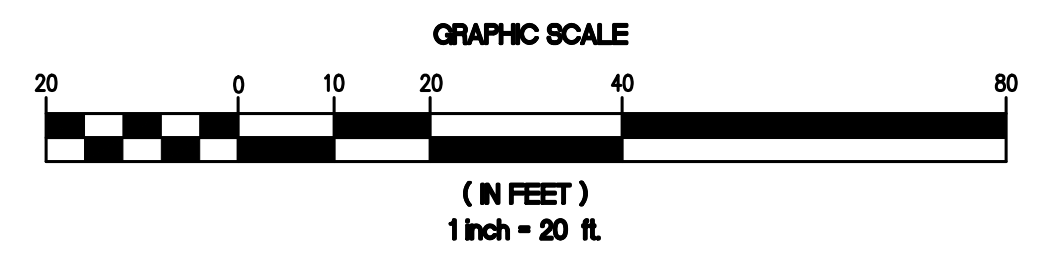
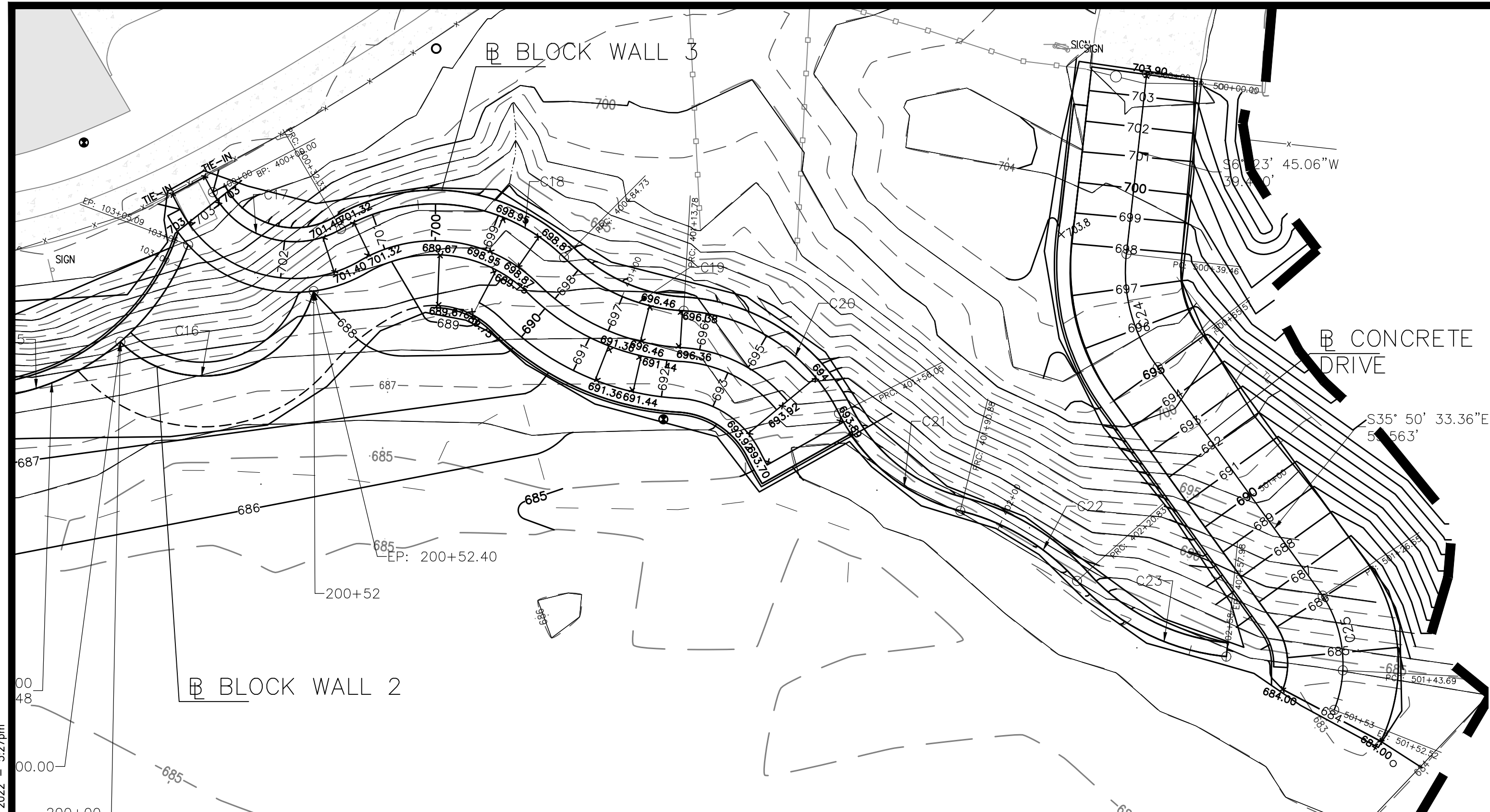

CLIENT:  
**STONECREST**  
City of Stonecrest  
3120 Stonecrest Blvd  
Stonecrest, GA 30038  
770-224-0200

REVISIONS		
NO.	DATE	DESCRIPTION

**CERM**  
1990 Lakeside Parkway  
Suite 300  
Tucker, GA, 30084  
O: 678.999.0173  
F: 678.999.0186  
[www.cerm.com](http://www.cerm.com)

PROJECT:  
PANOLA SHOALS RIVERBANK STABILIZATION  
AND RESTORATION PROJECT  
TAX ID: 16 016 03 002  
LAND LOT 17 16th DISTRICT  
CITY OF STONECREST  
DEKALB COUNTY, GEORGIA

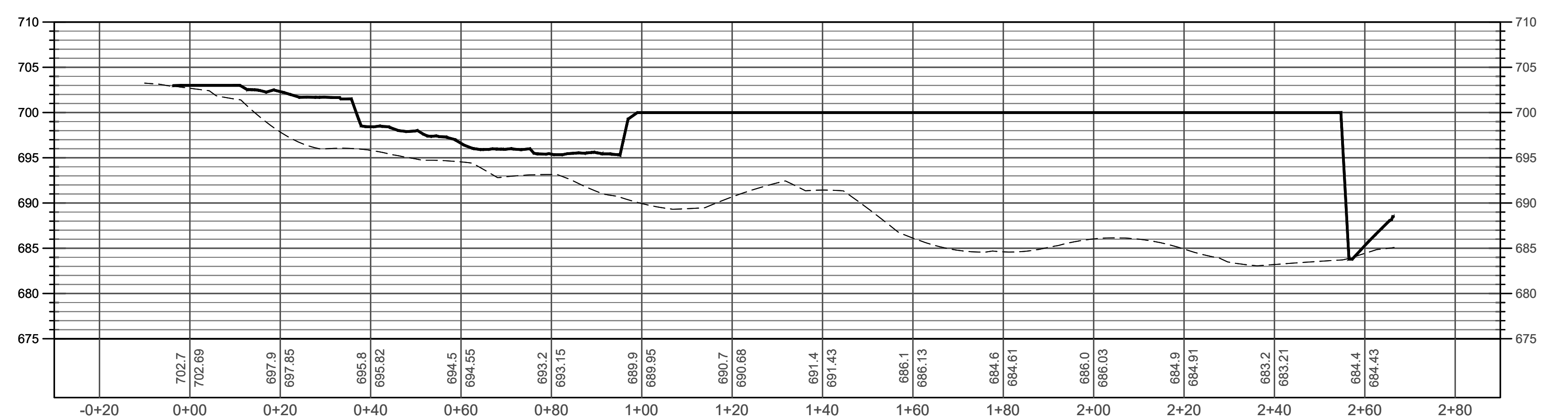
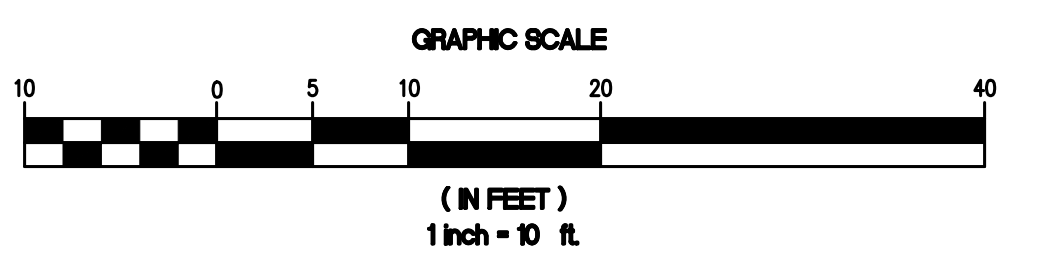
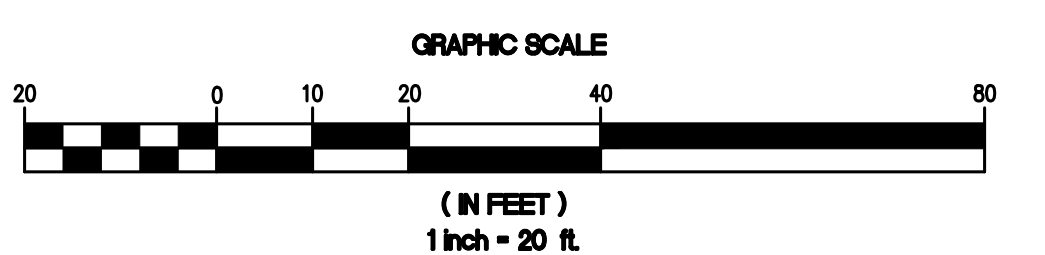
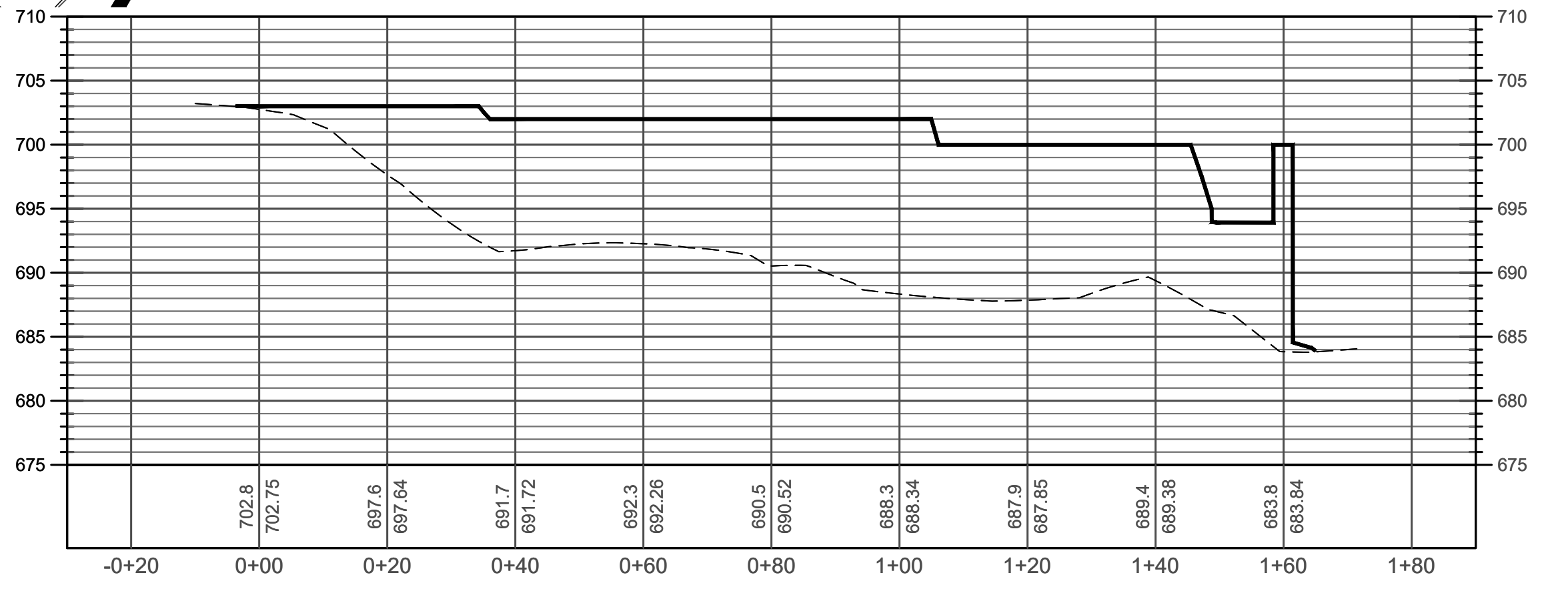
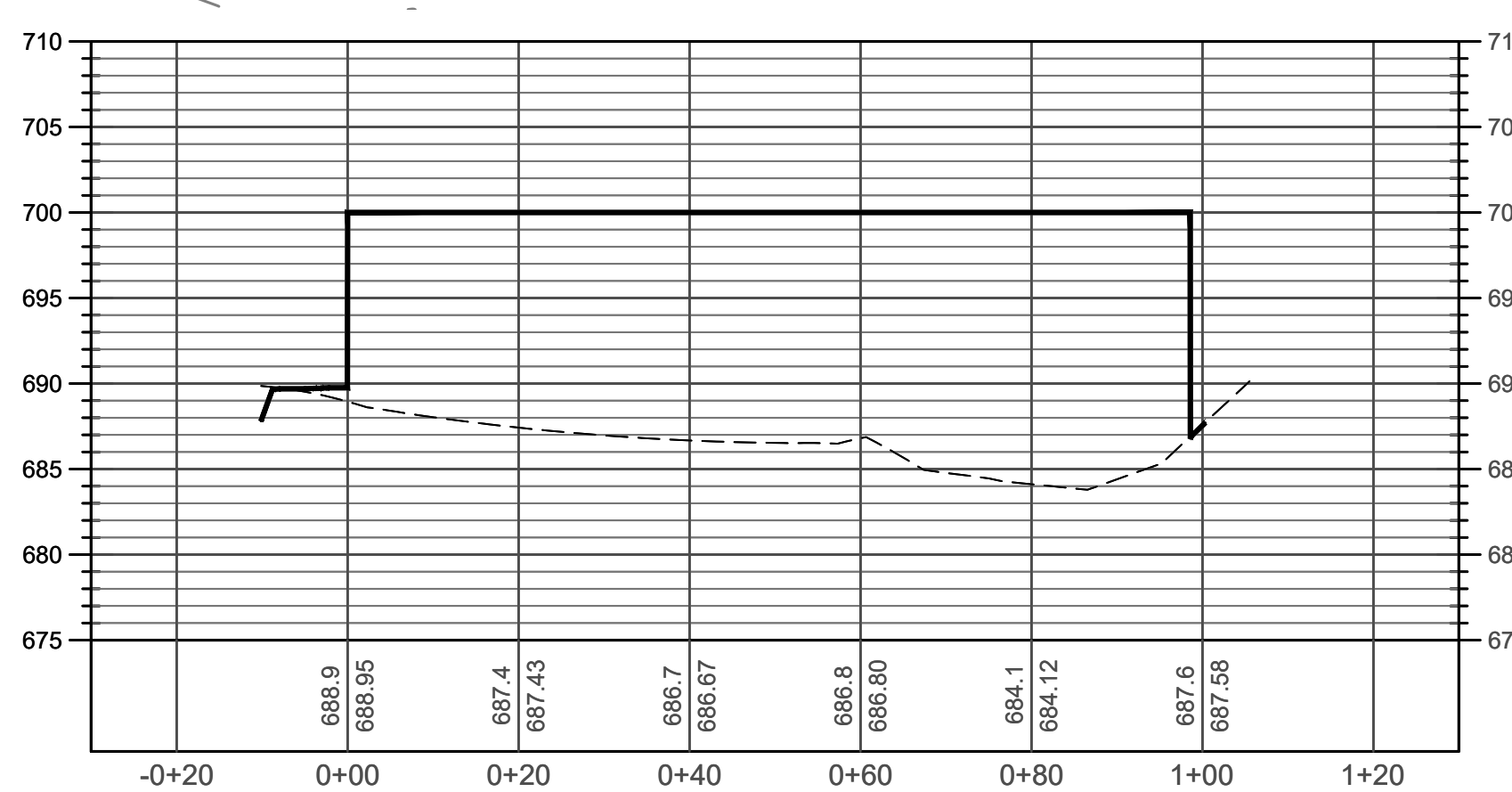

PRIOR TO DIGGING  
VERIFY LOCATION  
OF EXISTING UTILITIES  
AND CONTACT GEORGIA 811  
<https://www.georgia811.com/>

DESIGN TEAM	
DESIGN BY	CN
DRAWN BY	JD
CHECKED BY	YM
CERM PROJECT NO. 1468A-000A	
CLIENT PROJECT NO. 21-06210-Co018-00	
DATE JUNE 29, 2022	
SHEET TITLE <b>WALL ENVELOPES AND PROFILES</b>	
SHEET No <b>C-06-04</b>	

- The applicable erosion, sedimentation and pollution control plan checklist is provided on this plan.
- Level II certificate for Yasmin Moreno is provided on sheet . Cert. # 0000029509, Exp. 06/27/2024
- Limit of disturbance is 1.13 ac.
- The 24-hour local contact responsible for erosion, sedimentation and pollution controls is: Johnathan Walker, Tel: 404-546-3793
- Primary permittee is Stonecrest
- Total area = 5.26ac / Disturbed area = 1.13ac
- GPS location of the site construction exit = 33.654598N, -84.186088W
- Initial date of the plan is November 23, 2022
- Description of the nature of construction activity:
  - Installation od sediment control measures & Tree protection
  - Clearing and Grading
  - Retaining walls
  - Storm pipes and Final Grading
  - Landscaping and Irrigation
  - Project Closeout and Restoration
- Vicinity map provided on sheet C-01
- The receiving water is the South River that runs through the site close to the southern property line. There are sensitive features on or near the site that will be impacted by runoff from the site.

12. STATEMENT  
I CERTIFY UNDER PENALTY OF LAW THAT THIS PLAN WAS PREPARED AFTER A SITE VISIT TO THE LOCATIONS DESCRIBED HEREIN BY MYSELF OR MY AUTHORIZED AGENT, UNDER MY SUPERVISION.

05/19/2022  
DATE

SIGNATURE

13. STATEMENT  
I CERTIFY THAT THE PERMITTEE'S EROSION, SEDIMENTATION AND POLLUTION CONTROL PLAN PROVIDES FOR AN APPROPRIATE AND COMPREHENSIVE SYSTEM OF BEST MANAGEMENT PRACTICES REQUIRED BY THE GEORGIA WATER QUALITY CONTROL ACT AND THE DOCUMENT "MANUAL FOR EROSION AND SEDIMENT CONTROL IN GEORGIA" (MANUAL) PUBLISHED BY THE GEORGIA SOIL AND WATER CONSERVATION COMMISSION AS OF JANUARY 1 OF THE YEAR IN WHICH THE LAND-DISTURBING ACTIVITY WAS PERMITTED, PROVIDES FOR THE SAMPLING OF THE RECEIVING WATER(S) OR THE SAMPLING OF THE STORM WATER OUTFALLS AND THAT THE DESIGNED SYSTEM OF BEST MANAGEMENT PRACTICES AND SAMPLING METHODS IS EXPECTED TO MEET THE REQUIREMENTS CONTAINED IN THE GENERAL NPDES PERMIT NO. GAR 100001.

05/19/2022  
DATE

SIGNATURE

14. The design professional who prepared the ES&PC Plan is to inspect the installation of the initial sediment storage requirements and perimeter control BMPs within 7 days after installation.

DESIGN PROFESSIONAL 7-DAY VISIT CERTIFICATION

DATE OF INSPECTION \_\_\_\_\_

I CERTIFY THE SITE WAS IN COMPLIANCE WITH THE ES&PC PLAN ON THE DATE OF INSPECTION

CSWCC LEVEL II DESIGN PROFESSIONAL CERTIFICATION # \_\_\_\_\_

INSPECTION REVEALED THE FOLLOWING DISCREPANCIES FROM THE ES&PC PLAN.

\_\_\_\_\_

\_\_\_\_\_

\_\_\_\_\_

\_\_\_\_\_

\_\_\_\_\_

THESE DEFICIENCIES MUST BE ADDRESSED IMMEDIATELY AND A RE-INSPECTION SCHEDULED. WORK SHALL NOT PROCEED ON THE SITE UNTIL DESIGN PROFESSIONAL CERTIFICATION IS OBTAINED.

- Non-exempt activities shall not be conducted within the 25 or 50-foot undisturbed stream buffers as measured from the point of vested vegetation or within 25-feet of the coastal marshland buffer as measured from the Jurisdictional Determination Line without first acquiring the necessary variances and permits.
- There is no buffer encroachment from the proposed activities and no buffer variance is required.
- Amendments/revisions to the ES&PC Plan which have a significant effect on BMPs with a hydraulic component must be certified by the design professional.
- Waste materials shall not be discharged to waters of the State, except as authorized by a Section 404 permit.
- The escape of sediment from the site shall be prevented by the installation of erosion and sediment control measures and practices prior to land disturbing activities.
- Erosion control measures will be maintained at all times. If full implementation of the approved Plan does not provide for effective erosion control, additional erosion and sediment control measures shall be implemented to control or treat the sediment source.
- Any disturbed area left exposed for a period greater than 14 days shall be stabilized with mulch or temporary seeding.
- This site will not discharge storm water into an impaired stream.
- A TMDL implementation plan is note required for this site.
- ES&PC Plan indicates an area is designated for concrete washdown of tools, concrete mixer chutes, hoppers and the rear of the vehicles. Washout of the drum at the construction site is prohibited.
- Remediation of all petroleum spills and leaks:
  - Local, state and manufacturer's recommended methods for spill cleanup will be clearly posted and procedures will be made available to site personnel.
  - Material and equipment necessary for spill cleanup will be kept in the material storage areas. Typical materials and equipment include, but is not limited to, brooms, dustpans, maps, rags, gloves, goggles, cat litter, sand, sawdust and properly labeled plastic and metal waste containers.
  - Spill prevention practices and procedures will be reviewed after a spill and adjusted as necessary to prevent future spills.
  - All spills will be cleaned up immediately upon discovery. All spills will be reported as required by local, state and federal regulations.
  - For spills that impact surface water (leave a sheen on surface water), the National Response Center (NRC) will be contacted within 24 hours at 1-800-426-2675.
  - For spills of an unknown amount, the National Response Center (NRC) will be contacted within 24 hours at 1-800-426-2675.
  - For spills greater than 25 gallons and no surface water impacts, the Georgia EPD will be contacted within 24 hours.
  - For spills less than 25 gallons and no surface water impacts, the spill will be cleaned up and local agencies

will be contacted as required.

The contractor shall notify the licensed professional who prepared this plan if more than 1320 gallons of petroleum is stored onsite (this includes capacities of equipment) or if any one piece of equipment has a capacity greater than 660 gallons. The Contractor will need a Spill Prevention Containment and Countermeasures Plan prepared by that licensed professional.

- After construction is completed, several ES&PC BMPs installed during construction will continue to control pollutants in the storm water runoff from the site. Storm water runoff will flow mainly as sheet flow across the site and will pass through grassed swales and open areas, which will help to slow down the velocity and trap sediments. The water quality bioretention area will also continue to intercept and treat the initial runoff from the site.
- Plastic sheeting or temporary roofs shall be provided to cover building materials, building products, construction wastes, trash, landscape materials, fertilizers, pesticides, herbicides, detergents, sanitary waste, and other materials in order to minimize exposure to precipitation and to stormwater.
- Potential sources of pollution include site grading, from construction equipments and concrete material.

The practices that will be used to reduce the pollutants in storm water discharges include:
  - Silt fence installed along the perimeter of the site and in strategic interior areas to prevent migration of sediments from the active construction zone into non-construction zones that will continue to be use by the facility.
  - Rock check dams will be installed along the proposed swales to prevent movement of soil through the swales. They will remain in place until permanent vegetation is established.
  - Sediment traps will be installed around exposed storm inlets to prevent sediment from washing into the underground storm system.
  - All disturbed areas will be covered with permanent grassing.

29. Construction timeline:

APPROXIMATE ACTIVITY SCHEDULE  
ANTICIPATED START DATE: NOVEMBER 23, 2022  
ANTICIPATED COMPLETION DATE: JANUARY 31, 2024

	2022		2023				2024		
	A	S	O	N	D	J	F	M	A
INSTALLATION OF SEDIMENT CONTROL MEASURES & TREE PROTECTION									
CLEARING AND GRADING									
RETAINING WALLS									
STORM PIPES AND FINAL GRADING									
LANDSCAPING AND IRRIGATION									
PROJECT CLOSEOUT AND RESTORATION									

- Record keeping:
  - Each primary permittee shall retain a copy of the erosion, sedimentation and pollution control plan required by this permit at the construction site or the plan shall be readily available at a designated alternate location from the date of project initiation to the date of final stabilization. primary permittees are encouraged to post copies of their NOI, erosion, sedimentation & pollution control plan, sampling results, inspection reports, etc. on or in a permit board at the construction exit to facilitate inspections by local issuing authorities and EPD.
  - Copies of all notices of intent, notices of termination, reports, plans, monitoring reports, monitoring information, including all calibration and maintenance records and all original strip chart recordings for continuous monitoring instrumentation, erosion, sedimentation and pollution control plans, records of all data used to complete the notice of intent to be covered by this permit and all other records required by this permit shall be retained by the permittee who either produced or used it for a period of at least three years from the date that the site is finally stabilized. these records must be maintained at the permittee's primary place of business once the construction activity has ceased at the permitted site. this period may be extended by request of the EPD at any time upon written notification to the permittee.
- Sampling frequency and reporting of sampling results:

Sampling frequency:  
Stormwater samples shall be taken for the following areas:
  - For each area of the site that discharges to a receiving stream, the first rain event that reaches or exceeds 0.5 inch and allows for monitoring during normal business hours\* (Monday to Friday, 8:00 am to 5:00 pm and Saturday 8:00 am to 5:00 pm when construction activity is being conducted by the primary permittee ) that occurs after all clearing and grubbing operations have been completed in the drainage area of the location selected as the sampling location;
  - In addition to (1) above, for each area of the site that discharges to a receiving stream, the first rain event that reaches or exceeds 0.5 inch and allows for monitoring during normal business hours\* that occurs either 90 days after the first sampling event or after all mass grading operation have been completed in the drainage area of the location selected as the sampling location, whichever comes first;
  - At the time of sampling performed pursuant to (1) and (2) above, if BMPs are found to be properly designed, installed and maintained, no further action is required. if BMPs in any area of the site that discharges to a receiving stream are not properly designed, installed and maintained, corrective action shall be defined and implemented within 2 business days, and turbidity samples shall be taken from discharges from that area of the site for each subsequent rain event that reaches or exceeds 0.5 inch during normal business hours\* until the selected turbidity standard is attained, or until post storm event inspections determine that BMPs are properly designed, installed and maintained.

Note that the permittee may choose to meet the requirements of (1) and (2) above by collecting turbidity samples from any rain event that reaches or exceeds 0.5 inch and allows for monitoring at any time of day or week.

The primary permittee must sample in accordance with the plan at least once for each rainfall event described below, for a qualified event, samples must be taken within forty-five (45) minutes of:
  - The accumulation of the minimum amount of rainfall for the qualifying event, if the storm water discharge to a monitored receiving water or from a monitored outfall has begun at or prior to the accumulation, or
  - The beginning of any storm water discharge to a monitored receiving water or from a monitored outfall, if the discharge begins after the accumulation of the minimum amount of rainfall for the qualifying event.

However, where manual and automatic sampling are impossible (as defined in this permit), or are beyond the permittee's control, the permittee shall take samples as soon as possible, but in no case more than twelve (12) hours after the beginning of the storm water discharge.

Reporting of sampling results:
  - The applicable permittees are required to submit a summary of the monitoring results to EPD at the address shown in part II.c. by the fifteenth day of the month following the reporting period. reporting periods are months during which samples are taken in accordance with this permit. sampling results shall be in a clearly legible format. upon written notification, EPD may require the applicable permittee to submit the sampling results on a more frequent basis. sampling and analysis of any stormwater discharge(s) or the receiving water(s) beyond the minimum frequency stated in this permit must be reported in a similar manner to the EPD. the sampling reports must be signed in accordance with part V.g. sampling reports must be submitted to EPD until such time as a not is submitted in accordance with part vi.
  - Each permittee must retain copies of all monitoring results reported by that permittee in accordance with this part. in addition to other record keeping requirements, the monitoring information shall include:
    - The date, exact place, and time of sampling or measurements
    - The name(s) of individual(s) who performed the sampling and measurements
    - The date(s) analyses were performed
    - The time(s) analyses were initiated
    - The name(s) of individual(s) who performed the analyses
    - References and written procedures, when available, for the analytical techniques or methods used
    - The results of such analyses, including the bench sheets, instrument readouts, computer disks or tapers, etc. used to determine these results
    - Results which exceed 1000ntu shall be reported as "exceeds 1000ntu"

32. Retention of records:

- Each primary permittee shall retain a copy of the erosion, sedimentation and pollution control plan required by this permit at the construction site or the plan shall be readily available at a designated alternate location from the date of project initiation to the date of final stabilization. primary permittees are encouraged to post copies of their NOI, erosion, sedimentation & pollution control plan, sampling results, inspection reports, etc. on or in a permit board at the construction exit to facilitate inspections by local issuing authorities and EPD.
- Copies of all notices of intent, notices of termination, reports, plans, monitoring reports, monitoring information, including all calibration and maintenance records and all original strip chart recordings for continuous monitoring instrumentation, erosion, sedimentation and pollution control plans, records of all data used to complete the notice of intent to be covered by this permit and all other records required by this permit shall be retained by the permittee who either produced or used it for a period of at least three years from the date that the site is finally stabilized. these records must be maintained at the permittee's primary place of business once the construction activity has ceased at the permitted site. this period may be extended by request of the EPD at any time upon written notification to the permittee.
- Collection and analysis  
This permit requires the monitoring of nephelometric turbidity in receiving water(s) or outfalls in accordance with this permit. this subsection is not applicable to secondary permittees. The following procedures constitute EPD's guidelines for sampling turbidity:
  - Sampling requirements
    - topographic map - see drawing sheet no. C-03-01 for the location of receiving water and outfall discharge and sampling points.
    - Sampling method - samples are to be collected at the designated location downstream of the detention pond either manually or using an automatic sampling system. care shall be taken not to create additional turbidity in the stream during collection of samples.
    - rationale for ntu limits - see ntu table on this sheet.
  - Sample type. all sampling shall be collected by "grab samples" and the analysis of these samples must be conducted in accordance with methodology and test procedures established by 40 cfr part 136 (unless other test procedures have been approved); the guidance document titled "NPDES storm water sampling guidance document, EPA 833-b-92-001" and guidance documents that may be prepared by the EPD
  - Sample containers should be labeled prior to collecting the samples.
    - Samples should be well mixed before transferring to a secondary container.
    - Large mouth, well cleaned and rinsed glass or plastic jars should be used for collecting samples. the jars should be cleaned thoroughly to avoid contamination.
    - Manual, automatic or rising stage sampling may be utilized. samples required by this permit should be analyzed immediately, but no case later than 48 hours after collection. however, samples from automatic samplers must be collected no later than the next business day after their accumulation, unless flow through automatic analysis is utilized. dilution of samples is not required. samples may be analyzed directly with a properly calibrated turbidimeter. samples are not required to be cooled.
    - Sampling and analysis of the receiving water(s) or outfalls beyond the minimum frequency stated in this permit must be reported to EPD as specified in part 1v.e.

Sampling points:  
For construction activities the primary permittee must sample all receiving water(s), or all outfall(s), or combination of receiving water(s) and outfall(s), samples taken for the purpose of compliance with this permit shall be representative of the monitored activity and representative of the water quality of the receiving water(s) and/or the storm water outfalls using the following minimum guidelines:
      - The upstream for each receiving water(s) must be taken immediately upstream of the confluence of the first storm water discharge from the permitted activity (i.e., the discharge farthest upstream at the site) but downstream of other storm water discharges from across the receiving water(s) may need to be taken and the arithmetic average of the turbidity of these samples used for the upstream turbidity value.
      - The downstream sample for each receiving water(s) must be taken downstream of the confluence of the last storm water discharge from the permitted activity (i.e., the discharge not associated with the permitted activity, where appropriate, several downstream samples from across the receiving water(s) may need to be taken and the arithmetic average of the turbidity of these samples used for the downstream turbidity value.
      - Ideally the samples should be taken from the horizontal and vertical center of the receiving water(s) or the storm water outfall channel(s).
      - Care should be taken to avoid stirring the bottom sediments in the receiving water(s) or in the outfall storm water channel.
      - The sampling container should be held so that the opening faces upstream.
      - The samples should be kept free from floating debris.
      - Permittees do not have to sample sheet flow onto undisturbed natural areas stabilized by the projects. for purposes of this section, stabilized shall mean, for unpaired areas and areas not covered by permanent structure edification, 100 uniformly covered in permanent vegetation with a density of 70 the use of rip rap, gabions, permanent mulches or geotextiles) have been used. permanent vegetation shall consist of planted trees, shrubs, perennial vines; a crop of perennial vegetation appropriate for the time of year and region; or a crop of annual vegetation and a seeding of target crop perennials appropriate for the region. final stabilization applies to each phase of construction.
      - All sampling pursuant to this permit must be done in such a way (including generally accepted sampling methods, locations, and frequency) as to accurately reflect whether storm water runoff from the facility/site is in compliance with the standard set forth in parts 111.c.3. or 111. c.4., whichever is applicable.
  - Appendix B rationale for NTU values at all sampling points:
    - SIZE OF SITE: 1.00 - 10.00 ACRES
    - SURFACE WATER DRAINAGE AREA: 5.00 - 9.99 SQUARE MILES
    - TYPE OF RECEIVING WATER: WARM WATER STREAM
    - NTU VALUE: 150

- Sample containers should be labeled prior to collecting the samples.
  - Samples should be well mixed before transferring to a secondary container.
  - Large mouth, well cleaned and rinsed glass or plastic jars should be used for collecting samples. the jars should be cleaned thoroughly to avoid contamination.
  - Manual, automatic or rising stage sampling may be utilized. samples required by this permit should be analyzed immediately, but no case later than 48 hours after collection. however, samples from automatic samplers must be collected no later than the next business day after their accumulation, unless flow through automatic analysis is utilized. dilution of samples is not required. samples may be analyzed directly with a properly calibrated turbidimeter. samples are not required to be cooled.
  - Sampling and analysis of the receiving water(s) or outfalls beyond the minimum frequency stated in this permit must be reported to EPD as specified in part 1v.e.

Sampling points:  
For construction activities the primary permittee must sample all receiving water(s), or all outfall(s), or combination of receiving water(s) and outfall(s), samples taken for the purpose of compliance with this permit shall be representative of the monitored activity and representative of the water quality of the receiving water(s) and/or the storm water outfalls using the following minimum guidelines:
    - The upstream for each receiving water(s) must be taken immediately upstream of the confluence of the first storm water discharge from the permitted activity (i.e., the discharge farthest upstream at the site) but downstream of other storm water discharges from across the receiving water(s) may need to be taken and the arithmetic average of the turbidity of these samples used for the upstream turbidity value.
    - The downstream sample for each receiving water(s) must be taken downstream of the confluence of the last storm water discharge from the permitted activity (i.e., the discharge not associated with the permitted activity, where appropriate, several downstream samples from across the receiving water(s) may need to be taken and the arithmetic average of the turbidity of these samples used for the downstream turbidity value.
    - Ideally the samples should be taken from the horizontal and vertical center of the receiving water(s) or the storm water outfall channel(s).
    - Care should be taken to avoid stirring the bottom sediments in the receiving water(s) or in the outfall storm water channel.
    - The sampling container should be held so that the opening faces upstream.
    - The samples should be kept free from floating debris.
    - Permittees do not have to sample sheet flow onto undisturbed natural areas stabilized by the projects. for purposes of this section, stabilized shall mean, for unpaired areas and areas not covered by permanent structure edification, 100 uniformly covered in permanent vegetation with a density of 70 the use of rip rap, gabions, permanent mulches or geotextiles) have been used. permanent vegetation shall consist of planted trees, shrubs, perennial vines; a crop of perennial vegetation appropriate for the time of year and region; or a crop of annual vegetation and a seeding of target crop perennials appropriate for the region. final stabilization applies to each phase of construction.
    - All sampling pursuant to this permit must be done in such a way (including generally accepted sampling methods, locations, and frequency) as to accurately reflect whether storm water runoff from the facility/site is in compliance with the standard set forth in parts 111.c.3. or 111. c.4., whichever is applicable.
- Appendix B rationale for NTU values at all sampling points:
  - SIZE OF SITE: 1.00 - 10.00 ACRES
  - SURFACE WATER DRAINAGE AREA: 5.00 - 9.99 SQUARE MILES
  - TYPE OF RECEIVING WATER: WARM WATER STREAM
  - NTU VALUE: 150

SITE SIZE, ACRES	SURFACE WATER DRAINAGE AREA, SQUARE MILES							
	0-4.99	5-9.99	10-24.99	25-49.99	50-99.99	100-249.99	250-499.99	500+
1.00-10	75	150	200	400	750	750	750	750
10.001-25	50	100	100	200	300	500	750	750
25.01-50	50	50	100	100	200	300	750	750
50.01-100	50	50	50	100	100	150	300	600
100.01+	50	50	50	50	50	100	200	100

- Sampling point is within the creek adjacent to the southern property line.
  - Initial sediment storage will be provided mainly by a temporary sediment trap. perimeter silt fence and hay bale will provide additional sediment protection for any sediment that by passes the sediment trap.

Intermediate sediment storage will also be provided by the temporary sediment trap for as long as practical during mass grading. silt fence and hay bale will provide some protection.

Final erosion control BMPs will include pipe outlet protection, permanent grassing, sod, check dams to be maintained until permanent grading is fully established.
  - Graphic scale and north arrows are shown on ES&PC plans.
  - Existing and proposed contour lines are at 1ft intervals in accordance with the following table:
- | Map Scale                      | Ground Slope                                | Contour Intervals, ft            |
|--------------------------------|---|----------------------------------|
| 1 inch = 100ft or larger scale | Flat 0 - 2%<br>Rolling 2 - 8%<br>Steep 8% + | 0.5 or 1<br>1 or 2<br>2, 5 or 10 |
- No alternate BMPs are used on this site.
  - No alternate BMPs are used on this site.
  - There is state waters on the site and the applicable buffer delineations are shown on the plans. All land-disturbing activities will be outside of the designated buffers.

- No delineation of wetlands required because there is no wetland on site.
- The contributing drainage area on the site is 4.66 ac
- Maps of drainage basins for both pre- and post-developed conditions included in the ES&PC Plan.
- Estimate of runoff coefficient and peak discharge flow:

	Pre-Construction	Post-Construction
Runoff Curve Number		
2Yr Peak Flow (cfs)		
25Yr Peak Flow (cfs)		
100Yr Peak Flow (cfs)		

- All storm drain pipes and hydraulic information are shown on erosion control plans.
- Soil series on site are TOCOA SANDY LOAM AND CHESTATEE STONY LOAM are delineated on the ES&PC Plan.
- The limits of disturbance is 1.13ac and are shown on the ES&PC Plan.
- The combination of sediment traps and silt fences will provide minimum 67 cubic yards of sediment storage per acre drained.
- Location of Best Management Practices are shown on the ES&PC Plan
- Detailed drawings for all structural practices are provided on the Structural Detail Plan.
- Vegetative plans are provided on the Structural Detail Plan.

**PRODUCT SPECIFIC PRACTICES**

- Petroleum based product: Containers for products such as fuels, lubricants and tars will be inspected daily for leaks and spills. This includes on-site vehicle and machinery daily inspections and regular preventative maintenance of such equipment. Equipment maintenance areas will be located away from state water, natural drains and storm water drainage inlets. In addition, temporary fueling tanks shall have a secondary containment liner to prevent/minimize site contamination. Discharge of oils, fuels and lubricants is prohibited. Proper disposal methods will include collection in a suitable container and disposal as required by local and State regulations.
- Paints/Finishes/Solvents: All products will be stored in tightly sealed original containers when not in use. Excess product will not be discharged to the storm water collection system. Excess product, materials used with these products and product containers will be disposed of according to manufacturer's specifications and recommendations.
- Fertilizer/Herbicides: These products will be applied at rates that do not exceed the manufacturer's specifications or above the guidelines set forth in the GSWCC Manual for Erosion and Sediment Control in Georgia. Any storage of these materials will be under roof in sealed containers.
- Building materials: No building or construction materials will be buried or disposed of onsite. All such material will be disposed of in proper waste disposal procedures.
- Waste disposal: Keep Porta-Johns away from storm drain inlets and receiving bodies of water or rinsing of Porta-Johns into storm inlets or receiving bodies of water. Runoff from Porta-Johns into water systems is a violation of Federal, State, and Local ordinances.
- Mulch: Mulch storage must comply with the following section of the standard fire prevention code. Section 502.3.1 - No person shall store in any building or upon any premises in excess of 2,500 cu.ft. gross volume of combustible empty packing cases, boxes, barrels or similar containers, or rubber tires, or rubber or other similarly combustible materials without a permit.

**OWNER / DEVELOPER**  
CITY OF STONECREST  
3120 STONECREST BLVD.  
STONECREST, GA 30038  
TEL: 770-224-0200  
CONTACT: HARI KARIKARAN  
EMAIL: hkarikaran@stonecrestga.gov  
www.stonecrestga.gov

**ENGINEER**  
CERM  
1990 LAKESIDE PARKWAY STE 300  
TUCKER, GA 30084  
TEL: 678-999-0173  
CONTACT: YASMIN MORENO, P.E.  
EMAIL: ymoreno@cerm.com  
www.cerm.com

**24 HOUR EROSION CONTROL CONTACT:**  
NAME: 24 HOUR CONTACT  
JONATHAN WALKER  
404-546-3793

TOTAL AREA OF SITE :4.66 AC  
DISTURBED AREA ON SITE : 1.13 AC  
SOIL CLASS: Tt

**GSWCC** GEORGIA SOIL AND WATER CONSERVATION COMMISSION

Yasmin Moreno  
Level II Certified Design Professional

CERTIFICATION NUMBER: 0000029509  
ISSUED: 06/27/2021 EXPIRES: 06/27/2024



CLIENT:  
**STONECREST**  
City of Stonecrest  
3120 Stonecrest Blvd  
Stonecrest, GA 30038  
770-224-0200

REVISIONS

NO.	DATE	DESCRIPTION

**CERM**  
1990 Lakeside Parkway  
Suite 300  
Tucker, GA, 30084  
O: 678.999.0173  
F: 678.999.0186  
[www.cerm.com](http://www.cerm.com)

PROJECT:  
PANOLA SHOALS RIVERBANK STABILIZATION AND RESTORATION PROJECT  
TAX ID: 16 016 03 002  
LAND LOT 17 16th DISTRICT CITY OF STONECREST DEKALB COUNTY, GEORGIA

**DESIGN TEAM**

DESIGN BY	CN
DRAWN BY	JD
CHECKED BY	YM

CERM PROJECT NO. 1468A-000A  
CLIENT PROJECT NO. 21-06210-Co018-00

**DATE**  
JUNE 29, 2022

**SHEET TITLE**  
**NPDES POLLUTION PREVENTION PLAN**

**SHEET No**  
**C-08-01**

**EROSION, SEDIMENTATION & POLLUTION CONTROL PLAN CHECKLIST**  
**STAND ALONE CONSTRUCTION PROJECTS**

SWCD: FULTON COUNTY

Project Name: SOUTH RIVER STREAM BANK RESTORATION Address: CITY OF STONECREST, GA  
City/County: CITY OF STONECREST Date on Plans: 05/11/2022

Name & email of person filling out checklist: YASMIN MORENO, ymoreno@cerm.com

Plan Included  
Page # Y/N  
**TO BE SHOWN ON ES&PC PLAN**

- |                    |   |  |
|--------------------|---|--|
| C-08-02            | Y | 1 The applicable Erosion, Sedimentation and Pollution Control Plan Checklist established by the Commission as of January 1 of the year in which the land-disturbing activity was permitted.<br>(The completed Checklist must be submitted with the ES&PC Plan or the Plan will not be reviewed)  |
| C-08-01<br>C-08-05 | Y | 2 Level II certification number issued by the Commission, signature and seal of the certified design professional. (Signature, seal and Level II number must be on each sheet pertaining to ES&PC plan or the Plan will not be reviewed)   |
| N/A                | N | 3 Limits of disturbance shall be no greater than 50 acres at any one time without prior written authorization from the EPD District Office. If EPD approves the request to disturb 50 acres or more at any one time, the Plan must include at least 4 of the BMPs listed in Appendix 1 of this checklist.<br>(A copy of the written approval by EPD must be attached to the plan for the Plan to be reviewed.)     |
| C-08-01<br>C-08-05 | Y | 4 The name and phone number of the 24-hour local contact responsible for erosion, sedimentation and pollution controls.  |
| C-08-01            | Y | 5 Provide the name, address, email address, and phone number of primary permittee.   |
| C-08-01            | Y | 6 Note total and disturbed acreage of the project or phase under construction.   |
| C-08-01            | Y | 7 Provide the GPS location of the construction exit for the site. Give the Latitude and Longitude in decimal degrees.  |
| C-08-03            | Y | 8 Initial date of the Plan and the dates of any revisions made to the Plan including the entity who requested the revisions.   |
| C-08-01            | Y | 9 Description of the nature of construction activity and existing site conditions.   |
| C-08-03            | Y | 10 Provide vicinity map showing site's relation to surrounding areas. Include designation of specific phase, if necessary.   |
| C-08-01            | Y | 11 Identify the project receiving waters and describe all sensitive adjacent areas including streams, lakes, residential areas, wetlands, marshlands, etc. which may be affected.  |
| C-08-01            | Y | 12 Design professional's certification statement and signature that the site was visited prior to development of the ES&PC Plan as stated on Part IV page 19 of the permit.  |
| C-08-01            | Y | 13 Design professional's certification statement and signature that the permittee's ES&PC Plan provides for an appropriate and comprehensive system of BMPs and sampling to meet permit requirements as stated on Part IV page 19 of the permit.*  |
| C-08-01            | Y | 14 Clearly note the statement that "The design professional who prepared the ES&PC Plan is to inspect the installation of the initial sediment storage requirements and perimeter control BMPs within 7 days after installation."<br>in accordance with Part IV.A.5 page 25 of the permit.*  |
| C-08-01            | Y | 15 Clearly note the statement that "Non-exempt activities shall not be conducted within the 25 or 50-foot undisturbed stream buffers as measured from the point of wrested vegetation or within 25-feet of the coastal marshland buffer as measured from the Jurisdictional Determination Line without first acquiring the necessary variances and permits."   |
| C-08-01            | Y | 16 Provide a description of any buffer encroachments and indicate whether a buffer variance is required.   |
| C-08-01            | Y | 17 Clearly note the statement that "Amendments/revisions to the ES&PC Plan which have a significant effect on BMPs with a hydraulic component must be certified by the design professional.**"   |
| C-08-01            | Y | 18 Clearly note the statement that "Waste materials shall not be discharged to waters of the State, except as authorized by a Section 404 permit.**"   |
| C-08-01            | Y | 19 Clearly note statement that "The escape of sediment from the site shall be prevented by the installation of erosion and sediment control measures and practices prior to land disturbing activities."   |
| C-08-01            | Y | 20 Clearly note statement that "Erosion control measures will be maintained at all times. If full implementation of the approved Plan does not provide for effective erosion control, additional erosion and sediment control measures shall be implemented to control or treat the sediment source."  |
| C-08-01            | Y | 21 Clearly note the statement "Any disturbed area left exposed for a period greater than 14 days shall be stabilized with mulch or temporary seeding."   |
| C-08-01            | Y | 22 Any construction activity which discharges storm water into an Impaired Stream Segment, or within 1 linear mile upstream of and within the same watershed as, any portion of an Biota Impaired Stream Segment must comply with Part III. C. of the permit. Include the completed Appendix 1 listing all the BMPs that will be used for those areas of the site which discharge to the Impaired Stream Segment." |
| C-08-01            | Y | 23 If a TMDL Implementation Plan for sediment has been finalized for the Impaired Stream Segment (identified in Item 22 above) at least six months prior to submittal of NOI, the ES&PC Plan must address any site-specific conditions or requirements included in the TMDL Implementation Plan."  |
| C-08-01            | Y | 24 BMPs for concrete washdown of tools, concrete mixer chutes, hoppers and the rear of the vehicles. Washout of the drum at the construction site is prohibited."  |
| C-08-01            | Y | 25 Provide BMPs for the remediation of all petroleum spills and leaks.   |
| C-08-01            | Y | 26 Description of the measures that will be installed during the construction process to control pollutants in storm water that will occur after construction operations have been completed."   |
| C-08-01            | Y | 27 Description of practices to provide cover for building materials and building products on site."  |
| C-08-01            | Y | 28 Description of the practices that will be used to reduce the pollutants in storm water discharges."   |
| C-08-01            | Y | 29 Description and chart or timeline of the intended sequence of major activities which disturb soils for the major portions of the site (i.e., initial perimeter and sediment storage BMPs, clearing and grubbing activities, excavation activities, utility activities, temporary and final stabilization).  |
| C-08-01            | Y | 30 Provide complete requirements of inspections and record keeping by the primary permittee."  |
| C-08-01            | Y | 31 Provide complete requirements of sampling frequency and reporting of sampling results."   |
| C-08-01            | Y | 32 Provide complete details for retention of records as per Part IV.F. of the permit."   |
| C-08-01            | Y | 33 Description of analytical methods to be used to collect and analyze the samples from each location."  |

C-08-01 Y 34 Appendix B rationale for NTU values at all outfall sampling points where applicable.\*

C-08-01 Y 35 Delineate all sampling locations, perennial and intermittent streams and other water bodies into which storm water is discharged.\*

C-08-01 Y 36 A description of appropriate controls and measures that will be implemented at the construction site including: (1) initial sediment storage requirements and perimeter control BMPs, (2) intermediate grading and drainage BMPs, and (3) final BMPs. For construction sites where there will be no mass grading and the initial perimeter control BMPs, intermediate grading and drainage BMPs, and final BMPs are the same, the Plan may combine all of the BMPs into a single phase.\*

C-08-03 Y 37 Graphic scale and North arrow.

C-08-04 Y 38 Existing and proposed contour lines with contour lines drawn at an interval in accordance with the following:

Map Scale	Ground Slope	Contour Intervals, ft.
1 inch = 100ft or larger scale	Flat 0 - 2% Rolling 2 - 8% Steep 8% +	0.5 or 1 1 or 2 2.5 or 10

N/A N 39 Use of alternative BMPs whose performance has been documented to be equivalent to or superior to conventional BMPs as certified by a Design Professional (unless disapproved by EPD or the Georgia Soil and Water Conservation Commission). Please refer to the Alternative BMP Guidance Document found at [www.gaswcc.org](http://www.gaswcc.org).

N/A N 40 Use of alternative BMP for application to the Equivalent BMP List. Please refer to Appendix A-2 of the Manual for Erosion & Sediment Control in Georgia 2016 Edition.\*

C-08-03 Y 41 Delineation of the applicable 25-foot or 50-foot undisturbed buffers adjacent to state waters and any additional buffers required by the Local Issuing Authority. Clearly note and delineate all areas of impact.

C-08-03 Y 42 Delineation of on-site wetlands and all state waters located on and within 200 feet of the project site.

N/A N 43 Delineation and acreage of contributing drainage basins on the project site.

Hydro Y 44 Provide hydrology study and maps of drainage basins for both the pre- and post-developed conditions.\*

C-08-01 Y 45 An estimate of the runoff coefficient or peak discharge flow of the site prior to and after construction activities are completed.

N/A N 46 Storm-drain pipe and weir velocities with appropriate outlet protection to accommodate discharges without erosion. Identify/Delineate all storm water discharge points.

C-08-03 Y 47 Soil series for the project site and their delineation.

C-08-04 Y 48 The limits of disturbance for each phase of construction.

C-08-03 Y 49 Provide a minimum of 67 cubic yards of sediment storage per acre drained using a temporary sediment basin, retrofitted detention pond, and/or excavated inlet sediment traps for each common drainage location. Sediment storage volume must be in place prior to and during all land disturbance activities until final stabilization of the site has been achieved. A written justification explaining the decision to use equivalent controls when a sediment basin is not attainable must be included in the Plan for each common drainage location in which a sediment basin is not provided. A written justification as to why 67 cubic yards of storage is not attainable must also be given. Worksheets from the Manual included for structural BMPs and all calculations used by the storage design professional to obtain the required sediment when using equivalent controls. When discharging from sediment basins and impoundments, permittees are required to utilize outlet structures that withdraw water from the surface, unless infeasible. If outlet structures that withdraw water from the surface are not feasible, a written justification explaining this decision must be included in the Plan.

C-08-01 Y 50 Location of Best Management Practices that are consistent with and no less stringent than the Manual for Erosion and Sediment Control in Georgia. Use uniform coding symbols from the Manual, Chapter 6, with legend.

C-08-05 Y 51 Provide detailed drawings for all structural practices. Specifications must, at a minimum, meet the guidelines set forth in the Manual for Erosion and Sediment Control in Georgia.

C-08-08 Y 52 Provide vegetative plan, noting all temporary and permanent vegetative practices. Include species, planting dates and seeding, fertilizer, lime and mulching rates. Vegetative plan shall be site specific for appropriate time of the year that seeding will take place and for the appropriate geographic region of Georgia.

\*If using this checklist for a project that is less than 1 acre and not part of a common development but within 200 ft of a perennial stream the \* checklist items would be N/A.

Effective January 1, 2021

**24 HOUR EROSION CONTROL CONTACT:**

NAME: 24 HOUR CONTACT

JONATHAN WALKER

404-546-3793



**Yasmin Moreno**  
Level II Certified Design Professional

CERTIFICATION NUMBER: 000029509  
ISSUED: 06/27/2021 EXPIRES: 06/27/2024

OWNER / DEVELOPER  
CITY OF STONECREST  
3120 STONECREST BLVD.  
STONECREST, GA 30038  
TEL: 770-224-0200  
CONTACT: HARI KARIKARAN  
EMAIL: [hkarikaran@stonecrestga.gov](mailto:hkarikaran@stonecrestga.gov)  
[www.stonecrestga.gov](http://www.stonecrestga.gov)

ENGINEER  
CERM  
1990 LAKESIDE PARKWAY STE 300  
TUCKER, GA 30084  
TEL: 678-999-0173  
CONTACT: YASMIN MORENO, P.E.  
EMAIL: [ymoreno@cerm.com](mailto:ymoreno@cerm.com)  
[www.cerm.com](http://www.cerm.com)



PRIOR TO DIGGING  
VERIFY LOCATION  
OF EXISTING UTILITIES  
AND CONTACT GEORGIA 811  
<https://www.georgia811.com/>

CLIENT:



City of Stonecrest  
3120 Stonecrest Blvd  
Stonecrest, GA 30038  
770-224-0200

REVISIONS		
NO.	DATE	DESCRIPTION



1990 Lakeside Parkway  
Suite 300  
Tucker, GA, 30084  
O: 678.999.0173  
F: 678.999.0186  
[www.cerm.com](http://www.cerm.com)

PROJECT: PANOLA SHOALS RIVERBANK STABILIZATION AND RESTORATION PROJECT  
TAX ID: 16 016 03 002  
LAND LOT 17 16th DISTRICT  
CITY OF STONECREST  
DEKALB COUNTY, GEORGIA

DESIGN TEAM	
DESIGN BY	CN
DRAWN BY	JD
CHECKED BY	YM

CERM PROJECT NO. 1468A-000A  
CLIENT PROJECT NO. 21-06210-Co018-00

**DATE**  
JUNE 29, 2022

**SHEET TITLE**

**NPDES CHECKLIST**

**SHEET No**

**C-08-02**

**EROSION CONTROL NOTES:**

- THE ESCAPE OF SEDIMENT FROM THE SITE SHALL BE PREVENTED BY THE INSTALLATION OF EROSION AND SEDIMENT CONTROL MEASURES AND PRACTICES PRIOR TO, OR CONCURRENT WITH LAND DISTURBING ACTIVITIES.
- EROSION CONTROL MEASURES WILL BE MAINTAINED AT ALL TIMES. IF FULL IMPLEMENTATION OF THE APPROVED PLAN DOES NOT PROVIDE FOR EFFECTIVE EROSION CONTROL, ADDITIONAL EROSION AND SEDIMENTATION CONTROL MEASURES SHALL BE IMPLEMENTED TO CONTROL OR TREAT THE SEDIMENT SOURCE.
- SEDIMENT STORAGE MAINTENANCE INDICATORS MUST BE INSTALLED IN SEDIMENT STORAGE STRUCTURES INDICATING THE 2/3 FULL VOLUME.
- MAINTENANCE OF ALL SOIL EROSION AND SEDIMENTATION CONTROL MEASURES AND PRACTICES, WHETHER TEMPORARY OR PERMANENT, SHALL BE AT ALL TIMES THE RESPONSIBILITY OF THE PROPERTY OWNER.
- A 50-FOOT UNDISTURBED BUFFER AND A 75-FOOT IMPERVIOUS SETBACK IS TO BE MAINTAINED ADJACENT TO ALL STREAMS.
- WHERE APPLICABLE, DETENTION POND, DETENTION OUTLET STRUCTURES, AND TEMPORARY SEDIMENT POND FEATURES ARE TO BE CONSTRUCTED AND FULLY OPERATIONAL PRIOR TO ANY OTHER CONSTRUCTION OR GRADING.
- DISTURBED AREAS SHALL BE STABILIZED WITH TEMPORARY VEGETATION OR MULCH IF LAND DISTURBING ACTIVITIES CEASE FOR MORE THAN 14 CALENDAR DAYS.
- ALL FILL SLOPES SHALL HAVE SILT FENCE PLACED AT THE SLOPE'S TOE.
- CONCENTRATED FLOW AREAS AND ALL SLOPES STEEPER THAN 2.5:1 WITH A HEIGHT OF 10 FEET OR GREATER SHALL BE STABILIZED WITH THE APPROPRIATE EROSION CONTROL MATTING OR BLANKET.
- THE PROFESSIONAL WHO SEALS THIS PLAN CERTIFIES UNDER PENALTY OF LAW THAT THIS PLAN WAS PREPARED AFTER A SITE VISIT TO THE LOCATIONS DESCRIBED HEREIN BY THE PROFESSIONAL'S AUTHORIZED AGENT, UNDER THE PROFESSIONAL'S SUPERVISION.
- UPON NOTIFICATION AND AUTHORIZATION OF THE OWNER, THE DESIGN PROFESSIONAL WHO PREPARED THE ES&SO PLAN IS RESPONSIBLE FOR INSPECTING THE INSTALLATION OF THE BMP'S WITHIN 7 DAYS AFTER INITIAL CONSTRUCTION ACTIVITIES BEGINS.
- GA SWCC LEVEL II DESIGN PROFESSIONAL CERTIFICATION NUMBER IS 24059 AND SIGNATURE IS ATTACHED.
- THE SOIL EROSION AND SEDIMENT CONTROL ORDINANCE REQUIRES THAT A 25 FOOT BUFFER ADJACENT TO ALL STATE WATERS BE MAINTAINED (ARTICLE 4 SECTION 4.3 PARAGRAPH 15). AN EXCEPTION IS GRANTED TO HOMEOWNERS WHO PERFORM MINOR LAND DISTURBING ACTIVITIES SUCH AS HOME LANDSCAPING, HOME GARDENS AND MAINTENANCE WORK (ARTICLE 3, SECTION 1, PARAGRAPH 3).
- ALL WORK SHALL BE PERFORMED IN ACCORDANCE WITH THE STANDARDS AND SPECIFICATIONS OF THE PUBLICATION ENTITLED "MANUAL FOR EROSION AND SEDIMENT CONTROL IN GEORGIA".
- CONSTRUCTION ACTIVITIES WILL BE PERFORMED IN COMPLIANCE WITH ALL APPLICABLE LAWS, RULES, AND REGULATIONS.
- TEMPORARY EROSION CONTROL DEVICES MUST BE IN PLACE AND OPERATIONAL PRIOR TO CLEARING AND GRADING OPERATIONS.
- REPLACE CLOGGED SECTIONS OF SILT FENCES AS NECESSARY TO MAINTAIN WATER PASSAGE.
- STABILIZE ALL SLOPES AND BARE AREAS AS SOON AS POSSIBLE AFTER GRADING OPERATIONS ARE COMPLETE.
- SEDIMENT AND EROSION CONTROL MEASURES SHALL BE INSPECTED DAILY. ANY DAMAGES OBSERVED WILL BE REPAIRED BY END OF THE DAY.
- STONE FOR CONSTRUCTION EXIT TO BE A S.T.M.D. 448 SIZE#1 (1-3/4" TO 3-3/4" IN DIAMETER). THE EXIT MUST BE MAINTAINED IN CONDITION TO PREVENT TRACKING OR FLOW OF MUD FROM GRADING OPERATIONS. CONTRACTOR TO APPLY PERIODIC DRESSING TO CONSTRUCTION EXIT WITH #1 STONE AS REQUIRED.
- PERMANENT EROSION CONTROL MUST BE ACHIEVED PRIOR TO REMOVAL OF TEMPORARY EROSION CONTROL DEVICES.
- EROSION CONTROL DEVICES SHOWN HEREON ARE TO BE CONSIDERED A MINIMUM. ADDITIONAL MEASURES ARE TO BE INSTALLED IF DEEMED NECESSARY BY AN ON-SITE INSPECTION.
- THE INSTALLATION OF EROSION AND SEDIMENT CONTROL MEASURES AND PRACTICES SHALL OCCUR PRIOR TO OR CONCURRENT WITH LAND DISTURBING ACTIVITIES.
- CONTRACTOR TO PROVIDE WHEEL WASH AREA CLOSE TO THE CONSTRUCTION EXIT TO REMOVE EXCESS DIRT FROM CONSTRUCTION VEHICLES BEFORE ENTERING THE PUBLIC ROADWAY.
- THE PRIMARY PERMITTEE MUST SAMPLE ALL RECEIVING WATER(S), OR ALL OUTFALL(S), OR A COMBINATION OF RECEIVING WATERS AND OUTFALL(S). RECEIVING WATERS MUST HAVE AN UPSTREAM AND A DOWNSTREAM SAMPLE LOCATION.
- ANY DISTURBED AREA LEFT EXPOSED FOR A PERIOD GREATER THAN 14 DAYS SHALL BE STABILIZED WITH MULCH OR TEMPORARY SEEDING.

CODE	PRACTICE	DETAIL	MAP SYMBOL	DESCRIPTION
Co	CONSTRUCTION EXIT			A crushed stone pad located at the construction site exit to provide a place for removing mud from tires thereby protecting public streets.
Cd	CHECKDAM			A small temporary barrier or dam constructed across a swale, drainage ditch or area of concentrated flow.
Sd1	SEDIMENT BARRIER			A barrier to prevent sediment from leaving the construction site. It may be sandbags, bales of straw or hay, brush, logs and poles, gravel, or a silt fence.
Sd2	INLET SEDIMENT TRAP			An impounding area created by excavating around a storm drain drop inlet. The excavated area will be filled and stabilized on completion of construction activities.
Sd3	TEMPORARY SEDIMENT BASIN			A basin created by excavation or a dam across a waterway. The surface water runoff is temporarily stored allowing the bulk of the sediment to drop out.
Ds1	DISTURBED AREA STABILIZATION (WITH MULCHING ONLY)			Establishing temporary protection for disturbed areas where seedlings may not have a suitable growing season to produce an erosion retarding cover.
Ds2	DISTURBED AREA STABILIZATION (WITH TEMP. SEEDING)			Establishing a temporary vegetative cover with fast growing seedlings on disturbed areas.
Ds3	DISTURBED AREA STABILIZATION (WITH PERM. SEEDING)			Establishing a permanent vegetative cover such as trees, shrubs, vines, grasses, or legumes on disturbed areas.
Ds4	DISTURBED AREA STABILIZATION (SOODING)			A permanent vegetative cover using sods on highly erodible or critically eroded lands.
Tr	TREE PROTECTION FENCE			To protect desirable trees from injury during construction activity.
St	STORM DRAIN OUTLET PROTECTION			A paved or short section of riprap channel at the outlet of a storm drain system preventing erosion from the concentrated runoff.
Tc-S	TURBIDITY CURTAIN			A floating or stacked barrier installed within the water (it may also be referred to as a floating boom, silt barrier, or silt curtain).
Ss	SLOPE STABILIZATION			A protective covering used to prevent erosion and establish temporary or permanent vegetation on steep slopes, shore lines, or channels.
Re	RETAINING WALL			A wall installed to stabilize cut and fill slopes where maximum permissible slopes are not obtainable. Each situation will require special design.

PRIMARY PERMITTEE:  
CITY OF STONECREST

24-HOUR CONTACT  
DAVID ASBELL  
TEL: 678-283-2938

ENGINEER  
CERM  
1990 LAKESIDE PARKWAY STE 300  
TUCKER, GA 30084  
TEL: 678-999-0173  
CONTACT: YASMIN MORENO, P.E.  
EMAIL: ymoreno@cerm.com  
www.cerm.com

OWNER / DEVELOPER  
CITY OF STONECREST  
3120 STONECREST BLVD.  
STONECREST, GA 30038  
TEL: 770-224-0200  
CONTACT: HARI KARIKARAN  
EMAIL: hkariaran@stonecrestga.gov  
www.stonecrestga.gov

**STATEMENT**

I CERTIFY UNDER PENALTY OF LAW THAT THIS PLAN WAS PREPARED AFTER A SITE VISIT TO THE LOCATIONS DESCRIBED HEREIN BY MYSELF OR MY AUTHORIZED AGENT, UNDER MY DIRECT SUPERVISION.

SIGNATURE

05-04-2022  
DATE

**LEGEND**

- EXISTING PAVEMENT
- LIMIT OF DISTURBANCE
- CONTRACTOR'S LAYDOWN AREA
- PROJECT LIMITS

**GRAPHIC SCALE**

(IN FEET)  
1 inch = 30 ft

SOIL GROUP BOUNDARY



SOIL MAP

LAT: 33°39'16.69"N,  
LONG: 84°11'8.07"W

REVISIONS

NO.	DATE	DESCRIPTION

1990 Lakeside Parkway  
Suite 300  
Tucker, GA, 30084  
O: 678.999.0173  
F: 678.999.0186  
[www.cerm.com](http://www.cerm.com)

PROJECT:  
PANOLA SHOALS RIVERBANK STABILIZATION AND RESTORATION PROJECT  
TAX ID: 16 016 03 002  
LAND LOT 17 16th DISTRICT CITY OF STONECREST DEKALB COUNTY, GEORGIA

DESIGN TEAM

DESIGN BY	CN
DRAWN BY	JD
CHECKED BY	YM

CERM PROJECT NO. 1468A-000A  
CLIENT PROJECT NO. 21-06210-Co018-00

DATE  
JUNE 29, 2022  
SHEET TITLE

INITIAL EROSION CONTROL PLAN

SHEET No  
C-08-03

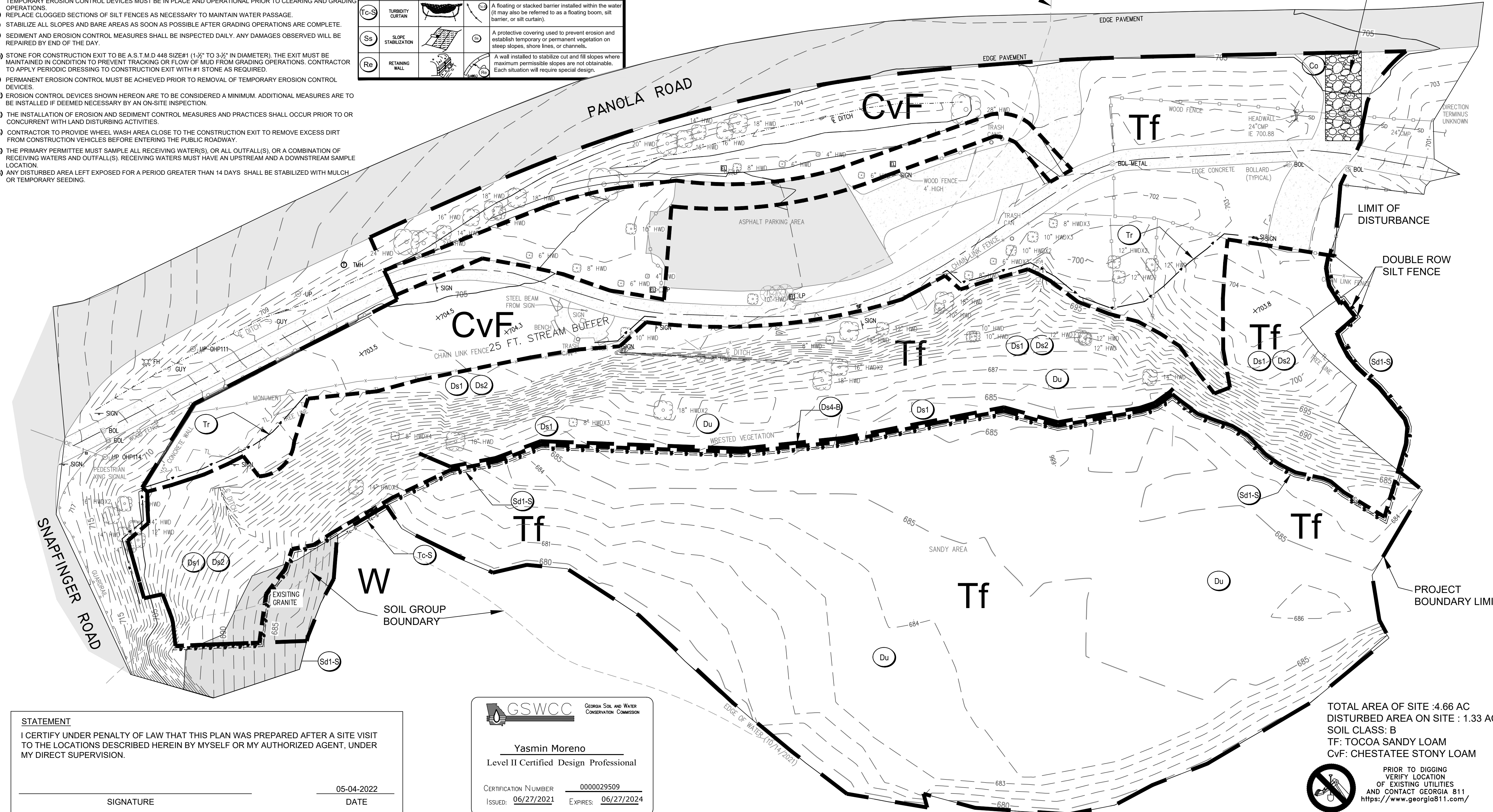

**STATEMENT**

I CERTIFY UNDER PENALTY OF LAW THAT THIS PLAN WAS PREPARED AFTER A SITE VISIT TO THE LOCATIONS DESCRIBED HEREIN BY MYSELF OR MY AUTHORIZED AGENT, UNDER MY DIRECT SUPERVISION.

\_\_\_\_\_  
SIGNATURE

05-04-2022  
DATE

**GSWCC** GEORGIA SOIL AND WATER CONSERVATION COMMISSION

Yasmin Moreno  
Level II Certified Design Professional

CERTIFICATION NUMBER: 0000029509  
ISSUED: 06/27/2021 EXPIRES: 06/27/2024

TOTAL AREA OF SITE : 4.66 AC  
DISTURBED AREA ON SITE : 1.33 AC  
SOIL CLASS: B  
TF: TOCOA SANDY LOAM  
CVF: CHESTATEE STONY LOAM

PRIOR TO DIGGING VERIFY LOCATION OF EXISTING UTILITIES AND CONTACT GEORGIA 811 <https://www.georgia811.com/>

CODE	PRACTICE	DETAIL	MAP SYMBOL	DESCRIPTION
Co	CONSTRUCTION EXIT			A crushed stone pad located at the construction site exit to provide a place for removing mud from tires thereby protecting public streets.
Cd	CHECKDAM			A small temporary barrier or dam constructed across a swale, drainage ditch or area of concentrated flow.
Sd1	SEDIMENT BARRIER			A barrier to prevent sediment from leaving the construction site. It may be sandbags, bales of straw or hay, brush, logs and poles, gravel, or a silt fence.
Sd2	INLET SEDIMENT TRAP			An impounding area created by excavating around a storm drain inlet. The excavated area will be filled and stabilized on completion of construction activities.
Sd3	TEMPORARY SEDIMENT BASIN			A basin created by excavation or a dam across a waterway. The surface water runoff is temporarily stored allowing the bulk of the sediment to drop out.
Ds1	DISTURBED AREA STABILIZATION (WITH MULCHING ONLY)			Establishing temporary protection for disturbed areas where seedlings may not have a suitable growing season to produce an erosion retarding cover.
Ds2	DISTURBED AREA STABILIZATION (WITH TEMP SEEDING)			Establishing a temporary vegetative cover with fast growing seedlings on disturbed areas.
Ds3	DISTURBED AREA STABILIZATION (WITH PERM SEEDING)			Establishing a permanent vegetative cover such as trees, shrubs, vines, grasses, or legumes on disturbed areas.
Ds4	DISTURBED AREA STABILIZATION (SOODING)			A permanent vegetative cover using sods on highly erodible or critically eroded lands.
Tr	TREE PROTECTION FENCE			To protect desirable trees from injury during construction activity.
St	STORMWATER OUTLET PROTECTION			A paved or short section of riprap channel at the outlet of a storm drain system preventing erosion from the concentrated runoff.
Tc-S	TURBIDITY CURTAIN			A floating or stacked barrier installed within the water (it may also be referred to as a floating boom, silt barrier, or silt curtain).
Ss	SLOPE STABILIZATION			A protective covering used to prevent erosion and establish temporary or permanent vegetation on steep slopes, shore lines, or channels.
Re	RETAINING WALL			A wall installed to stabilize cut and fill slopes where maximum permissible slopes are not obtainable. Each situation will require special design.

**LEGEND**

- PROPOSED PEDESTRIAN TRAIL
- LIMIT OF DISTURBANCE
- EXISTING PAVEMENT
- PROPOSED FENCE
- CONTRACTOR'S LAYDOWN AREA
- CONTRACTOR'S SECURE GATE
- PROJECT LIMITS

PRIMARY PERMITTEE:  
CITY OF STONECREST

24-HOUR CONTACT  
DAVID ASBELL  
TEL: 678-283-2938

ENGINEER  
CERM  
1990 LAKESIDE PARKWAY STE 300  
TUCKER, GA 30084  
TEL: 678-999-0173  
CONTACT: YASMIN MORENO, P.E.  
EMAIL: ymoreno@cerm.com  
www.cerm.com

OWNER / DEVELOPER  
CITY OF STONECREST  
3120 STONECREST BLVD.  
STONECREST, GA 30038  
TEL: 770-224-0200  
CONTACT: HARI KARIKARAN  
EMAIL: hkarikaran@stonecrestga.gov  
www.stonecrestga.gov

STATEMENT  
I CERTIFY UNDER PENALTY OF LAW THAT THIS PLAN WAS PREPARED AFTER A SITE VISIT TO THE LOCATIONS DESCRIBED HEREIN BY MYSELF OR MY AUTHORIZED AGENT, UNDER MY DIRECT SUPERVISION.

\_\_\_\_\_  
SIGNATURE

05-04-2022  
DATE

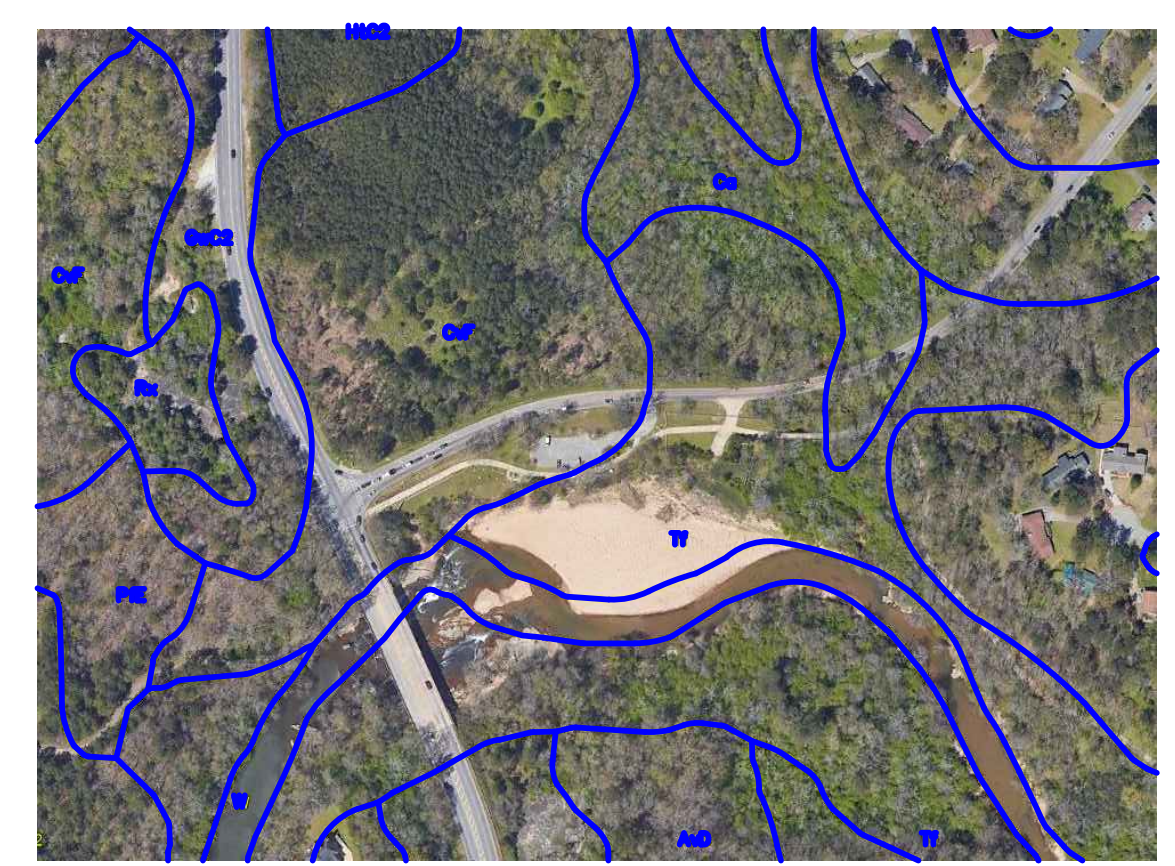
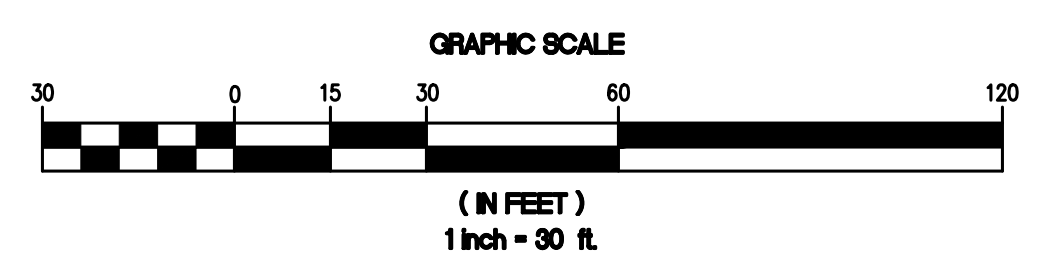

SOIL MAP  
LAT: 33°39'16.69"N,  
LONG: 84°11'8.07"W

CLIENT:  
**STONECREST**  
City of Stonecrest  
3120 Stonecrest Blvd  
Stonecrest, GA 30038  
770-224-0200

REVISIONS		
NO.	DATE	DESCRIPTION

**CERM**  
1990 Lakeside Parkway  
Suite 300  
Tucker, GA, 30084  
O: 678.999.0173  
F: 678.999.0186  
[www.cerm.com](http://www.cerm.com)

PROJECT:  
PANOLA SHOALS RIVERBANK STABILIZATION  
AND RESTORATION PROJECT  
TAX ID: 16 016 03 002  
LAND LOT 17 16th DISTRICT  
CITY OF STONECREST  
DEKALB COUNTY, GEORGIA

DESIGN TEAM	
DESIGN BY	CN
DRAWN BY	JD
CHECKED BY	YM
CERM PROJECT NO. 1468A-000A	
CLIENT PROJECT NO. 21-06210-Co018-00	
DATE	JUNE 29, 2022
SHEET TITLE	
<b>INTERMEDIATE EROSION CONTROL PLAN</b>	
SHEET No	
<b>C-08-04</b>	

C:\Project\_Operations\Projects\Active Projects\2021-1468A-000A City of Stonecrest South River Stream Bank Restoration\40 - Design Documents\02 Plans\C-08 Erosion Control Plan.dwg Jul 06, 2022 - 5:28pm

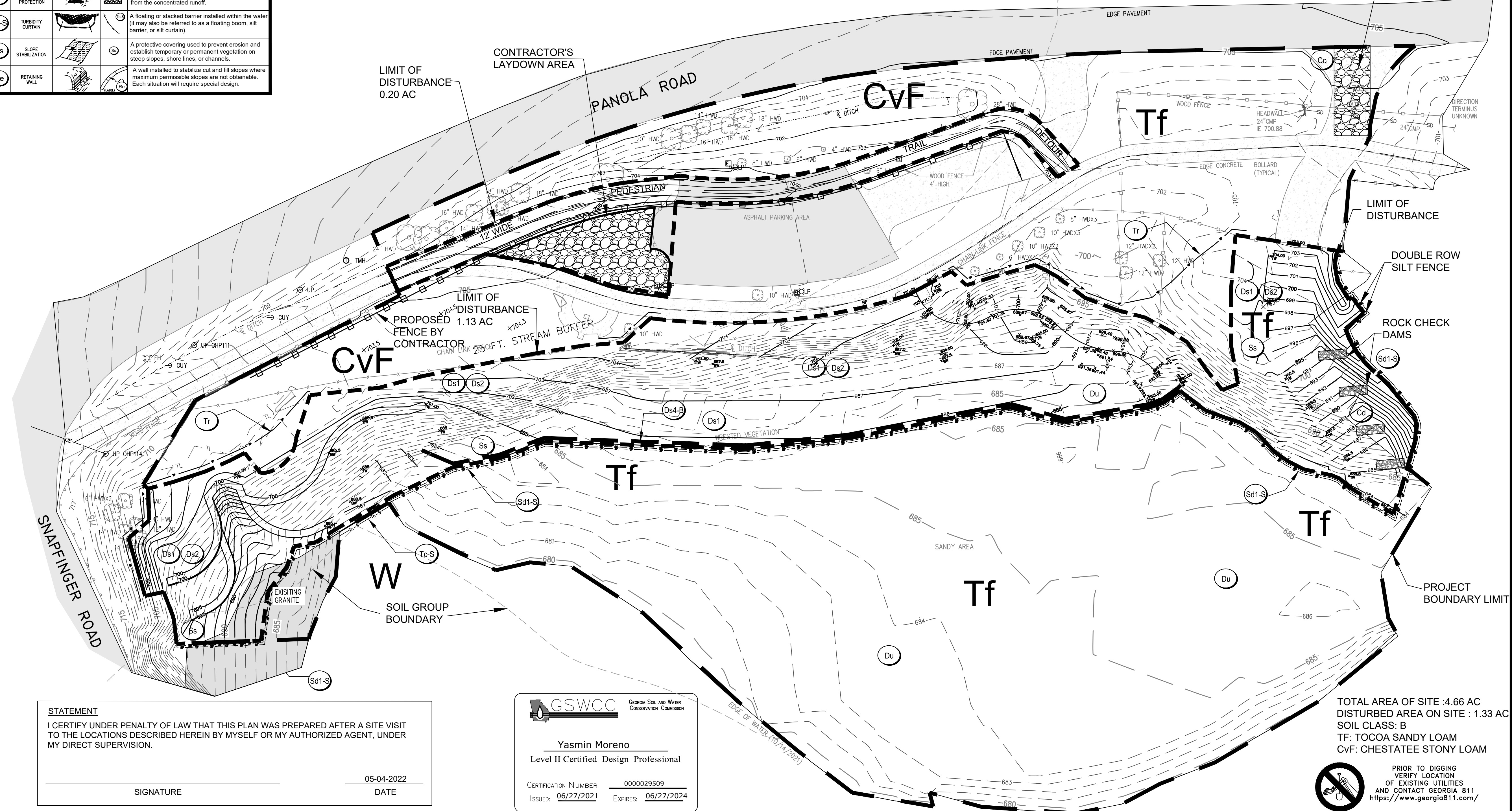

STATEMENT  
I CERTIFY UNDER PENALTY OF LAW THAT THIS PLAN WAS PREPARED AFTER A SITE VISIT TO THE LOCATIONS DESCRIBED HEREIN BY MYSELF OR MY AUTHORIZED AGENT, UNDER MY DIRECT SUPERVISION.

\_\_\_\_\_  
SIGNATURE

05-04-2022  
DATE

**GSWCC** GEORGIA SOIL AND WATER CONSERVATION COMMISSION  
Yasmin Moreno  
Level II Certified Design Professional  
CERTIFICATION NUMBER: 0000029509  
ISSUED: 06/27/2021 EXPIRES: 06/27/2024

TOTAL AREA OF SITE : 4.66 AC  
DISTURBED AREA ON SITE : 1.33 AC  
SOIL CLASS: B  
TF: TOCOA SANDY LOAM  
CvF: CHESTATEE STONY LOAM

PRIOR TO DIGGING  
VERIFY LOCATION  
OF EXISTING UTILITIES  
AND CONTACT GEORGIA 811  
<https://www.georgia811.com/>



CODE	PRACTICE	DETAIL	MAP SYMBOL	DESCRIPTION
Co	CONSTRUCTION EXIT			A crushed stone pad located at the construction site exit to provide a place for removing mud from tires thereby protecting public streets.
Cd	CHECKDAM			A small temporary barrier or dam constructed across a swale, drainage ditch or area of concentrated flow.
Sd1	SEDIMENT BARRIER			A barrier to prevent sediment from leaving the construction site. It may be sandbags, bales of straw or hay, brush, logs and poles, gravel, or a silt fence.
Sd2	INLET SEDIMENT TRAP			An impounding area created by excavating around a storm drain inlet. The excavated area will be filled and stabilized on completion of construction activities.
Sd3	TEMPORARY SEDIMENT BASIN			A basin created by excavation or a dam across a waterway. The surface water runoff is temporarily stored allowing the bulk of the sediment to drop out.
Ds1	DISTURBED AREA STABILIZATION (WITH MULCHING ONLY)			Establishing temporary protection for disturbed areas where seedlings may not have a suitable growing season to produce an erosion retarding cover.
Ds2	DISTURBED AREA STABILIZATION (WITH TEMP SEEDING)			Establishing a temporary vegetative cover with fast growing seedlings on disturbed areas.
Ds3	DISTURBED AREA STABILIZATION (WITH PERM SEEDING)			Establishing a permanent vegetative cover such as trees, shrubs, vines, grasses, or legumes on disturbed areas.
Ds4-B	DISTURBED AREA STABILIZATION (SOODING)			A permanent vegetative cover using sods on highly erodible or critically eroded lands.
Tr	TREE PROTECTION FENCE			To protect desirable trees from injury during construction activity.
St	STORMWATER OUTLET PROTECTION			A paved or short section of riprap channel at the outlet of a storm drain system preventing erosion from the concentrated runoff.
Tc-S	TURBIDITY CURTAIN			A floating or stacked barrier installed within the water (it may also be referred to as a floating boom, silt barrier, or silt curtain).
Ss	SLOPE STABILIZATION			A protective covering used to prevent erosion and establish temporary or permanent vegetation on steep slopes, shore lines, or channels.
Re	RETAINING WALL			A wall installed to stabilize cut and fill slopes where maximum permissible slopes are not obtainable. Each situation will require special design.

**LEGEND**

- PROPOSED PEDESTRIAN TRAIL
- LIMIT OF DISTURBANCE
- EXISTING PAVEMENT
- PROPOSED CONCRETE
- PROPOSED FENCE
- CONTRACTOR'S LAYDOWN AREA
- CONTRACTOR'S SECURE GATE
- PROJECT LIMITS

PRIMARY PERMITTEE:  
CITY OF STONECREST

24-HOUR CONTACT  
DAVID ASBELL  
TEL: 678-283-2938

ENGINEER  
CERM  
1990 LAKESIDE PARKWAY STE 300  
TUCKER, GA 30084  
TEL: 678-999-0173  
CONTACT: YASMIN MORENO, P.E.  
EMAIL: ymoreno@cerm.com  
www.cerm.com

OWNER / DEVELOPER  
CITY OF STONECREST  
3120 STONECREST BLVD.  
STONECREST, GA 30038  
TEL: 770-224-0200  
CONTACT: HARI KARIKARAN  
EMAIL: hkariakaran@stonecrestga.gov  
www.stonecrestga.gov

STATEMENT  
I CERTIFY UNDER PENALTY OF LAW THAT THIS PLAN WAS PREPARED AFTER A SITE VISIT TO THE LOCATIONS DESCRIBED HEREIN BY MYSELF OR MY AUTHORIZED AGENT, UNDER MY DIRECT SUPERVISION.

\_\_\_\_\_  
SIGNATURE

05-04-2022  
DATE

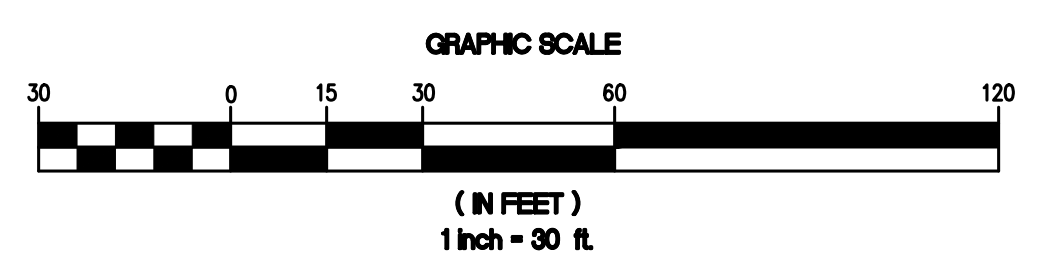

SOIL MAP

CLIENT:  
**STONECREST**  
City of Stonecrest  
3120 Stonecrest Blvd  
Stonecrest, GA 30038  
770-224-0200

REVISIONS

NO.	DATE	DESCRIPTION

**CERM**  
1990 Lakeside Parkway  
Suite 300  
Tucker, GA, 30084  
O: 678.999.0173  
F: 678.999.0186  
[www.cerm.com](http://www.cerm.com)

PROJECT:  
PANOLA SHOALS RIVERBANK STABILIZATION AND RESTORATION PROJECT  
TAX ID: 16 016 03 002  
LAND LOT 17 16th DISTRICT  
CITY OF STONECREST  
DEKALB COUNTY, GEORGIA

DESIGN TEAM

DESIGN BY	CN
DRAWN BY	JD
CHECKED BY	YM

CERM PROJECT NO. 1468A-000A  
CLIENT PROJECT NO. 21-06210-Co018-00

DATE  
JUNE 29, 2022

SHEET TITLE  
**FINAL EROSION CONTROL PLAN**

SHEET No  
**C-08-05**

C:\Project\_Operations\Projects\Active Projects\2021-1468A-000A\_City of Stonecrest South River Stream Bank Restoration\40 - Design Documents\02 Plans\C-08 Erosion Control Plan.dwg Jul 06, 2022 - 5:28pm

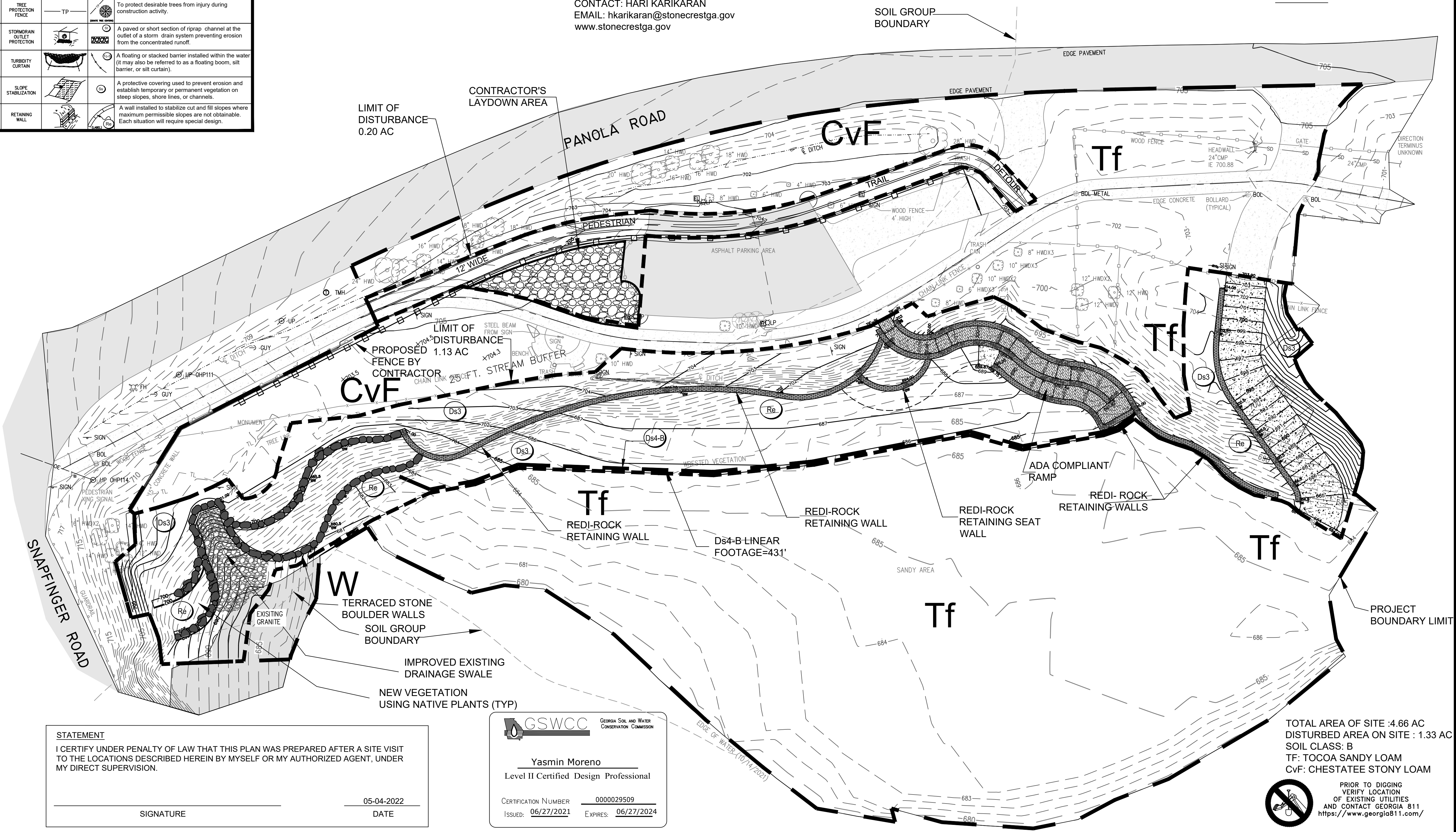

STATEMENT  
I CERTIFY UNDER PENALTY OF LAW THAT THIS PLAN WAS PREPARED AFTER A SITE VISIT TO THE LOCATIONS DESCRIBED HEREIN BY MYSELF OR MY AUTHORIZED AGENT, UNDER MY DIRECT SUPERVISION.

\_\_\_\_\_  
SIGNATURE

05-04-2022  
DATE

Georgia Soil and Water Conservation Commission

Yasmin Moreno  
Level II Certified Design Professional

CERTIFICATION NUMBER 0000029509  
ISSUED: 06/27/2021 EXPIRES: 06/27/2024

⚠️ PRIOR TO DIGGING VERIFY LOCATION OF EXISTING UTILITIES AND CONTACT GEORGIA 811 <https://www.georgia811.com/>

TOTAL AREA OF SITE : 4.66 AC  
DISTURBED AREA ON SITE : 1.33 AC  
SOIL CLASS: B  
TF: TOCOA SANDY LOAM  
CVF: CHESTATEE STONY LOAM

**CRUSHED STONE CONSTRUCTION EXIT**

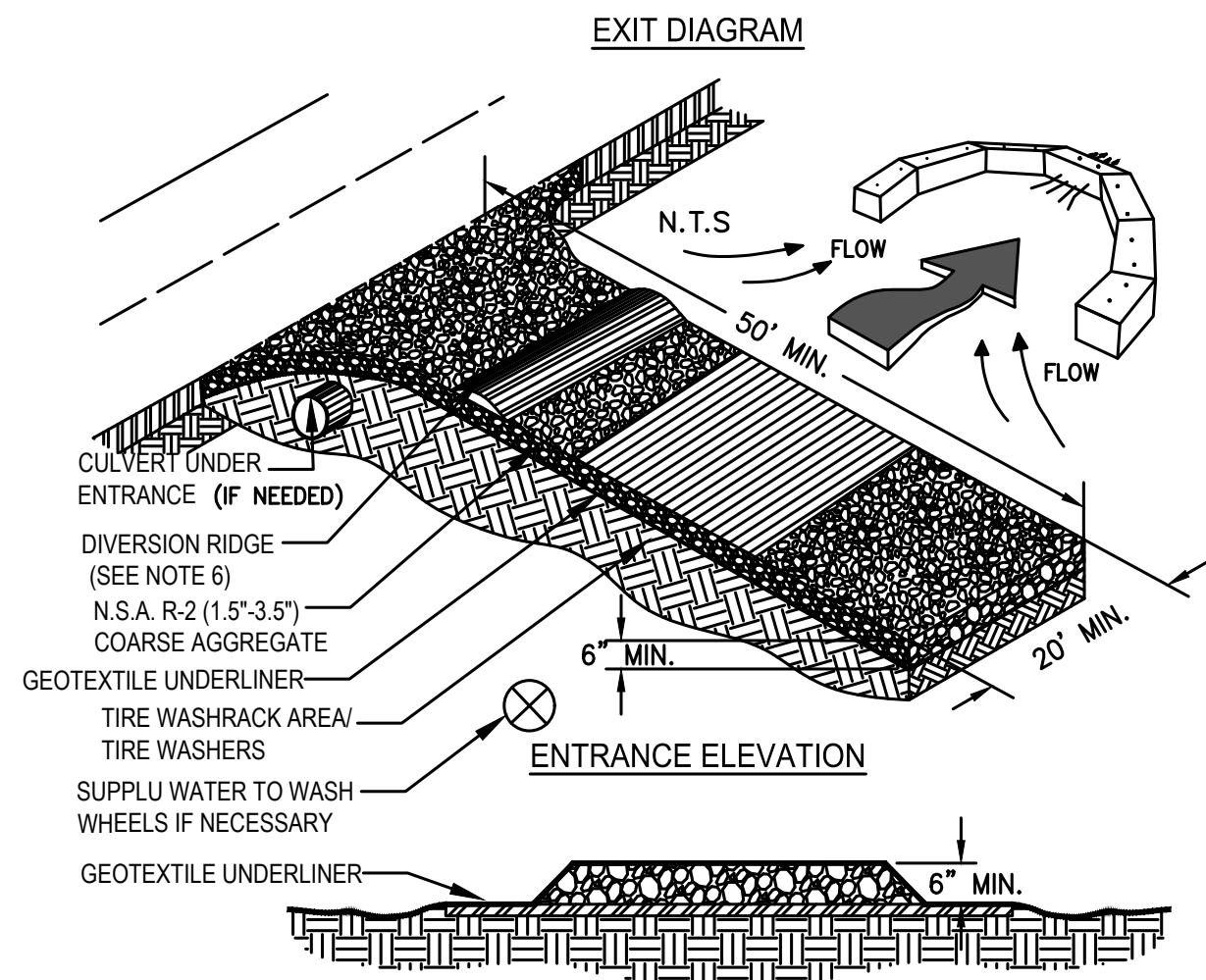

**NOTES:**

1. AVOID LOCATING ON STEEP SLOPES OR AT CURVES ON PUBLIC ROADS.
2. REMOVE ALL VEGETATION AND OTHER UNSUITABLE MATERIAL FROM THE FOUNDATION AREA, GRADE, AND CROWN FOR POSITIVE DRAINAGE.
3. AGGREGATE SIZE SHALL BE IN ACCORDANCE WITH NATIONAL STONE ASSOCIATION R-2 (1.5"-3.5" STONE).
4. GRAVEL PAD SHALL HAVE A MINIMUM THICKNESS OF 6".
5. PAD WIDTH SHALL BE EQUAL FULL WIDTH AT ALL POINTS OF VEHICULAR EGRESS, BUT NO LESS THAN 20'.
6. A DIVERSION RIDGE SHOULD BE CONSTRUCTED WHEN GRADE TOWARD PAVED AREA IS GREATER THAN 2%.
7. INSTALL PIPE UNDER THE ENTRANCE IF NEEDED TO MAINTAIN DRAINAGE DITCHES.
8. WHEN WASHING IS REQUIRED, IT SHOULD BE DONE ON AN AREA STABILIZED WITH CRUSHED STONE THAT DRAINS INTO AN APPROVED SEDIMENT TRAP OR SEDIMENT BASIN (DIVERT ALL SURFACE RUNOFF AND DRAINAGE FROM THE ENTRANCE TO A SEDIMENT CONTROL DEVICE).
9. WASHRACKS AND/OR TIRE WASHERS MAY BE REQUIRED DEPENDING ON SCALE AND CIRCUMSTANCE. IF NECESSARY, WASHRACK DESIGN MAY CONSIST OF ANY MATERIAL SUITABLE FOR TRUCK TRAFFIC THAT REMOVE MUD AND DIRT.
10. MAINTAIN AREA IN A WAY THAT PREVENTS TRACKING AND/OR FLOW OF MUD ONTO PUBLIC RIGHTS-OF-WAYS. THIS MAY REQUIRE TOP DRESSING, REPAIR AND/OR CLEANOUT OF ANY MEASURES USED TO TRAP SEDIMENT.

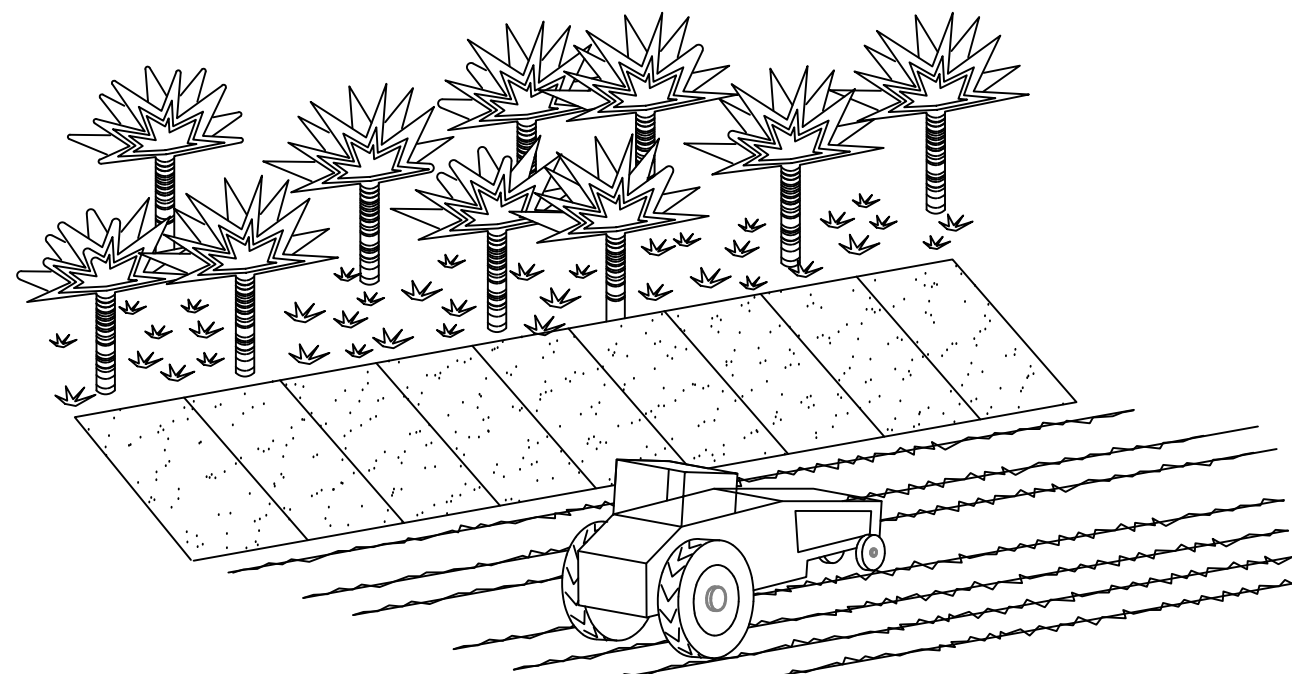

**FILL SLOPE TREATMENT**

EACH LIFT OF THE FILL IS COMPACTED, BUT THE OUTER FACE OF THE SLOPE IS ALLOWED TO REMAIN LOOSE SO THAT THE ROCKS, CLODS, ETC. REACH THE NATURAL OF REPOSE.

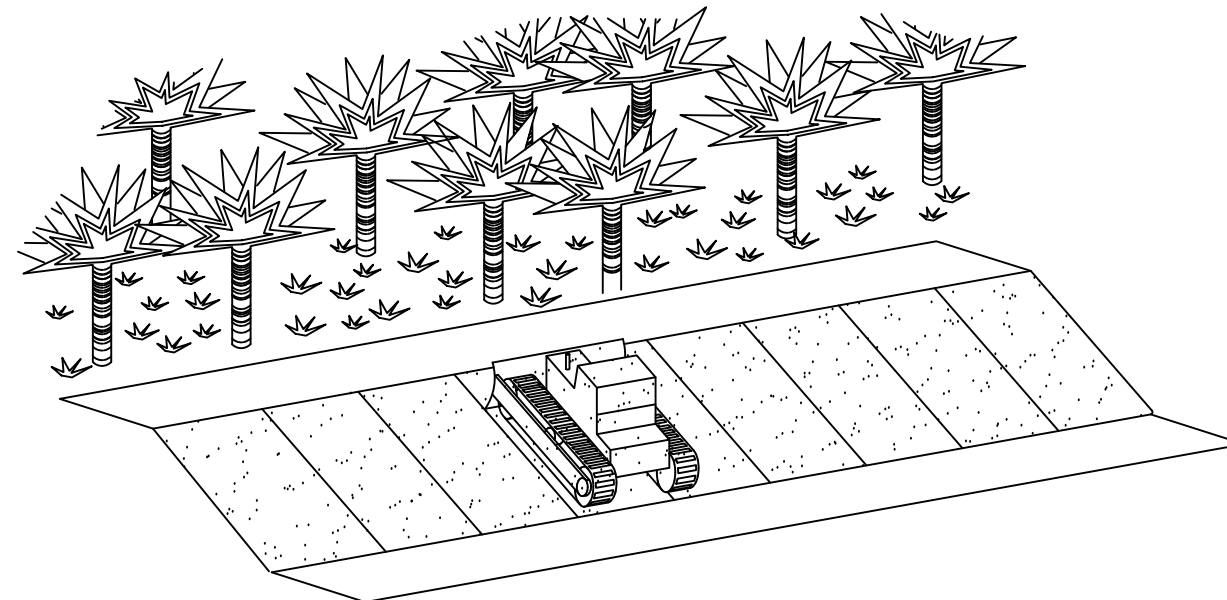

**TRACKING**

DOZER TREADS CREATE GROOVES PERPENDICULAR TO THE SLOPE.

**STONE CHECK DAM**

**CROSS SECTION**

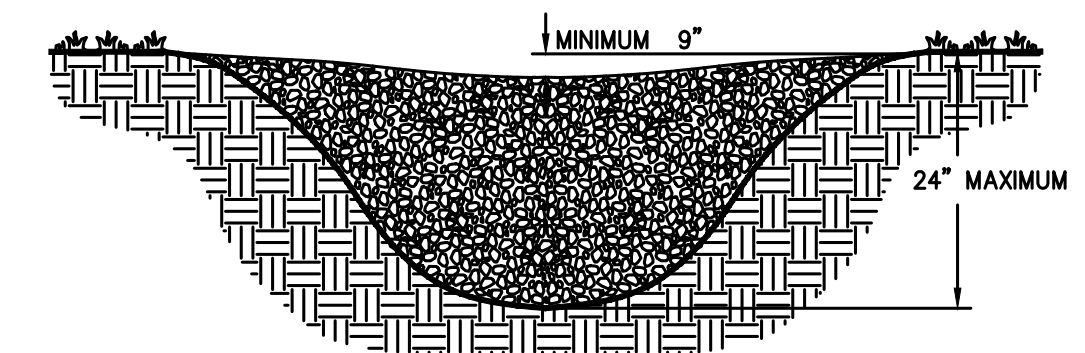

**PROFILE VIEW**

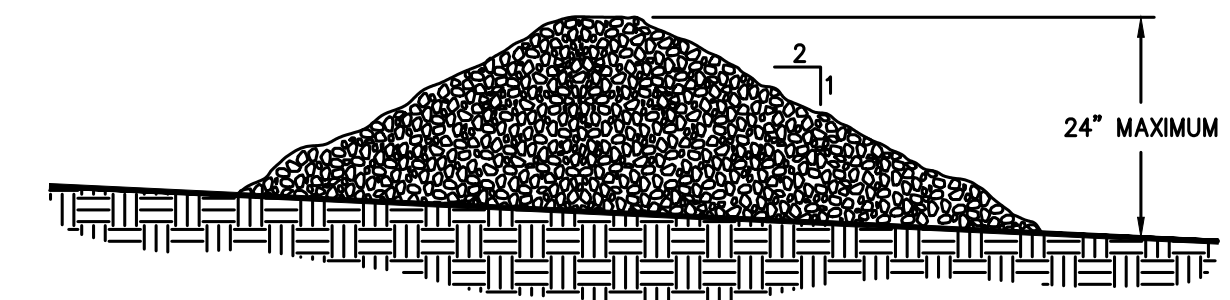

**NOTES:**

1. CHECK DAMS ARE TO BE USED ONLY IN SMALL OPEN CHANNELS (THEY ARE NOT TO BE USED IN LIVE STREAMS).
2. THE DRAINAGE AREA FOR STONE CHECK DAMS SHALL NOT EXCEED TWO ACRES.
3. THE CENTER OF THE CHECK DAM MUST BE AT LEAST 9 INCHES LOWER THAN THE OUTER EDGES.
4. THE DAM HEIGHT SHOULD BE A MAXIMUM OF 2 FEET FROM CENTER TO RIM EDGE.
5. THE SIDE SLOPES OF THE CHECK DAM SHALL NOT EXCEED A 2:1 SLOPE.
6. GEOTEXTILE SHALL BE USED TO PREVENT THE MITIGATION OF SUBGRADE SOIL PARTICLES INTO THE STONES (REFER TO AASHTO M288-96, SECTION 7.3, TABLE 3).

**Co CRUSHED STONE CONSTRUCTION EXIT**  
N.T.S.

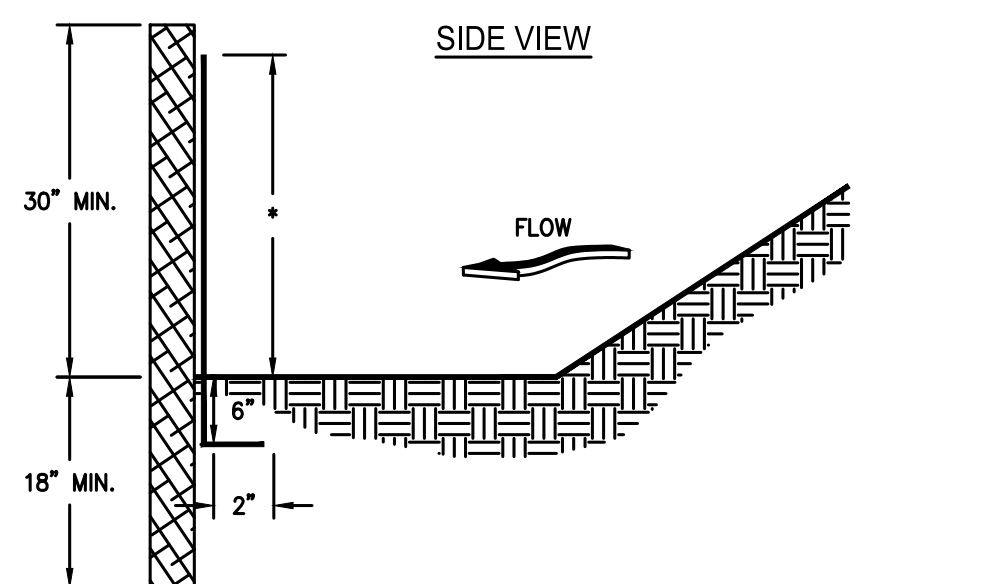

**FRONT VIEW**

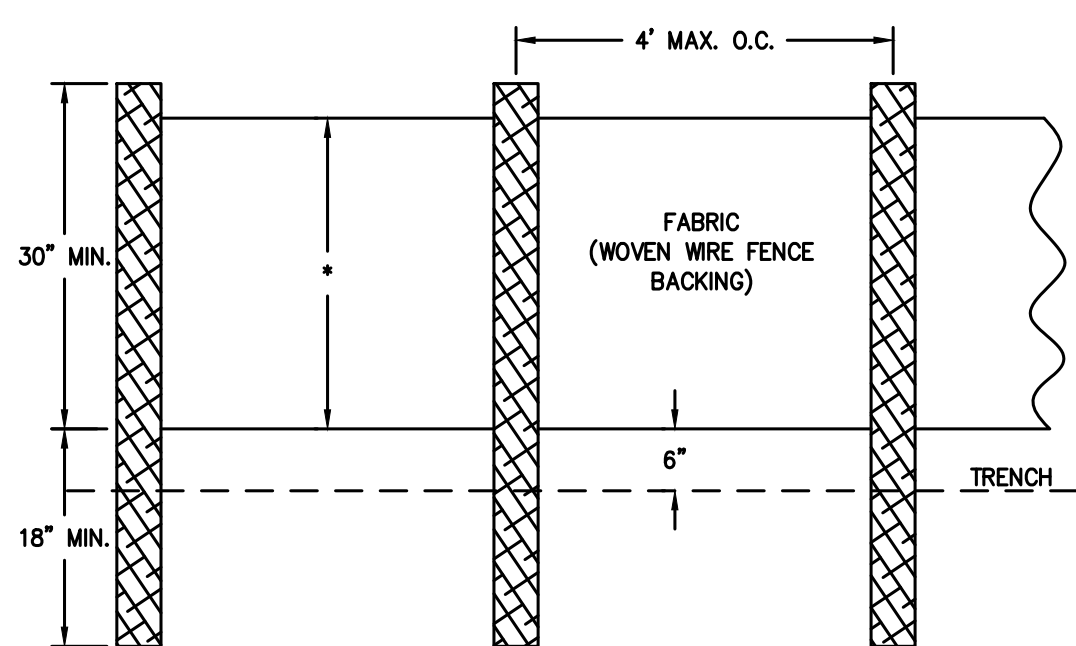

**NOTES:**

1. USE STEEL OR WOOD POSTS OR AS SPECIFIED BY THE EROSION, SEDIMENTATION, AND POLLUTION CONTROL PLAN.
2. HEIGHT (\*) IS TO BE SHOWN ON THE EROSION, SEDIMENTATION, AND POLLUTION CONTROL PLAN.

**Sd1-S SILT FENCE - TYPE SENSITIVE**  
N.T.S.

**Su SURFACE ROUGHENING**  
N.T.S.

**SIDE VIEW**

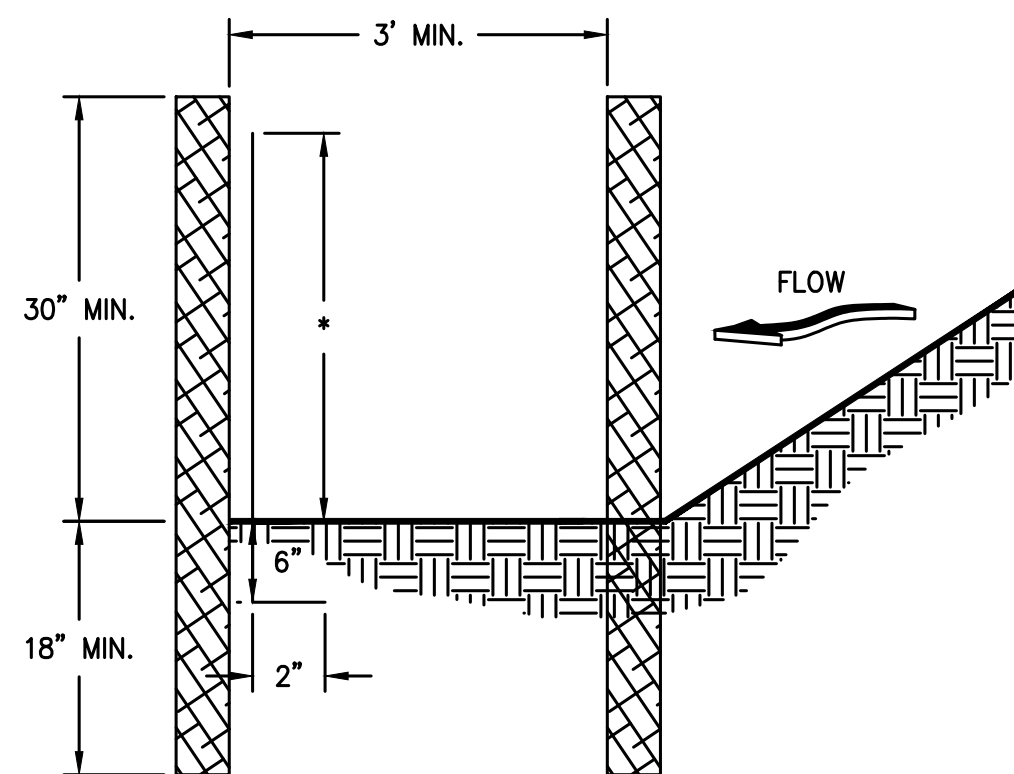

**FRONT VIEW**

**NOTES:**

1. USE STEEL OR WOOD POSTS OR AS SPECIFIED BY THE EROSION, SEDIMENTATION, AND POLLUTION CONTROL PLAN.
2. HEIGHT (\*) IS TO BE SHOWN ON THE EROSION, SEDIMENTATION, AND POLLUTION CONTROL PLAN.

**Sd1-S DOUBLE ROW SILT FENCE**  
N.T.S.

**Cd STONE CHECK DAM**  
N.T.S.

**PLAN**

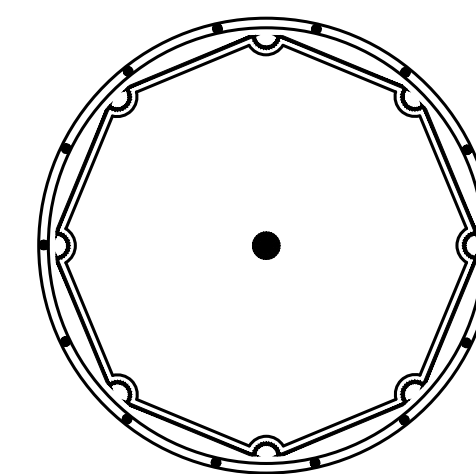

**CROSS-SECTION**

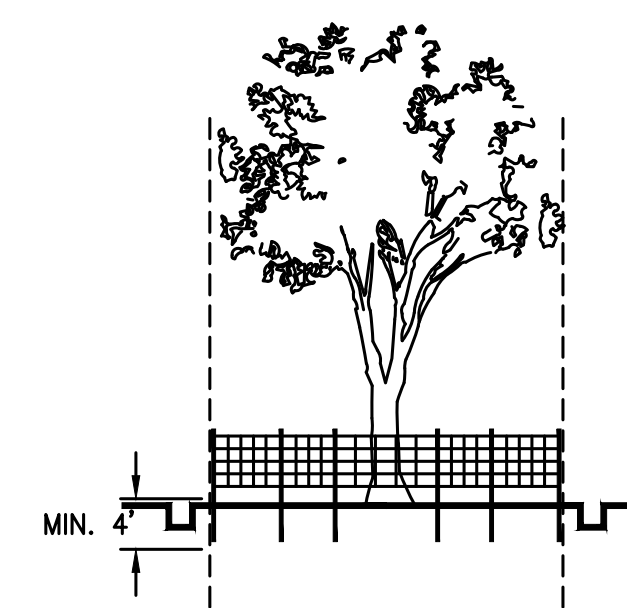

**NOTES:**

1. USE TRENCHER (I.E. DITCH WHICH) TO CUT A 4"-5" W X 18" D TRENCH ALONG DRIP LINE (LIMIT OF CLEARING) AND BACKFILL WITH SAND AND LIGHTLY COMPACT.
2. SPACE STAKES AT INTERVALS SUFFICIENT TO MAINTAIN ALL FENCING OUT OF DRIP LINE OR AS SHOWN BY ENGINEER (SET STAKES NO GREATER THAN 6 FEET ON CENTER-REBAR IS NOT TO BE USED FOR STAKES).
3. MAINTAIN FENCE BY REPAIRING AND/OR REPLACING DAMAGED FENCE. DO NOT REMOVE FENCING PRIOR TO LANDSCAPING OPERATIONS.
4. DO NOT STORE OR STACK MATERIALS, EQUIPMENT, OR VEHICLES WITHIN FENCED AREA.
5. FENCE SHALL BE ORANGE VINYL "SNOW FENCE" 4" HIGH MINIMUM.

**Tr TREE PROTECTION**  
N.T.S.

CLIENT:

**STONECREST**

City of Stonecrest  
3120 Stonecrest Blvd  
Stonecrest, GA 30038  
770-224-0200

REVISIONS		
NO.	DATE	DESCRIPTION

**CERM**

1990 Lakeside Parkway  
Suite 300  
Tucker, GA, 30084  
O: 678.999.0173  
F: 678.999.0186  
[www.cerm.com](http://www.cerm.com)

PROJECT: PANOLA SHOALS RIVERBANK STABILIZATION AND RESTORATION PROJECT  
TAX ID: 16 016 03 002  
LAND LOT 17 16th DISTRICT  
CITY OF STONECREST  
DEKALB COUNTY, GEORGIA

DESIGN TEAM	
DESIGN BY	CN
DRAWN BY	JD
CHECKED BY	YM

CERM PROJECT NO. 1468A-000A  
CLIENT PROJECT NO. 21-06210-Co018-00

**DATE**  
JUNE 29, 2022

**SHEET TITLE**  
EROSION CONTROL DETAILS

**SHEET No**  
C-08-06

Georgia Soil and Water Conservation Commission

**Yasmin Moreno**  
Level II Certified Design Professional

CERTIFICATION NUMBER: 0000029509  
ISSUED: 06/27/2021 EXPIRES: 06/27/2024

PRIOR TO DIGGING  
VERIFY LOCATION  
OF EXISTING UTILITIES  
AND CONTACT GEORGIA 811  
<https://www.georgia811.com/>

G:\Project Operations\Projects\Active Projects\2021-1468A-000A City of Stonecrest South River Stream Bank Restoration\0 - Design Documents\02 Plans\C-08 Erosion Control Plan.dwg Jul 06, 2022 - 5:28pm

Du

### DUST CONTROL ON DISTURBED AREAS

#### DEFINITION

Controlling surface and air movement of dust on land-disturbing activities.



#### PURPOSE

- Prevent the movement of dust from exposed soil surfaces.
- Prevent the movement of airborne substances that may be harmful to health.

#### INSTALLATION

- Apply according to approved plan, if shown.
- Mulch disturbed areas and tackify with resins such as asphalt, Curasol or Terratack according to manufacturer's recommendations.
- Stabilize disturbed areas with temporary or permanent vegetation.
- Irrigate disturbed areas until surface is wet.
- Cover surfaces with crushed stone or gravel.

Du

- Apply calcium chloride at a rate to keep surfaces moist.
- Apply spray-on adhesives to mineral soils (not muck soils) as described in Table 1.

Table 1. Spray-On Adhesive Application Requirements

Adhesive	Water Dilution	Nozzle Type	Application (Gal./Acre)
Anionic asphalt emulsion	7:1*	Coarse spray	1,200
Latex emulsion	12.5:1 *	Fine spray	235
Resin-in-water emulsion	4:1*	Fine spray	300

\*Use manufacturer's recommendations when available.

#### MAINTENANCE

- Prohibit traffic on surface after spraying.
- Supplement surface covering as needed.

#### REFERENCES

- Ds1** Disturbed Area Stabilization (With mulching only)
- Ds2** Disturbed Area Stabilization (With temporary seeding)
- Ds3** Disturbed Area Stabilization (With permanent seeding)
- Ds4** Disturbed Area Stabilization (With sodding)
- Tb** Tackifiers and Binders

Du DUST CONTROL ON DISTURBED AREAS  
N.T.S.

### TEMPORARY SEDIMENT TRAP

COURTESY OF CITY OF KNOXVILLE BMP EROSION AND SEDIMENT

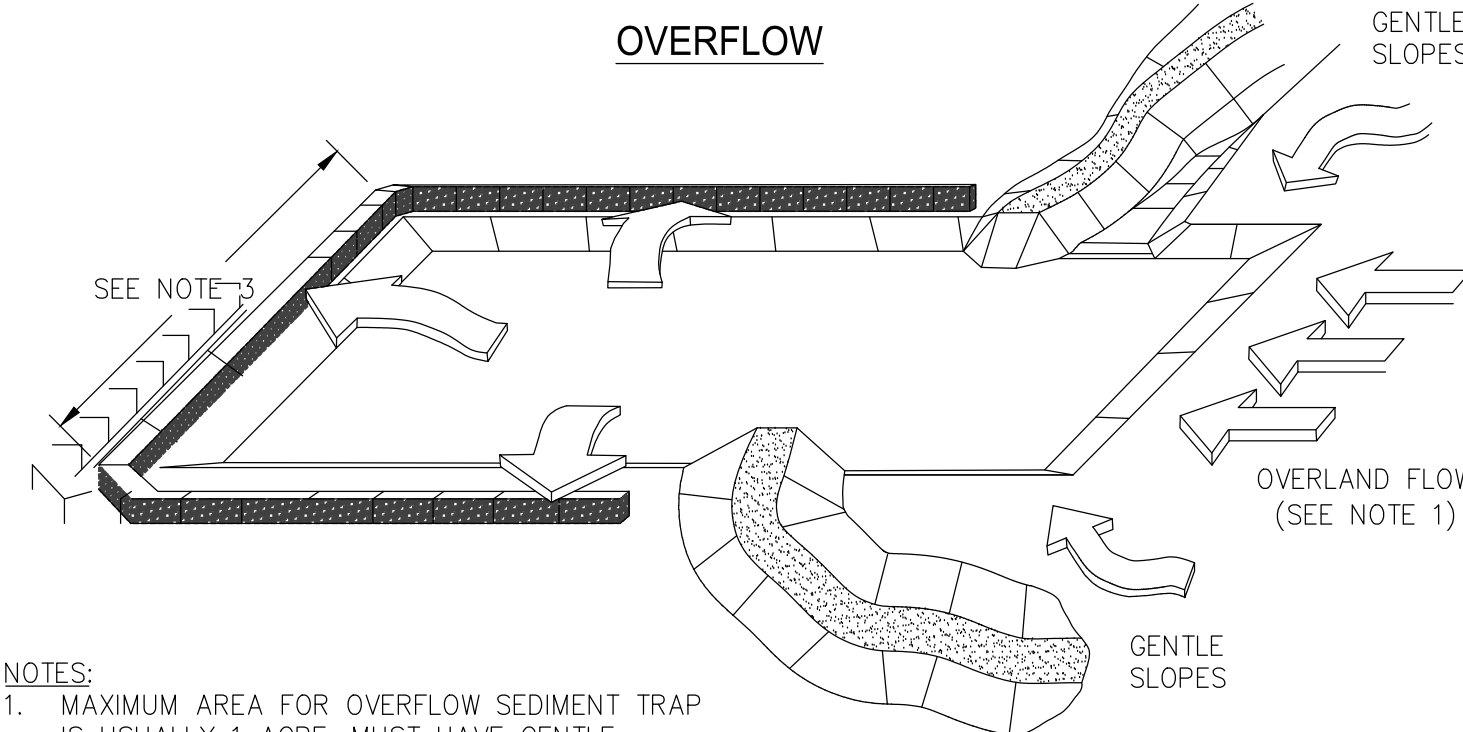

- NOTES:
- MAXIMUM AREA FOR OVERFLOW SEDIMENT TRAP IS USUALLY 1 ACRE. MUST HAVE GENTLE SLOPES (LESS THAN 2% GRADUALLY) AND PREDOMINATELY OVERLAND SHEET FLOW.
  - MAXIMUM PERMANENT WET DEPTH IS 2 FEET. OVERFLOW SEDIMENT TRAPS MAY NOT BE EFFECTIVE FOR HIGH GROUNDWATER TABLE AND INFLOWS.
  - USE THE MOST PERMEABLE SEDIMENT CONTROL IN LABELED AREA SO AS TO MAXIMIZE TRAVEL TIME AND SETTLING OF SEDIMENT.

Sd4-B TEMPORARY SEDIMENT TRAP  
N.T.S.

### TURBIDITY CURTAIN SYSTEM

ANCHOR SYSTEM AND LAYOUT DETAILS

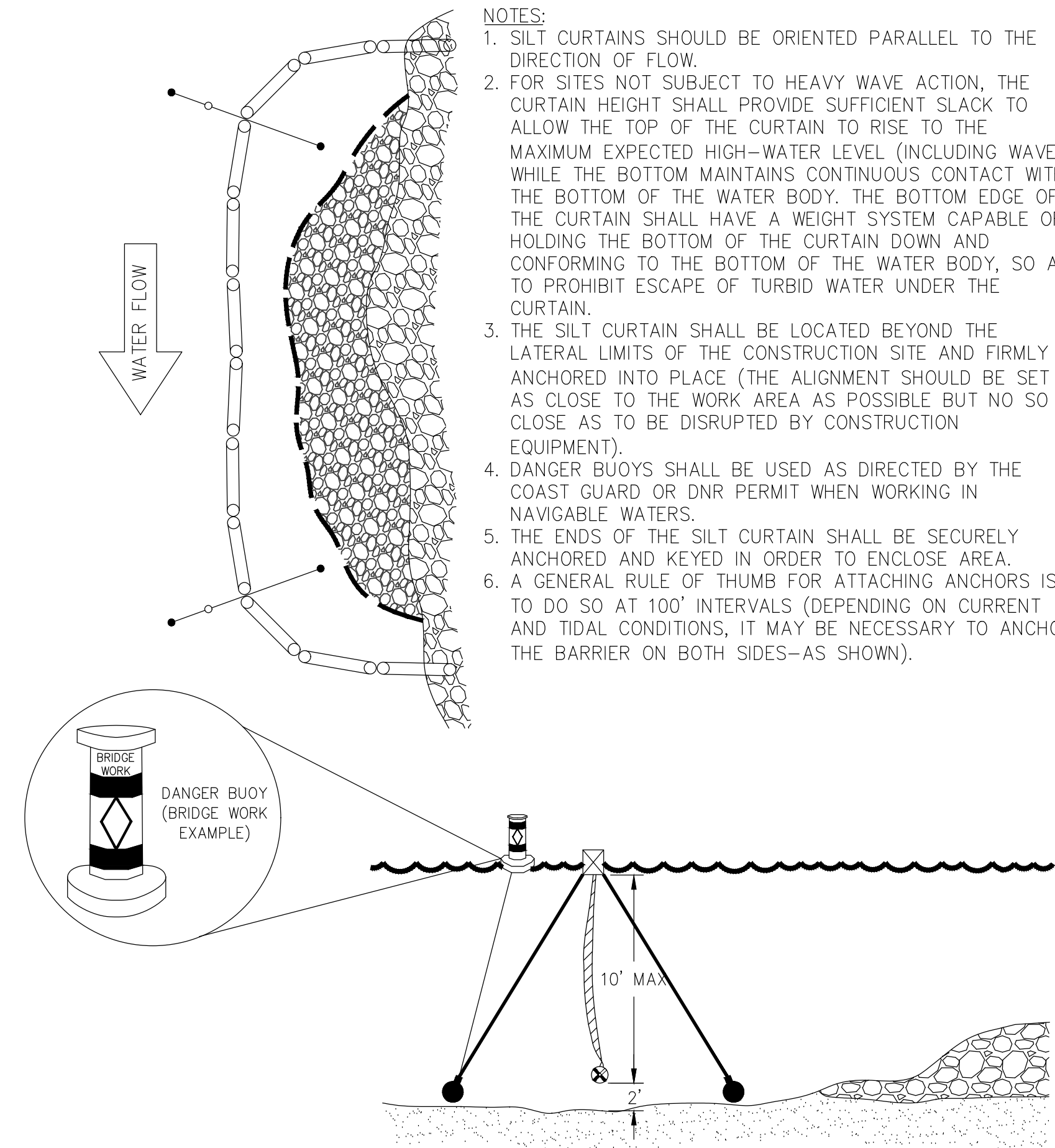

- NOTES:
- SILT CURTAINS SHOULD BE ORIENTED PARALLEL TO THE DIRECTION OF FLOW.
  - FOR SITES NOT SUBJECT TO HEAVY WAVE ACTION, THE CURTAIN HEIGHT SHALL PROVIDE SUFFICIENT SLACK TO ALLOW THE TOP OF THE CURTAIN TO RISE TO THE MAXIMUM EXPECTED HIGH-WATER LEVEL (INCLUDING WAVES) WHILE THE BOTTOM MAINTAINS CONTINUOUS CONTACT WITH THE BOTTOM OF THE WATER BODY. THE BOTTOM EDGE OF THE CURTAIN SHALL HAVE A WEIGHT SYSTEM CAPABLE OF HOLDING THE BOTTOM OF THE CURTAIN DOWN AND CONFORMING TO THE BOTTOM OF THE WATER BODY, SO AS TO PROHIBIT ESCAPE OF TURBID WATER UNDER THE CURTAIN.
  - THE SILT CURTAIN SHALL BE LOCATED BEYOND THE LATERAL LIMITS OF THE CONSTRUCTION SITE AND FIRMLY ANCHORED INTO PLACE (THE ALIGNMENT SHOULD BE SET AS CLOSE TO THE WORK AREA AS POSSIBLE BUT NO SO CLOSE AS TO BE DISRUPTED BY CONSTRUCTION EQUIPMENT).
  - DANGER BUOYS SHALL BE USED AS DIRECTED BY THE COAST GUARD OR DNR PERMIT WHEN WORKING IN NAVIGABLE WATERS.
  - THE ENDS OF THE SILT CURTAIN SHALL BE SECURELY ANCHORED AND KEYED IN ORDER TO ENCLOSE AREA.
  - A GENERAL RULE OF THUMB FOR ATTACHING ANCHORS IS TO DO SO AT 100' INTERVALS (DEPENDING ON CURRENT AND TIDAL CONDITIONS, IT MAY BE NECESSARY TO ANCHOR THE BARRIER ON BOTH SIDES-AS SHOWN).

Tc-S TURBIDITY CURTAIN  
N.T.S.

### ROCK FILTER DAM

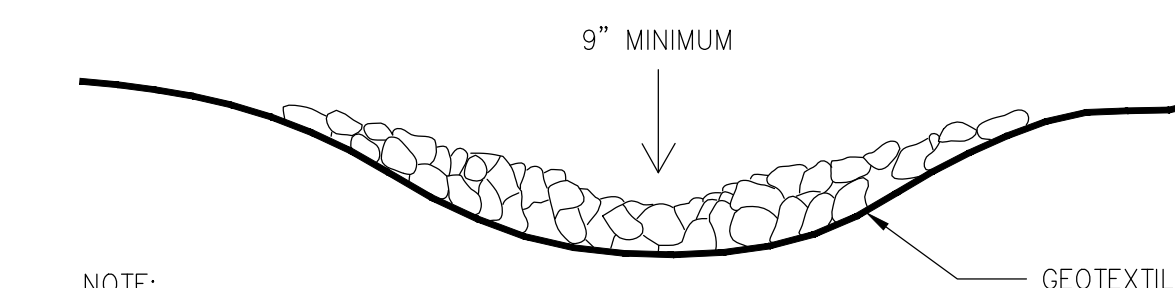

NOTE:  
ROCK FILTER DAM IS TO BE CLEANED OUT WHEN VOLUME BECOMES HALF FULL.

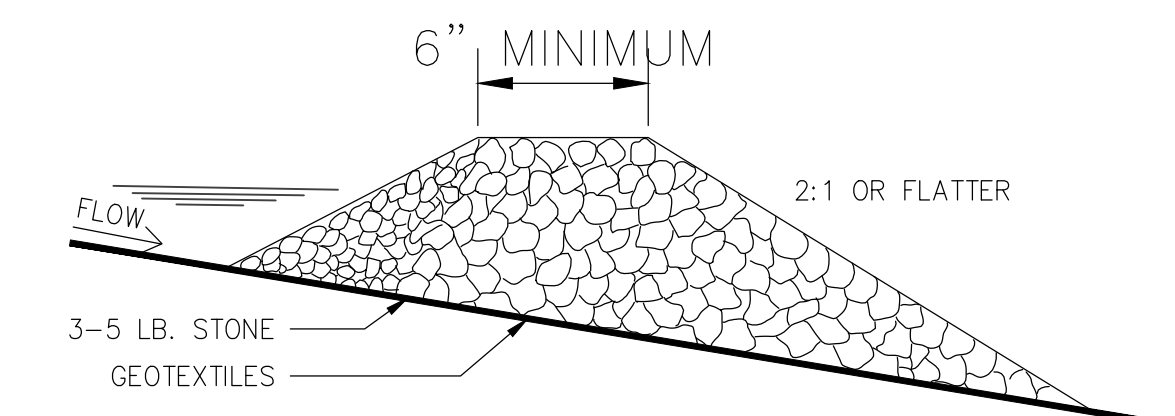

NOTE:  
ROCK SIZE DETERMINED ACCORDING TO SPECIFICATIONS SET FORTH IN APPENDIX C.

Rd ROCK FILTER DAM  
N.T.S.

**GSWCC** GEORGIA SOIL AND WATER CONSERVATION COMMISSION

**Yasmin Moreno**  
Level II Certified Design Professional

CERTIFICATION NUMBER: 0000029509  
ISSUED: 06/27/2021 EXPIRES: 06/27/2024

PRIOR TO DIGGING VERIFY LOCATION OF EXISTING UTILITIES AND CONTACT GEORGIA 811 <https://www.georgia811.com/>

CLIENT:

**STONECREST**

City of Stonecrest  
3120 Stonecrest Blvd  
Stonecrest, GA 30083  
770-224-0200

REVISIONS		
NO.	DATE	DESCRIPTION

**C.E.R.M.**

1990 Lakeside Parkway  
Suite 300  
Tucker, GA, 30084  
O: 678.999.0173  
F: 678.999.0186  
[www.cerm.com](http://www.cerm.com)

PROJECT:

PANOLA SHOALS RIVERBANK STABILIZATION AND RESTORATION PROJECT  
TAX ID: 16 016 03 002  
LAND LOT 17 16th DISTRICT  
CITY OF STONECREST  
DEKALB COUNTY, GEORGIA

DESIGN TEAM

DESIGN BY	CN
DRAWN BY	JD
CHECKED BY	YM

CERM PROJECT NO. 1468A-000A  
CLIENT PROJECT NO. 21-06210-Co018-00

DATE: JUNE 29, 2022

SHEET TITLE: **EROSION CONTROL DETAILS**

SHEET No: **C-08-07**

G:\Project\_Operations\Projects\Active Projects\2021-1468A-000A City of Stonecrest South River Stream Bank Restoration\40 - Design Documents\02 Plans\C-08 Erosion Control Plan.dwg Jul 06, 2022 - 5:28pm

Ds3

DISTURBED AREA STABILIZATION (WITH PERMANENT SEEDING)

DEFINITION

THE PLANTING OF PERENNIAL VEGETATION SUCH AS TREES, SHRUBS, VINES, GRASSES, OR LEGUMES ON EXPOSED AREAS FOR FINAL PERMANENT STABILIZATION. PERMANENT PERENNIAL VEGETATION SHALL BE USED TO ACHIEVE FINAL STABILIZATION.

CONDITIONS

PERMANENT PERENNIAL VEGETATION IS USED TO PROVIDE A PROTECTIVE COVER FOR EXPOSED AREAS INCLUDING CUTS, FILLS, DAMS, AND OTHER DENUDED AREAS.

SPECIFICATIONS

GRADING AND SHAPING

GRADING AND SHAPING MAY NOT BE REQUIRED WHERE HYDRAULIC SEEDING AND FERTILIZING EQUIPMENT IS TO BE USED. VERTICAL BANKS SHALL BE SLOPED TO ENABLE PLANT ESTABLISHMENT WHEN CONVENTIONAL SEEDING AND FERTILIZING ARE TO BE DONE...

CONCENTRATIONS OF WATER THAT WILL CAUSE EXCESSIVE SOIL EROSION SHALL BE DIVERTED TO A SAFE OUTLET. DIVERSIONS AND OTHER TREATMENT PRACTICES SHALL CONFORM WITH THE APPROPRIATE STANDARDS AND SPECIFICATIONS.

SEEDBED PREPARATION

SEEDBED PREPARATION MAY NOT BE REQUIRED WHERE HYDRAULIC SEEDING AND FERTILIZING EQUIPMENT IS TO BE USED. WHEN CONVENTIONAL SEEDING IS TO BE USED, SEEDBED PREPARATION WILL BE DONE AS FOLLOWS:

BROADCAST PLANTINGS

- 1. TILLAGE AT A MINIMUM, SHALL ADEQUATELY LOOSEN THE SOIL TO A DEPTH OF 4 TO 6 INCHES; ALLEVIATE COMPACTION; INCORPORATE LIME AND FERTILIZER. SMOOTH AND FIRM THE SOIL. ALLOW FOR THE PROPER PLACEMENT OF SEED, SPRIGS, OR PLANTS; AND ALLOW FOR THE ANCHORING OF STRAW OR HAY MULCH IF A DISK IS TO BE USED.

INDIVIDUAL PLANTS

- 1. WHERE INDIVIDUAL PLANTS ARE TO BE SET, THE SOIL SHALL BE PREPARED BY EXCAVATING HOLES, OPENING FURROWS, OR DIBBLE PLANTING.

PLANTING

HYDRAULIC SEEDING

MIX THE SEED (INOCULATED IF NEEDED), FERTILIZER, AND WOOD CELLULOSE OR WOOD PULP FIBER MULCH WITH WATER AND APPLY IN A SLURRY UNIFORMLY OVER THE AREA TO BE TREATED.

CONVENTIONAL SEEDING

SEEDING WILL BE DONE ON A FRESHLY PREPARED AND FIRMED SEEDBED. FOR BROADCAST PLANTING, USE A CULTIPACKER SEEDER, DRILL, ROTARY SEEDER, OTHER MECHANICAL SEEDER, OR HAND SEEDING TO DISTRIBUTE THE SEED UNIFORMLY OVER THE AREA TO BE TREATED...

NO-TILL SEEDING

NO-TILL SEEDING IS PERMISSIBLE INTO ANNUAL COVER CROPS WHEN PLANTING IS DONE FOLLOWING MATURITY OF THE COVER CROP OR IF THE TEMPORARY COVER STAND IS SPARSE ENOUGH TO ALLOW ADEQUATE GROWTH OF THE PERMANENT (PERENNIAL) SPECIES.

INDIVIDUAL PLANTS

SHRUBS, VINES AND SPRIGS MAY BE PLANTED WITH APPROPRIATE PLANTERS OR HAND TOOLS. PINE TREES SHALL BE PLANTED MANUALLY IN THE SUBSOIL FURROW. EACH PLANT SHALL BE SET IN A MANNER THAT WILL AVOID CROWDING THE ROOTS.

MULCHING

MULCH IS REQUIRED FOR ALL PERMANENT VEGETATION APPLICATIONS. MULCH APPLIED TO SEEDED AREAS SHALL ACHIEVE 75% SOIL COVER. SELECT THE MULCHING MATERIAL FROM THE FOLLOWING AND APPLY AS INDICATED:

- 1. DRY STRAW OR DRY HAY OF GOOD QUALITY AND FREE OF WEED SEEDS CAN BE USED. DRY STRAW SHALL BE APPLIED AT THE RATE OF 2 TONS PER ACRE.

APPLYING MULCH

STRAW OR HAY MULCH WILL BE SPREAD UNIFORMLY WITHIN 24 HOURS AFTER SEEDING AND/OR PLANTING. THE MULCH MAY BE SPREAD BY BLOWER-TYPE SPREADING EQUIPMENT, OTHER SPREADING EQUIPMENT OR BY HAND.

ANCHORING MULCH

ANCHOR STRAW OR HAY MULCH IMMEDIATELY AFTER APPLICATION BY ONE OF THE FOLLOWING METHODS: 1. EMULSIFIED ASPHALT CAN BE (A) SPRAYED UNIFORMLY ONTO THE MULCH AS IT IS EJECTED FROM THE BLOWER MACHINE OR (B) SPRAYED ON THE MULCH IMMEDIATELY FOLLOWING MULCH APPLICATION WHEN STRAW OR HAY IS SPREAD BY METHODS OTHER THAN SPECIAL BLOWER EQUIPMENT.

THE COMBINATION OF ASPHALT EMULSION AND WATER SHALL CONSIST OF A HOMOGENEOUS MIXTURE SATISFACTORY FOR SPRAYING. THE MIXTURE SHALL CONSIST OF 100 GALLONS OF GRADE SS-1H OR CSS-1H EMULSIFIED ASPHALT AND 100 GALLONS OF WATER PER TON OF MULCH.

CARE SHALL BE TAKEN AT ALL TIMES TO PROTECT STATE WATERS, THE PUBLIC, ADJACENT PROPERTY, PAVEMENTS, CURBS, SIDEWALKS, AND ALL OTHER STRUCTURES FROM ASPHALT DISCOLORATION.

2. HAY AND STRAW MULCH SHALL BE PRESSED INTO THE SOIL IMMEDIATELY AFTER THE MULCH IS SPREAD. A SPECIAL "PACKER DISK" OR DISK HARROW WITH THE DISKS SET STRAIGHT MAY BE USED. THE DISKS MAY BE SMOOTH OR SERRATED AND SHOULD BE 20 INCHES OR MORE IN DIAMETER AND 8 TO 12 INCHES APART.

3. SYNTHETIC TACKIFIERS OR BINDERS APPROVED BY GDOT SHALL BE APPLIED IN CONJUNCTION WITH OR IMMEDIATELY AFTER THE MULCH IS SPREAD. SYNTHETIC TACKIFIERS SHALL BE MIXED AND APPLIED ACCORDING TO MANUFACTURER'S SPECIFICATIONS.

4. RYE OR WHEAT CAN BE INCLUDED WITH FALL AND WINTER PLANTINGS TO STABILIZE THE MULCH. THEY SHALL BE APPLIED AT A RATE OF ONE-QUARTER TO ONE HALF BUSHEL PER ACRE.

IRRIGATION

IRRIGATION SHALL BE APPLIED AT A RATE THAT WILL NOT CAUSE RUNOFF.

Note

- 1. Permanent seeding, per table, to only be used in acres where permanent vegetation is not specified on landscape plan

SEEDING RATES FOR PERMANENT SEEDING

Table with columns: SPECIES, RATE PER ACRE, RATE PER 1,000 SF, PLANTING DATES BY REGION (M-L, P, C), REMARKS. Lists various species like Bahia, Bermuda, Fescue, etc.

- 1. RATES ARE FOR BROADCASTED SEED. IF A SEED DRILL IS USED, REDUCE THE RATES BY ON-HALF.

Ds2

DISTURBED AREA STABILIZATION (WITH TEMPORARY SEEDING)

GENERAL

THIS VEGETATIVE PLAN WILL BE CARRIED OUT ON ROADS CUT AND FILL SLOPES SHOULDERS AND OTHER CRITICAL AREAS CREATED BY CONSTRUCTION SEEDING WILL BE DONE AS SOON AS CONSTRUCTION IN AN AREA IS COMPLETED...

SOIL CONDITIONS

DUE TO GRADING AND CONSTRUCTION THE AREAS TO BE TREATED ARE MAINLY SUBSOIL AND SUBSTRATA FERTILITY IS LOW AND THE PHYSICAL CHARACTERISTICS OF THE EXPOSED MATERIAL ARE UNFAVORABLE TO ALL BUT THE MOST HARDY PLANTS.

TREATMENT SPECIFICATIONS

CONVENTIONAL SEEDING EQUIPMENT

GRADE SHAPE AND SMOOTH WHERE NEEDED TO PROVIDE FOR SAFE EQUIPMENT OPERATION AT SEEDING TIME AND FOR MAINTENANCE PURPOSES THE TIME AND FERTILIZER IN DRY FORM WILL BE SPREAD UNIFORMLY OVER THE AREA IMMEDIATELY BEFORE SEEDBED PREPARATION...

- A. A SEEDING WITH MULCH: CONVENTIONAL SEEDING EQUIPMENT ON SLOPES LESS THAN 3:1

AGRICULTURAL LIMESTONE 4000 LBS./ACRE
FERTILIZER 5-10-15 1500 LBS./ACRE
MULCH, STRAW OR HAY 5000 LBS./ACRE

Table with columns: SEED SPECIES, RATE/ACRE, PLANTING DATES. Lists Weeping Lovegrass, Sudan Grass, Brown Top Millet.

- B. TOPDRESSING: APPLY WHEN PLANTS ARE 2 TO 4 INCHES TALL. FERTILIZER (AMMONIUM NITRATE 33:5%) 300 LBS./ACRE

DISTURBED AREA STABILIZATION

Ds2

N.T.S.

Ds1

DISTURBED AREA STABILIZATION (WITH MULCHING ONLY)

A TEMPORARY COVER OVER BASE AREA TO PREVENT EROSION AND REDUCE RUNOFF

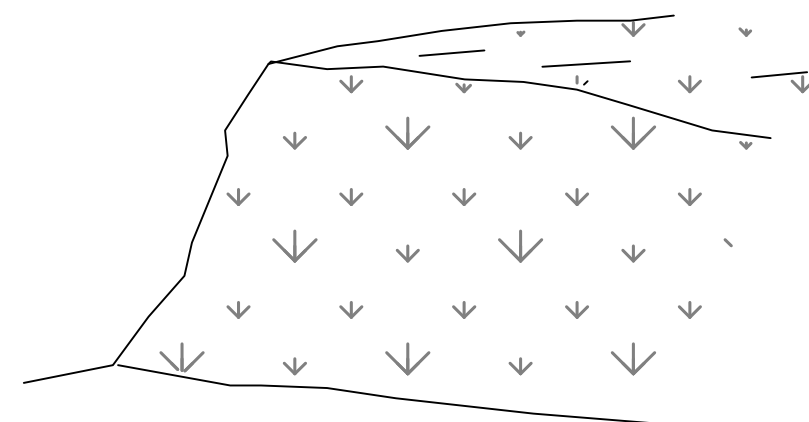

6 MONTHS OR WHEN SEEDING DOES NOT HAVE A SUITABLE GROWING SEASON

MATERIALS AND RATES:

Table with columns: MATERIAL, RATE. Lists Straw or Hay, Wood Waste, Chips, Sawdust or Bark, Matting or Netting, Cutback Asphalt, Polyethylene Film.

DISTURBED AREA STABILIZATION

Ds1

N.T.S.

CLIENT:



City of Stonecrest
3120 Stonecrest Blvd
Stonecrest, GA 30038
770-224-0200

REVISIONS

Table with columns: NO., DATE, DESCRIPTION. Empty rows for revisions.



1990 Lakeside Parkway
Suite 300
Tucker, GA, 30084
O: 678.999.0173
F: 678.999.0186
www.cerm.com

PANOLA SHOALS RIVERBANK STABILIZATION AND RESTORATION PROJECT
TAX ID: 16 016 03 002
LAND LOT 17 16th DISTRICT
CITY OF STONECREST
DEKALB COUNTY, GEORGIA

DESIGN TEAM table with columns: DESIGN BY, DRAWN BY, CHECKED BY. Lists CN, JM, YM.

CERM PROJECT NO. 1468A-000A
CLIENT PROJECT NO. 21-06210-Co018-00

DATE: JUNE 29, 2022
SHEET TITLE: EROSION CONTROL DETAILS

SHEET No: C-08-08

GSWCC logo and signature of Yasmin Moreno, Level II Certified Design Professional. Includes certification number and dates.

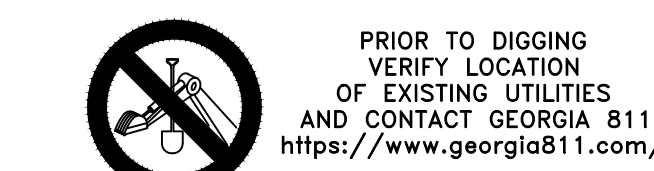

G:\Project\_Operations\Projects\Active Projects\2021-1468A-000A City of Stonecrest South River Stream Bank Restoration\0 - Design Documents\02 Plans\C-08 Erosion Control Plan.dwg Jul 06, 2022 - 5:28pm

**Ss** SLOPE STABILIZATION



**DEFINITION**  
A PROTECTIVE COVERING USED TO PREVENT EROSION AND ESTABLISH TEMPORARY OR PERMANENT VEGETATION ON STEEP SLOPES, SHORE LINES, OR CHANNELS

**PURPOSE**  
TO PROVIDE A COVER LAYER THAT STABILIZES THE SOIL AND ACT AS A RAIN DROP IMPACT DISSIPATER WHILE PROVIDING A MICROCLIMATE THAT PROTECTS YOUNG VEGETATION AND PROMOTES ITS ESTABLISHMENT. IF USING SLOPE STABILIZATION TO REINFORCE CHANNELS, PLEASE REFER TO SPECIFICATION.

**Ch-Channel Stabilization.**

**CONDITIONS**  
SLOPE STABILIZATION CAN BE APPLIED TO FLAT AREAS OR SLOPES WHERE THE EROSION HAZARD IS HIGH AND SLOPE PROTECTION IS NEEDED DURING THE ESTABLISHMENT OF VEGETATION.

**PLANNING CONSIDERATIONS**  
CARE MUST BE TAKEN TO CHOOSE THE TYPE OF SLOPE STABILIZATION PRODUCT THE IS MOST APPROPRIATE FOR THE SPECIFIC NEEDS OF A PROJECT. TWO GENERAL TYPES OF SLOPE STABILIZATION PRODUCTS ARE DISCUSSED WITHIN THIS SPECIFICATION

**Rolled Erosion Control Products (RECP)**  
A NATURAL FIBER BLANKET WITH SINGLE OR DOUBLE PHOTODEGRADABLE NETS.

**Hydraulic Erosion Control Products (HECP)**  
HECP SHALL UTILIZE STRAW, COTTON, WOOD OR OTHER NATURAL BASED FIBERS HELD TOGETHER BY A SOIL BINDING AGENT THAT WORKS TO STABILIZE SOIL PARTICLES PAPER MUCH SHOULD NOT BE USED FOR EROSION CONTROL.

**CRITERIA**  
ROLLED EROSION CONTROL PRODUCTS (RECPs) AND HYDRAULIC EROSION CONTROL PRODUCTS (HECPs):

-INSTALLATION AND STAPLING OF RECPs AND APPLICATION RATES FOR THE HECPs SHALL PROVIDING A MICROCLIMATE THAT PROTECTS YOUNG VEGETATION CONFORM TO MANUFACTURER'S GUIDELINES FOR APPLICATION

SHORT-TERM RECPs AS A MINIMUM SHALL BE USED TO STABILIZE CONCENTRATED FLOW AREAS WITH A VELOCITY LES THAN 5FT/SEC ON SLOPES 3:1 OR CONFORM TO MANUFACTURER'S GUIDELINES FOR APPLICATION GREATER WITH A HEIGHT OF 10 FEET OR GREATER

**MATERIALS - HECP**  
HYDRAULIC EROSION CONTROL PRODUCTS SHALL BE PREPACKAGED FROM THE MANUFACTURER. FIELD MIXING OF PERFORMANCE ENHANCING ADDITIVES WILL NOT BE ALLOWED. FIBEROUS COMPONENTS SHOULD BE ALL NATURAL OR BIODEGRADABLE.

**MATERIALS - HECP**  
HYDRAULIC EROSION CONTROL PRODUCTS SHALL BE PREPACKAGED FROM THE MANUFACTURER. FIELD MIXING OF PERFORMANCE ENHANCING ADDITIVES WILL NOT BE ALLOWED. FIBEROUS COMPONENTS SHOULD BE ALL NATURAL OR BIODEGRADABLE.

PRODUCTS SHOULD BE DETERMINED TO BE NON-TOXIC IN ACCORDANCE WITH EPA-821-R-02-012.

**MATERIALS - RECP**  
BLANKETS SHALL BE NONTOXIC TO VEGETATION, SEED, OR WILDLIFE. PRODUCTS SHALL BE DETERMINED TO BE NON-TOXIC IN ACCORDANCE WITH EPA-821-R-02-012. AT MINIMUM, THE PLASTIC OR BIODEGRADABLE NETTING SHALL BE STITCHED TO THE FIBROUS MATRIX TO MAXIMIZE STRENGTH AND PROVIDE FOR EASE OF HANDLING.

RECPs ARE CATEGORIZED AS FOLLOWS:

a. SHORT-TERM  
(FUNCTIONAL LONGEVITY 12 MO.)

i. PHOTODEGRADABLE  
STRAW BLANKETS WITH A TOP AND BOTTOM SIDE PHOTO DEGRADABLE NET. THE MAXIMUM SIZE OF THE MESH SHOULD BE OPENINGS OF 1/2" X 1/2". THE BLANKET SHOULD BE SEWN TOGETHER ON 1.5" CENTERS WITH DEGRADABLE THREAD. MINIMUM THICKNESS SHOULD BE 0.35" AND MINIMUM DENSITY SHOULD BE 0.5 LBS PER SQUARE YARD.

ii. BIODEGRADABLE  
STRAW BLANKETS WITH A TOP AND BOTTOM SIDE BIODEGRADABLE JUTE NET. THE TOP SIDE NET SHOULD CONSIST OF MACHINE DIRECTION STRANDS THAT ARE TWISTED TOGETHER AND THEN INTERWOVEN WITH CROSS DIRECTION STRANDS (LENO WEAVE). THE BOTTOM NET MAY BE LENO WEAVE OR OTHERWISE TO MEET REQUIREMENTS. THE APPROPRIATE SIZE OF THE MESH SHOULD BE OPENINGS OF 0.5" X 1.0". THE BLANKET SHOULD BE SEWN TOGETHER ON 1.5" CENTERS WITH DEGRADABLE THREAD. MINIMUM THICKNESS SHOULD BE 0.25" AND MINIMUM DENSITY SHOULD BE 0.5 LBS PER SQUARE YARD.

**Ss** SLOPE STABILIZATION  
N.T.S.

**Tp** TOP SOILING



**DEFINITION**  
STRIPPING OFF THE MORE FERTILE TOP SOIL, STORING IT, THEN SPREADING IT OVER THE DISTURBED AREA AFTER COMPLETION OF CONSTRUCTION ACTIVITIES.

**PURPOSE**  
TO PROVIDE A SUITABLE SOIL MEDIUM FOR VEGETATIVE GROWTH ON AREAS WHERE OTHER MEASURES WILL NOT PRODUCE OR MAINTAIN A CONSIDERABLE STAND.

**CONDITIONS**  
THIS PRACTICE IS RECOMMENDED FOR SITES OF 2:1 OR FLATTER SLOPES WHERE:

1. THE TEXTURE OF THE EXPOSED SUBSOIL OR PARENT MATERIAL IS NOT SUITABLE TO PRODUCE ADEQUATE VEGETATIVE GROWTH
2. THE SOIL MATERIAL IS SO SHALLOW THAT THE ROOTING ZONE IS NOT DEEP ENOUGH TO SUPPORT PLANTS WITH CONTINUING SUPPLIES OF MOISTURE AND FOOD
3. THE SOIL TO BE VEGETATED CONTAINS MATERIAL TOXIC TO PLANT GROWTH.

**CONSTRUCTION SPECIFICATIONS**

**Materials**  
TOPSOIL SHOULD BE FRIABLE AND LOAMY, FREE OF DEBRIS, OBJECTIONABLE WEEDS AND STONES AND CONTAIN NO TOXIC SUBSTANCE THAT MAY BE HARMFUL TO PLANT GROWTH. A pH RANGE OF 5.0-7.5 IS ACCEPTABLE SOLUBLE SALTS SHOULD NOT EXCEED 500 PPM.

**Testing**  
FIELD EXPLORATION SHOULD BE MADE TO DETERMINE WHETHER THE QUANTITY AND QUALITY OF SURFACE SOIL JUSTIFIES STRIPPING.

**Tp** SLOPTOP SOILING  
N.T.S.

**STRIPPING**  
STRIPPING SHOULD BE CONFINED TO THE IMMEDIATE CONSTRUCTION AREA.  
A 4 TO 6 INCH STRIPPING DEPTH IS COMMON, BUT MAY VARY DEPENDING ON THE PARTICULAR SOIL.

**Topsoil pH**  
IF pH VALUE IS LESS THAN 6.0, LIME SHALL BE APPLIED AND INCORPORATED WITH THE TOPSOIL TO ADJUST THE pH TO 6.5 OR HIGHER. TOPSOILS CONTAINING SOLUBLE SALTS GREATER THAN 500 PARTS PER MILLION SHALL NOT BE USED.

**Stockpiles**  
THE LOCATION OF TOPSOIL STOCKPILES SHOULD NOT OBSTRUCT NATURAL DRAINAGE OR CAUSE OFF-SITE ENVIRONMENTAL DAMAGE.

**Stabilization**  
STOCKPILES SHALL BE CONTAINED BY SEDIMENT BARRIERS TO PREVENT SEDIMENTATION ON ADJACENT AREAS. STOCKPILES SHALL BE STABILIZED IN ACCORDANCE WITH SPECIFICATIONS Ds1 and Ds2 - Disturbed Area Stabilization (With Mulching) and (With Temporary Grassing), RESPECTIVELY OR, Tac-Tackifiers

**Site Preparation**  
(Where topsoil is to be added)

Topsoiling - WHEN TOPSOILING, MAINTAIN NEEDED EROSION CONTROL PRACTICES SUCH AS DIVERSIONS, GRADE STABILIZATION STRUCTURES, SEDIMENT BASINS, ETC.

Grading-GRADES ON THE AREAS TO BE TOPSOILED THAT HAVE BEEN PREVIOUSLY ESTABLISHED SHALL BE MAINTAINED.

Liming-SOIL TESTS SHOULD BE USED TO DETERMINE THE pH OF THE SOIL. WHERE THE pH OF THE SUBSOIL IS 5.0 OR LESS OR COMPOSED OF HEAVY CLAYS, AGRICULTURAL LIMESTONE SHALL BE SPREAD AT THE RATE OF 100 POUNDS PER 1,000 SQUARE FEET. LIME SHALL BE DISTRIBUTED UNIFORMLY OVER DESIGNATED AREAS AND WORKED INTO THE SOIL IN CONJUNCTION WITH TILLAGE OPERATIONS AS DESCRIBED IN THE FOLLOWING PROCEDURE.

Bonding-USE ONE OF THE FOLLOWING METHODS TO INSURE BONDING OF TOPSOIL AND SUBSOIL:

1. TILLING, AFTER THE AREAS TO BE TOPSOILED HAVE BEEN BROUGHT TO GRADE, AND IMMEDIATELY PRIOR TO DUMPING AND SPREADING THE TOPSOIL, THE SUBGRADE SHALL BE LOOSENEED BY DISCING OR SCARIFYING TO THE DEPTH OF AT LEAST 3 INCHES TO PERMIT BONDING OF THE TOPSOIL TO THE SUBSOIL.

**GSWCC** GEORGIA SOIL AND WATER CONSERVATION COMMISSION

**Yasmin Moreno**  
Level II Certified Design Professional

CERTIFICATION NUMBER: 0000029509  
ISSUED: 06/27/2021 EXPIRES: 06/27/2024



CLIENT:  
**STONECREST**  
City of Stonecrest  
3120 Stonecrest Blvd  
Stonecrest, GA 30038  
770-224-0200

REVISIONS		
NO.	DATE	DESCRIPTION

**CERM**

1990 Lakeside Parkway  
Suite 300  
Tucker, GA, 30084  
O: 678.999.0173  
F: 678.999.0186  
[www.cerm.com](http://www.cerm.com)

PROJECT:  
PANOLA SHOALS RIVERBANK STABILIZATION AND RESTORATION PROJECT  
TAX ID: 16 016 03 002  
LAND LOT 17 16th DISTRICT CITY OF STONECREST DEKALB COUNTY, GEORGIA

**DESIGN TEAM**

DESIGN BY	CN
DRAWN BY	JD
CHECKED BY	YM

CERM PROJECT NO. 1468A-000A  
CLIENT PROJECT NO. 21-06210-Co018-00

**DATE**  
JUNE 29, 2022

**SHEET TITLE**  
EROSION CONTROL DETAILS

**SHEET No**  
C-08-09

$\phi = 30^\circ$  | FINE TO MEDIUM SAND or SILTY SAND

**LOAD CONDITION B** | 250 lb/ft<sup>2</sup> (12 kPa) LIVE LOAD SURCHARGE, NO BACK SLOPE, NO TOE SLOPE

**16.5-FOOT (5.03 m) HIGH SECTION**

- (3) 28" (710 mm) Blocks
- (2) 52" (1320 mm) XL Blocks
- (1) 72" (1830 mm) XL Block
- (1) 96" (2440 mm) XL Block

**PRELIMINARY**  
Professional Engineering Design  
Required for Construction

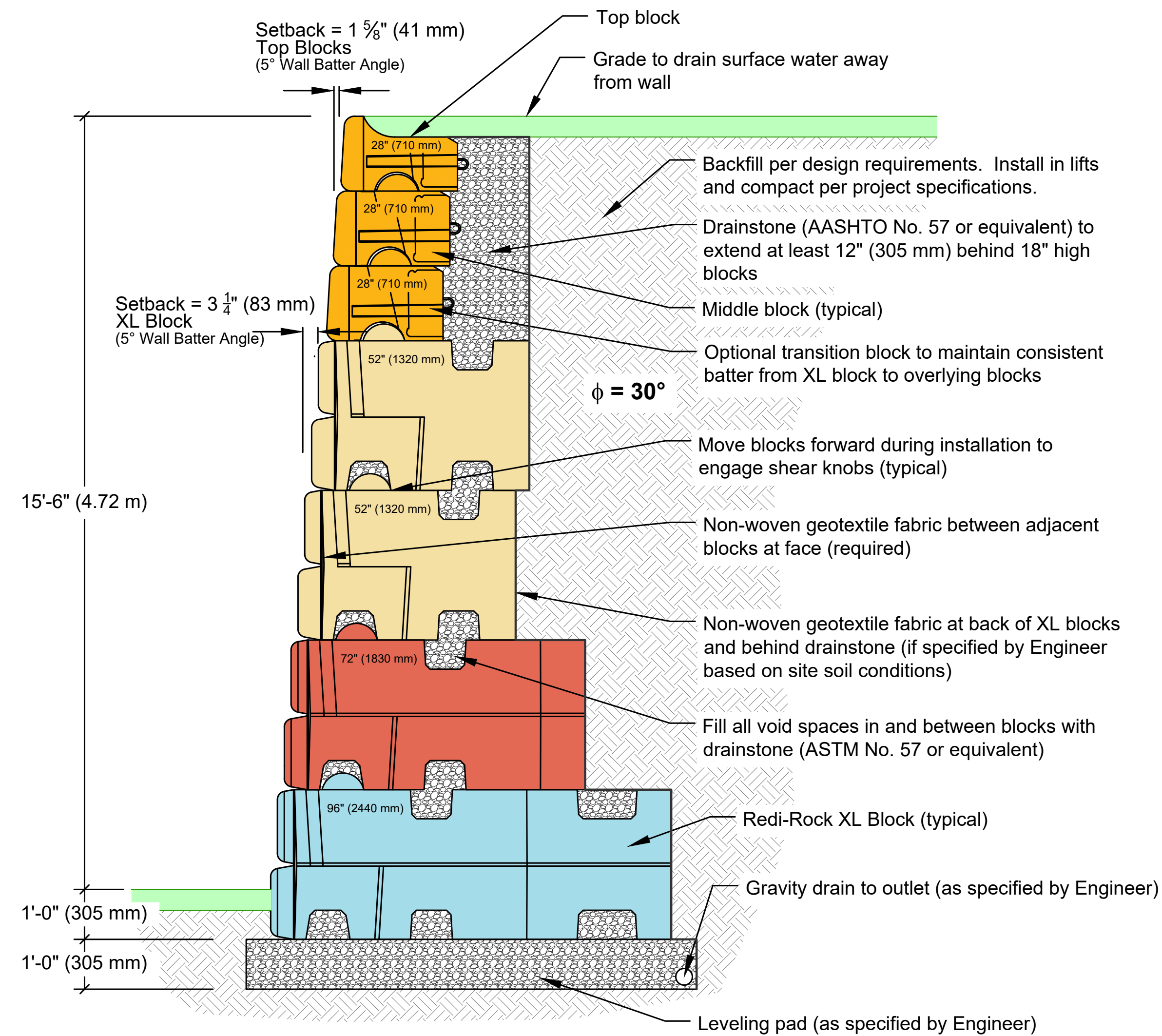

This drawing is for reference only. Determination of the suitability and/or manner of use of any details contained in this document is the sole responsibility of the design engineer of record. Final project designs, including all construction details, shall be prepared by a licensed professional engineer using the actual conditions of the proposed site. Final wall design must address both internal and external drainage and all modes of wall stability.

N. Lindwall  
J. Johnson  
May 8, 2019  
1 of 1

**Preliminary Wall Section**  
Fine to Medium Sand or Silty Sand,  $\phi = 30^\circ$   
250 lb/ft<sup>2</sup> (12 kPa) Live Load Surcharge  
B\_30\_XL\_198\_cad.dwg

$\phi = 30^\circ$  | FINE TO MEDIUM SAND or SILTY SAND

**LOAD CONDITION A** | NO LIVE LOAD SURCHARGE, NO BACK SLOPE, NO TOE SLOPE

**5 BLOCK HIGH SECTION**

- (4) 28" (710 mm) Blocks
- (1) 41" (1030 mm) Block

**PRELIMINARY**  
Professional Engineering Design  
Required for Construction

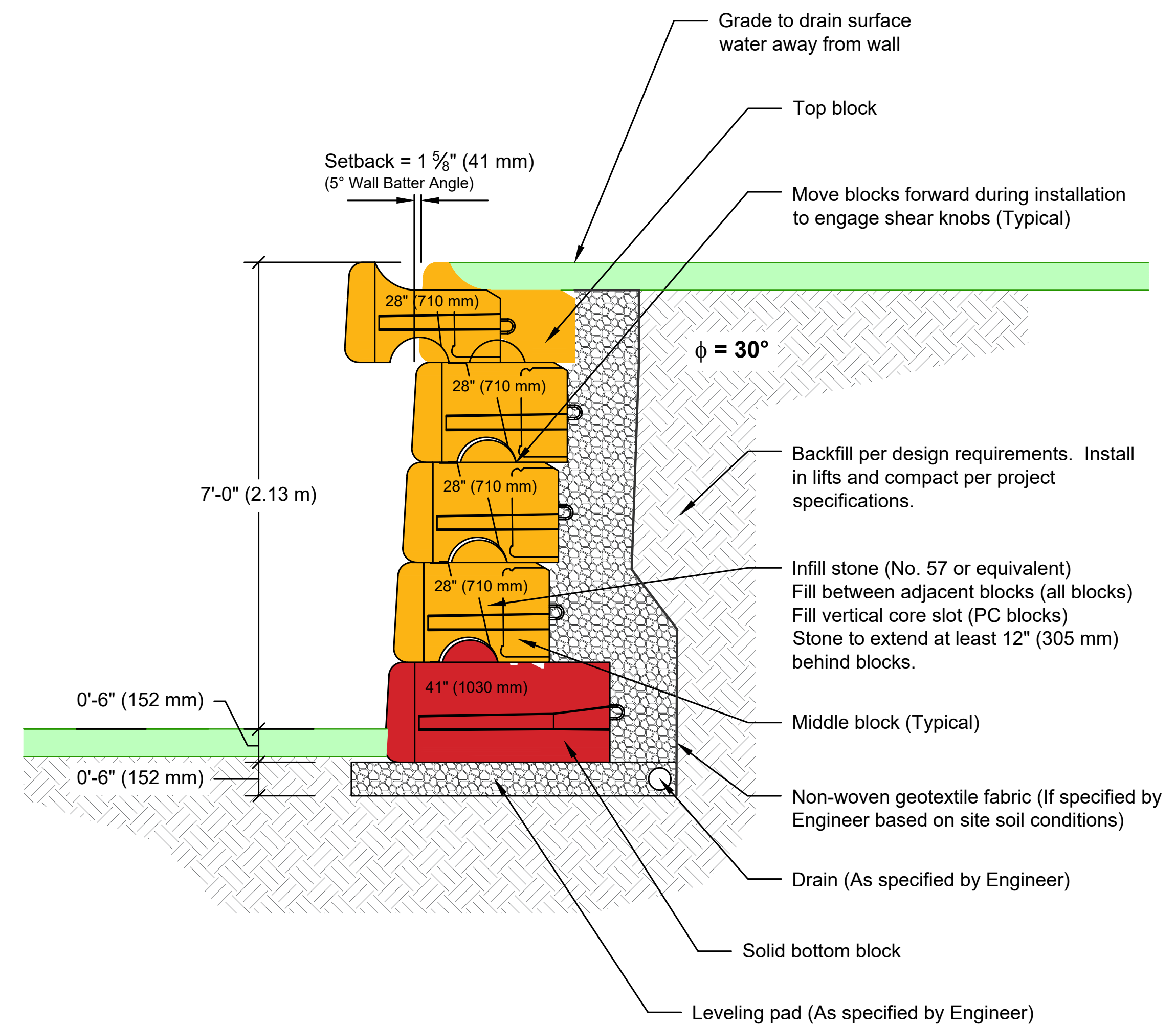

This drawing is for reference only. Determination of the suitability and/or manner of use of any details contained in this document is the sole responsibility of the design engineer of record. Final project designs, including all construction details, shall be prepared by a licensed professional engineer using the actual conditions of the proposed site. Final wall design must address both internal and external drainage and all modes of wall stability.

C. Kruger  
J. Johnson  
June 8, 2015  
1 of 1

**Preliminary Wall Section**  
Fine to Medium Sand or Silty Sand,  $\phi = 30^\circ$   
No Live Load Surcharge, No Back Slope, No Toe Slope  
A\_30\_B\_41\_90\_cad.dwg

CLIENT:



City of Stonecrest  
3120 Stonecrest Blvd  
Stonecrest, GA 30038  
770-224-0200

REVISIONS		
NO.	DATE	DESCRIPTION



1990 Lakeside Parkway  
Suite 300  
Tucker, GA, 30084  
O: 678.999.0173  
F: 678.999.0186  
[www.cerm.com](http://www.cerm.com)

PANOLA SHOALS RIVERBANK STABILIZATION  
AND RESTORATION PROJECT  
TAX ID: 16 016 03 002  
LAND LOT 17 16th DISTRICT  
CITY OF STONECREST  
DEKALB COUNTY, GEORGIA

PROJECT:

DESIGN TEAM	
DESIGN BY	CN
DRAWN BY	JD
CHECKED BY	YM

CERM PROJECT NO. 1468A-000A  
CLIENT PROJECT NO. 21-06210-Co018-00

DATE
JUNE 29, 2022
SHEET TITLE
<b>CONSTRUCTION DETAILS</b>
SHEET No
<b>C-09-01</b>



G:\Project Operations\Projects\Active Projects\2021-1468A-000A\_City of Stonecrest\_South River Stream Bank Restoration\0 - Design Documents\02 Plans\C-09 Construction Details.dwg Jul 06, 2022 - 5:25pm

**NOTES**

1. JOINT DETAILS SHALL ADHERE TO GA DOT 5046H.
2. CONCRETE SHALL ADHERE TO GDOT SPECIFICATION 430 AND ANY SPECIFICATION REFERENCED IN THAT SPEC TO COMPLETE THE WORK.

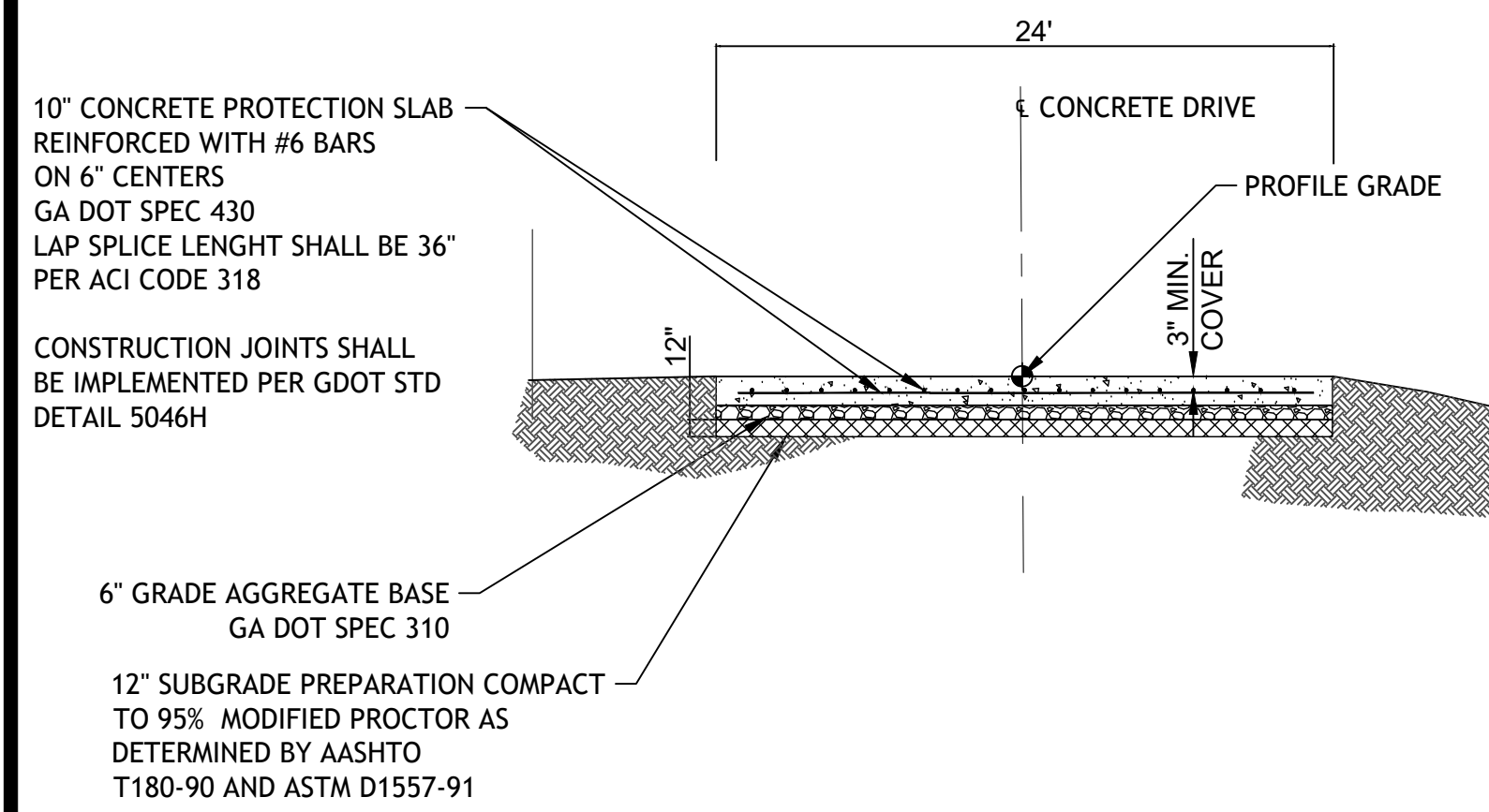

**1 SECTION A-A CONCRETE DRIVE**  
NOT TO SCALE

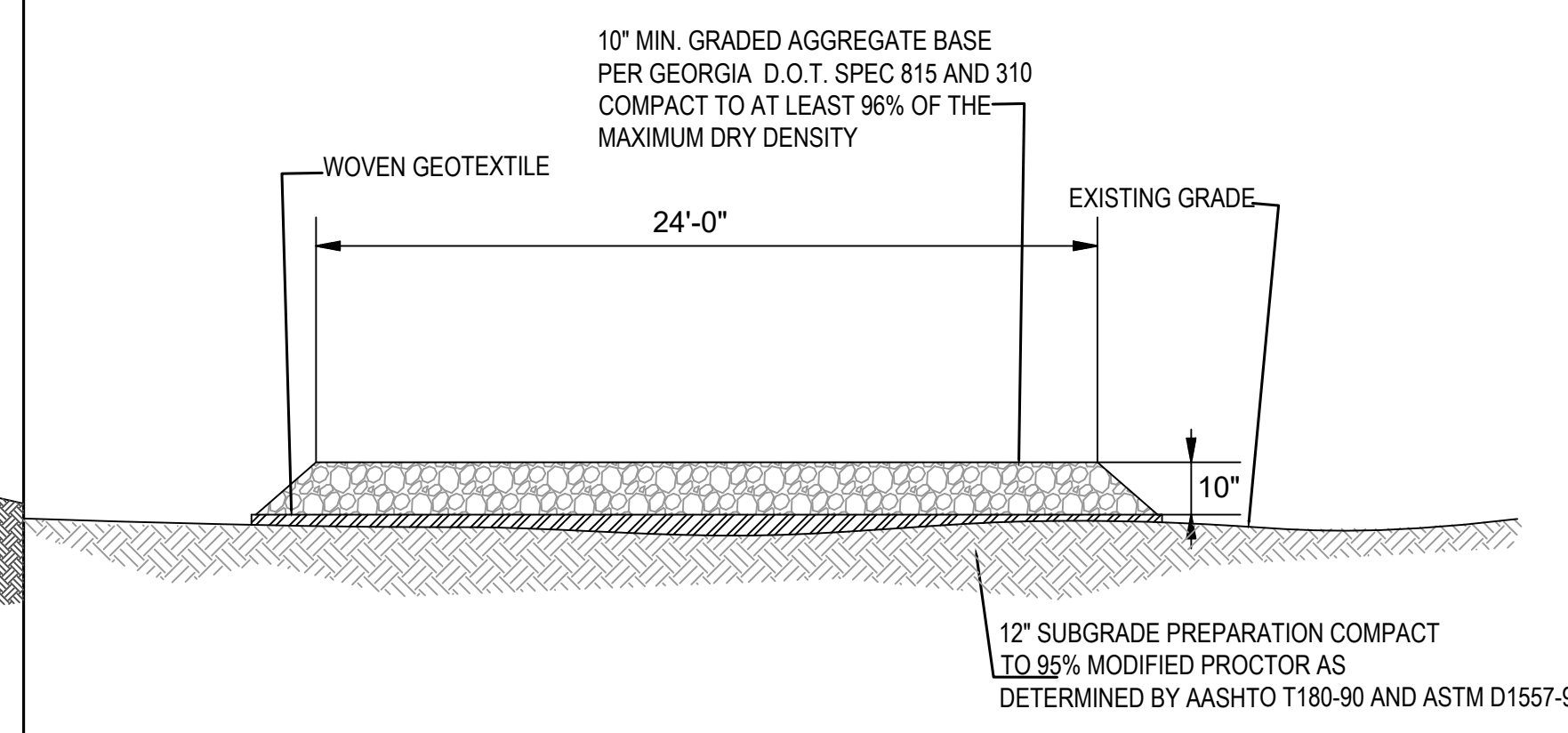

**2 GRAVEL ACCESS ROAD**  
NOT TO SCALE

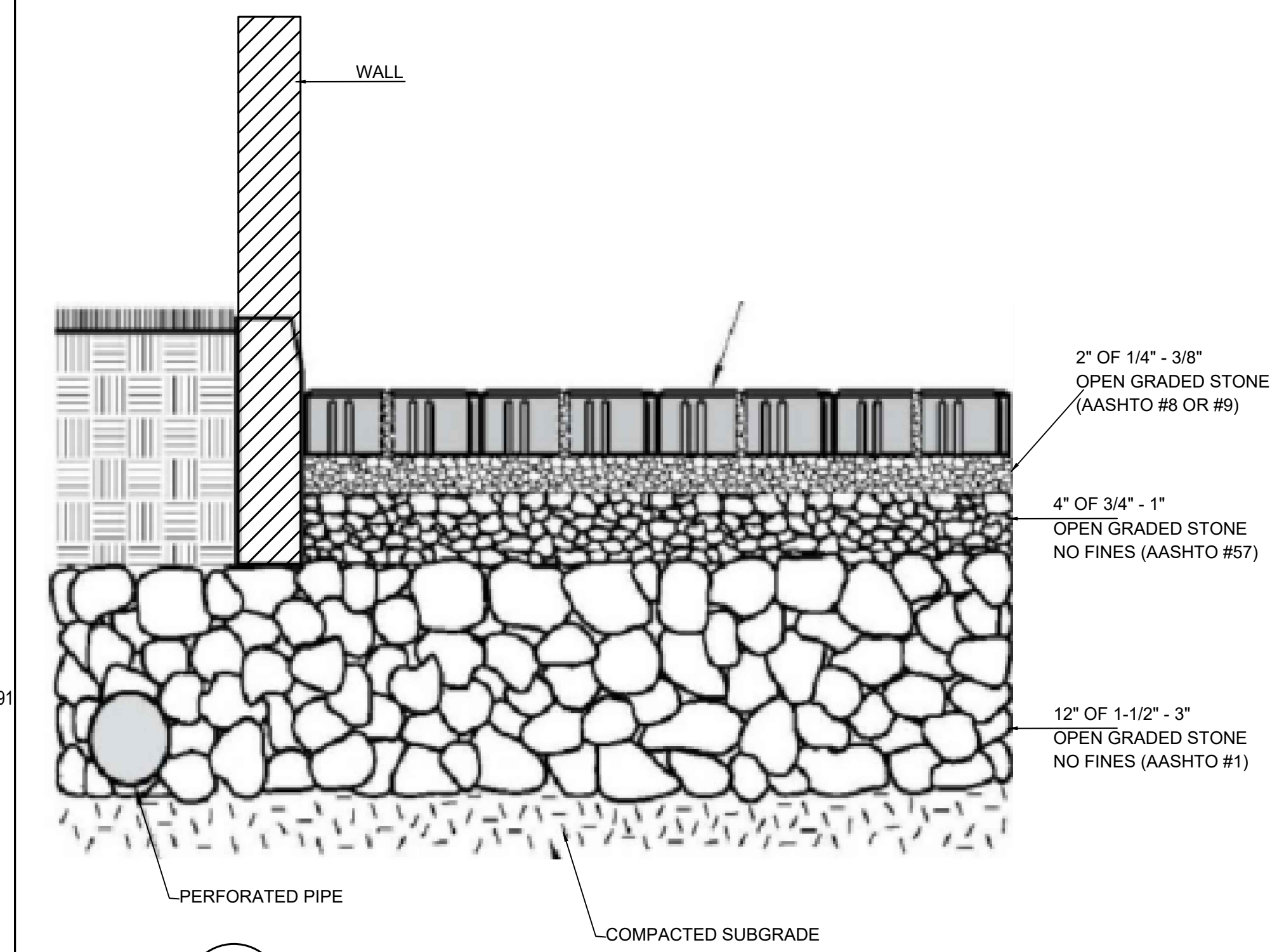

**3 PAVER DETAIL**  
NOT TO SCALE

PULL POSTS SHALL BE REQUIRED AT 250 FT. INTERVALS AND AT GRADE CHANGES EXCEEDING 5%. FOR CORNER AND PULL POSTS, RAIL AND TENSION ROD PANEL TO JOIN POST IN BOTH DIRECTIONS.

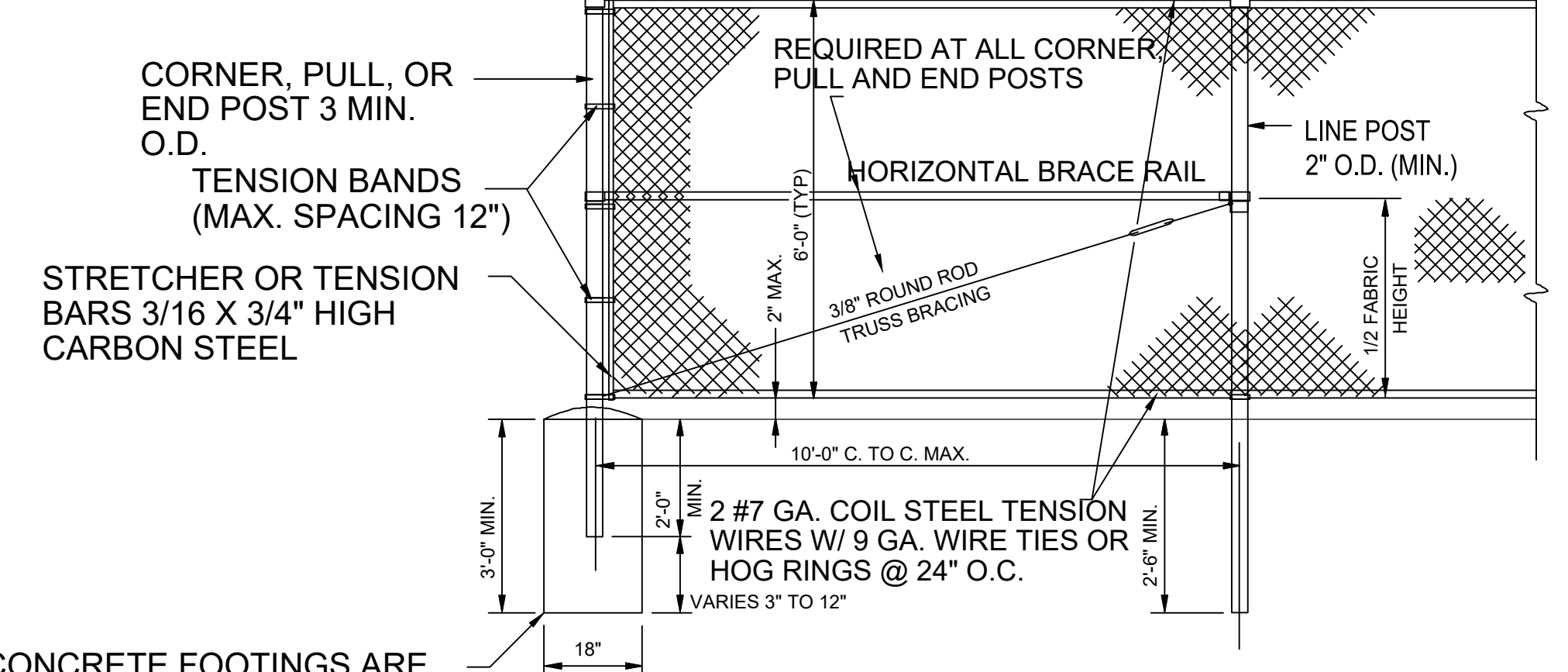

**TEMPORARY CHAIN-LINK WIRE FENCE**  
NOT TO SCALE

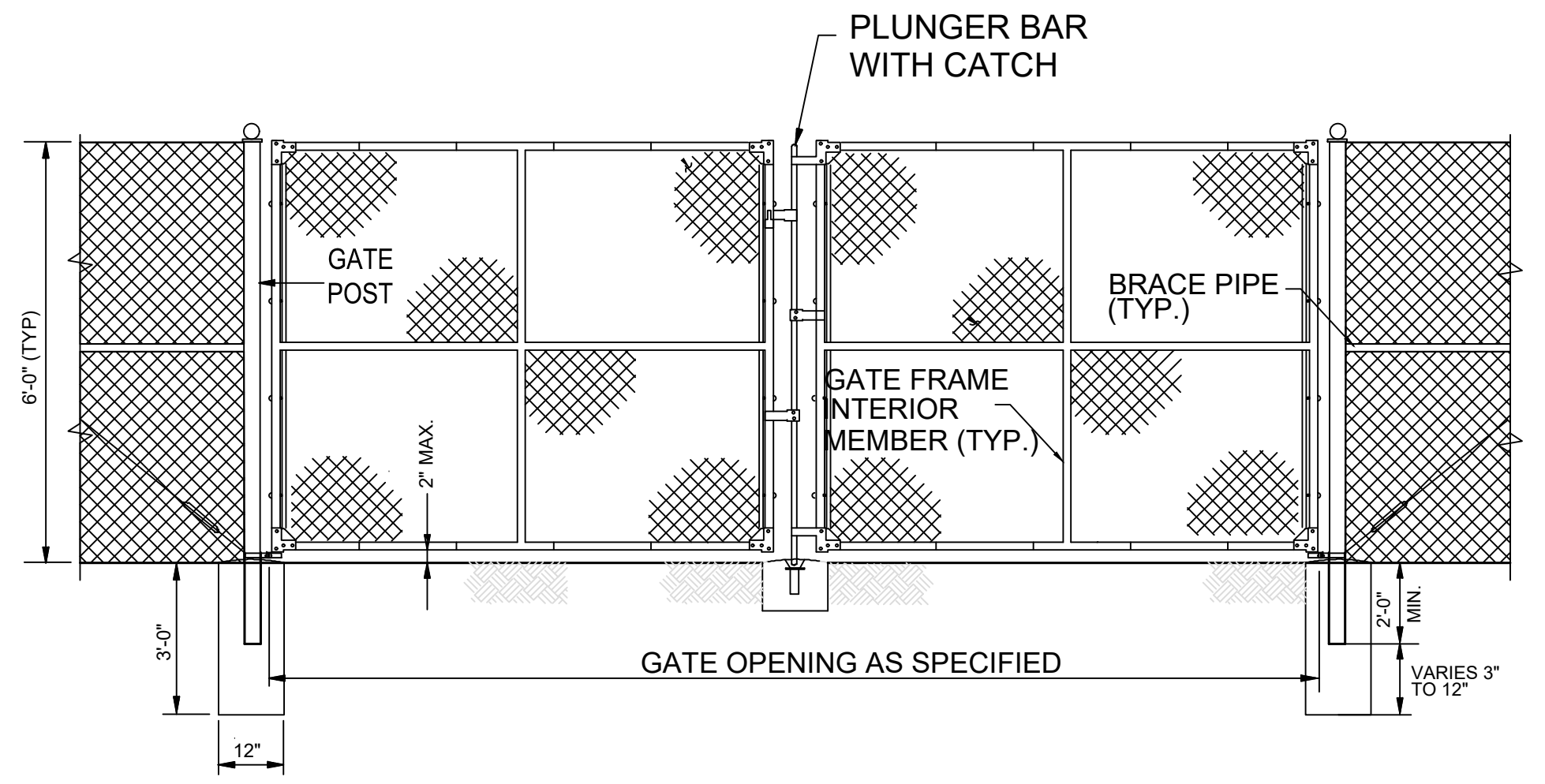

**DOUBLE SWING GATE**  
NOT TO SCALE

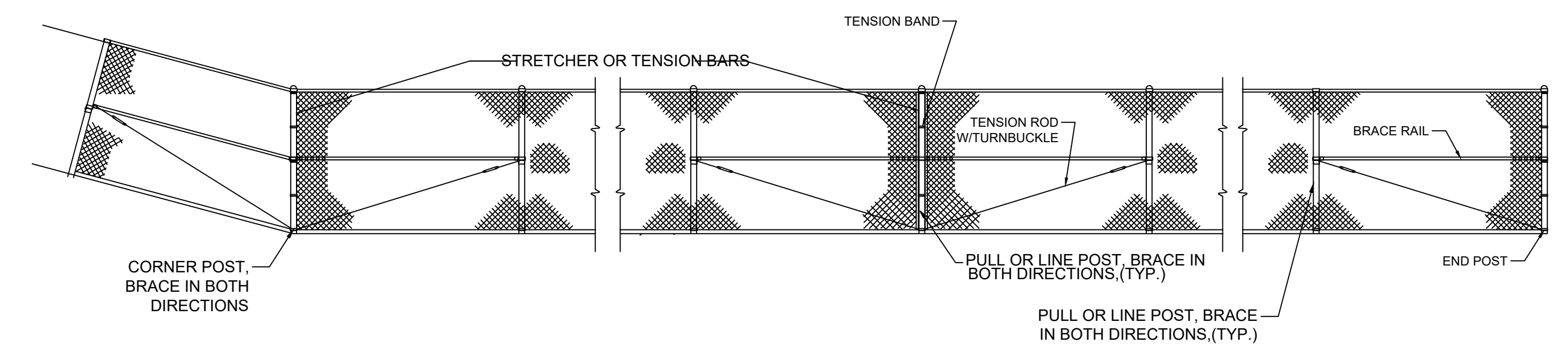

**4 METHOD OF BRACING END, CORNER AND PULL POST ON GRADE AND BARRIER**

CLIENT:  
**STONECREST**  
City of Stonecrest  
3120 Stonecrest Blvd  
Stonecrest, GA 30038  
770-224-0200

REVISIONS		
NO.	DATE	DESCRIPTION



1990 Lakeside Parkway  
Suite 300  
Tucker, GA, 30084  
O: 678.999.0173  
F: 678.999.0186  
[www.cerm.com](http://www.cerm.com)

PROJECT:  
PANOLA SHOALS RIVERBANK STABILIZATION  
AND RESTORATION PROJECT  
TAX ID: 16 016 03 002  
LAND LOT 17 16th DISTRICT  
CITY OF STONECREST  
DEKALB COUNTY, GEORGIA

DESIGN TEAM	
DESIGN BY	CN
DRAWN BY	JD
CHECKED BY	YM

CERM PROJECT NO. 1468A-000A  
CLIENT PROJECT NO. 21-06210-Co018-00

DATE  
JUNE 29, 2022

SHEET TITLE  
**CONSTRUCTION  
DETAILS**

SHEET No  
**C-09-02**



PRIOR TO DIGGING  
VERIFY LOCATION  
OF EXISTING UTILITIES  
AND CONTACT GEORGIA 811  
<https://www.georgia811.com/>

G:\Project\_Operations\Projects\Active Projects\2021-1468A-000A City of Stonecrest South River Stream Bank Restoration\02 Plans\C-09 Construction Details.dwg Jul 06, 2022 - 5:28pm

G:\Project\_Operations\Projects\Active Projects\2021-1468A-000A\_City of Stonecrest\_South River Stream Bank Restoration\40 - Design Documents\02 Plans\C-14 Landscape Plan\_Render.dwg Jul 06, 2022 - 5:29pm

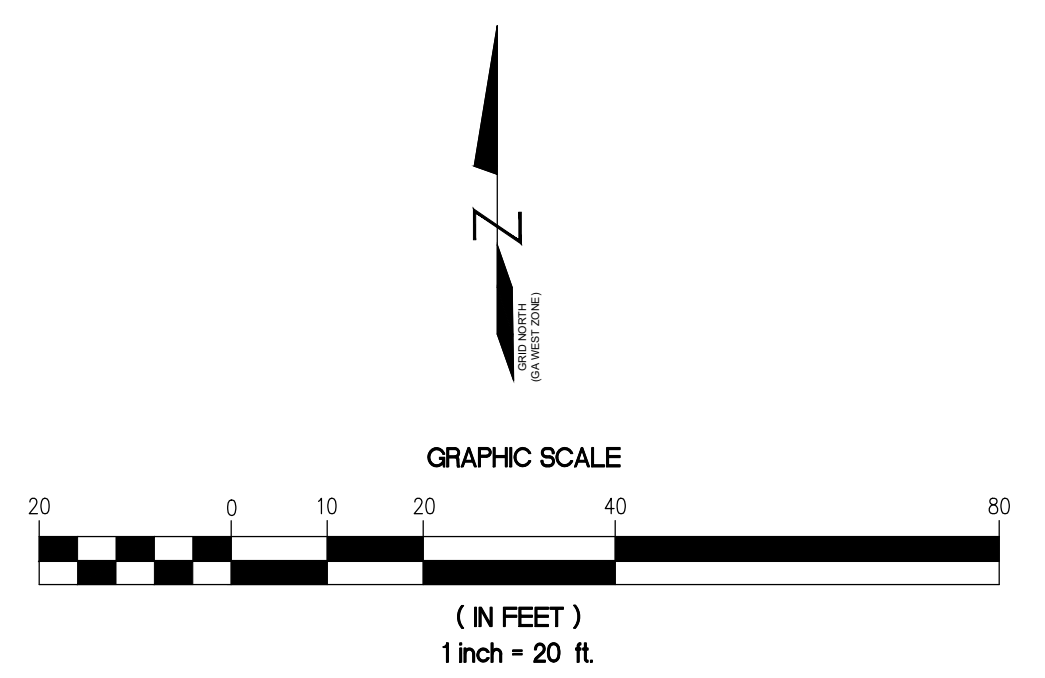
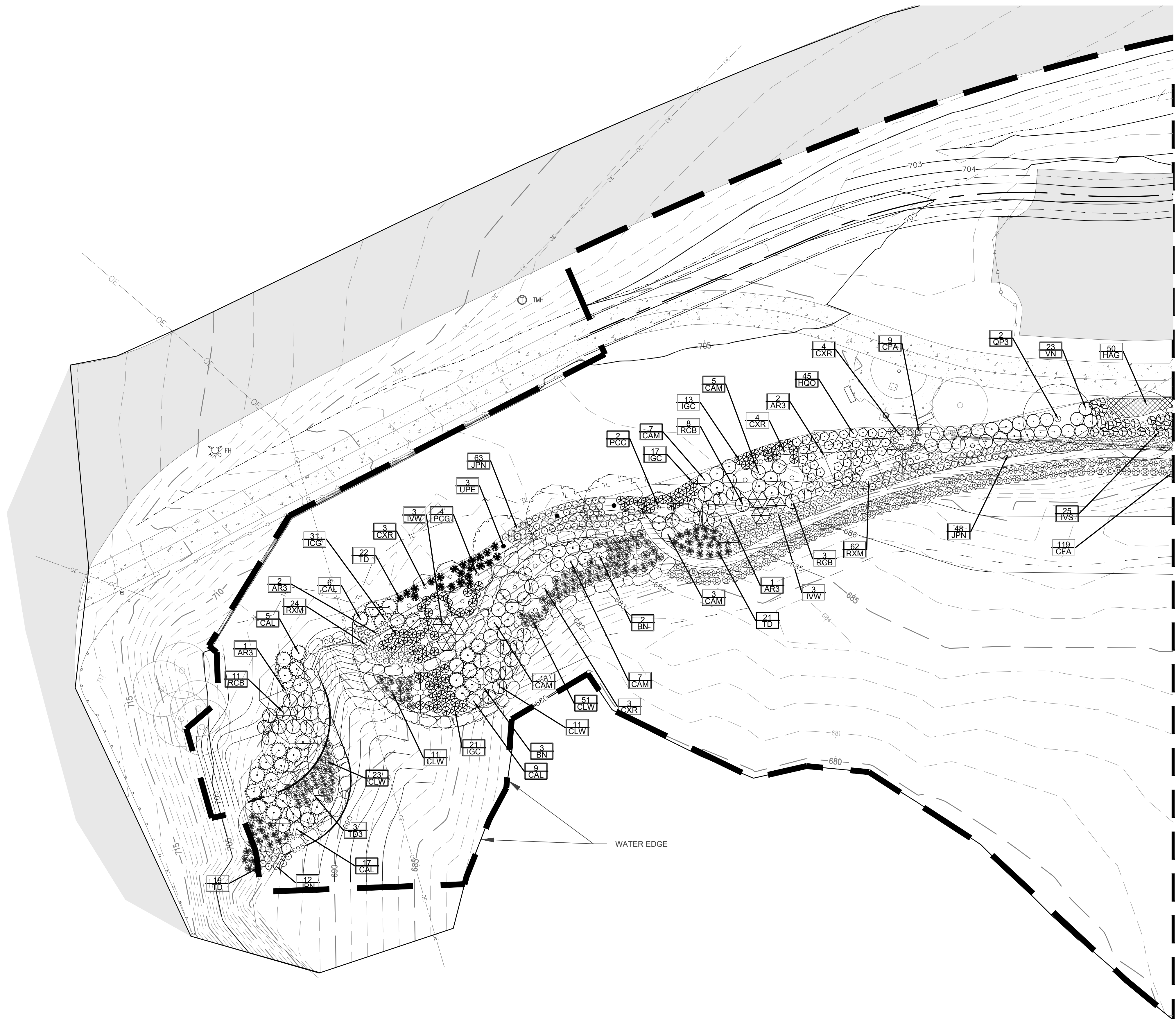

MATCHLINE SHEET C-14-02

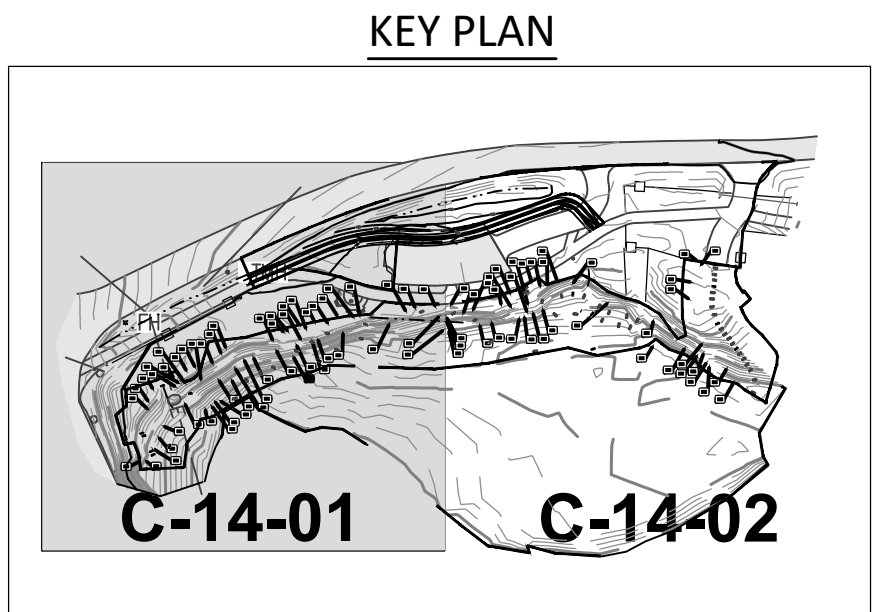

KEY PLAN

 PRIOR TO DIGGING  
VERIFY LOCATION  
OF EXISTING UTILITIES  
AND CONTACT GEORGIA 811  
<https://www.georgia811.com/>

CLIENT:  
  
 City of Stonecrest  
 3120 Stonecrest Blvd  
 Stonecrest, GA 30038  
 770-224-0200

  
 LANDSCAPE ARCHITECTURE  
 & URBAN PLANNING  
 DAVID GJERTSON, PL, AICP  
 404.200.1858  
 gjertsondesign.com

REVISIONS		
NO.	DATE	DESCRIPTION
1	5.06.22	LANDSCAPE REVISION

  
 CERM  
 1990 Lakeside Parkway  
 Suite 300  
 Tucker, GA, 30084  
 O: 678.999.0173  
 F: 678.999.0186  
[www.cerm.com](http://www.cerm.com)

PROJECT:  
 PANOLA SHOALS RIVERBANK STABILIZATION  
 AND RESTORATION PROJECT  
 TAX ID: 16 016 03 002  
 LAND LOT 17 16th DISTRICT  
 CITY OF STONECREST  
 DEKALB COUNTY, GEORGIA

DESIGN TEAM  
 DESIGN BY: CN  
 DRAWN BY: JD  
 CHECKED BY: YM

CERM PROJECT NO. 1468A-000A  
 CLIENT PROJECT NO. 21-06210-Co018-00

DATE  
 JUNE 29, 2022

SHEET TITLE  
 LANDSCAPE PLAN  
 EAST

SHEET No  
 C-14-01



C:\Project\_Operations\Projects\Active Projects\2021-1468A-000A\_City of Stonecrest\_South River\_Stream Bank\_Restoration\40 - Design Documents\02 Plans\C-14 Landscape Plan\_Render.dwg Jul 06, 2022 - 5:29pm

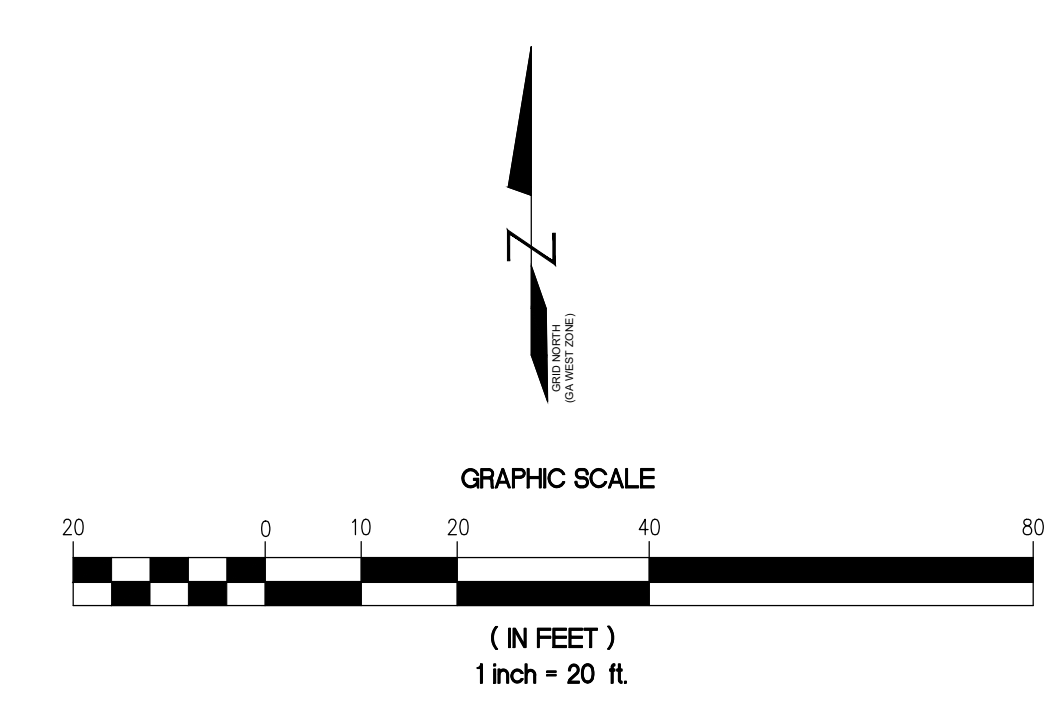
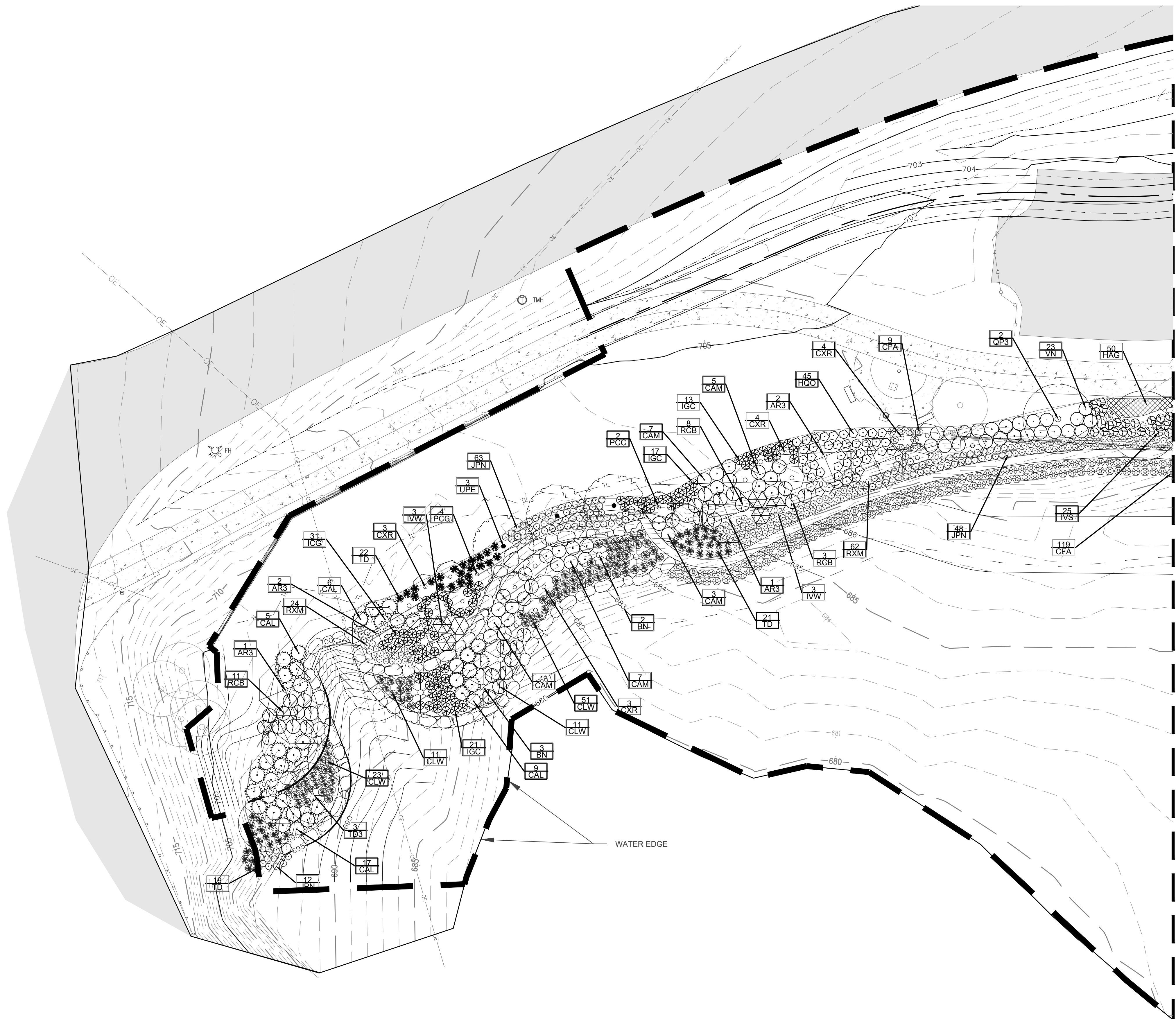

MATCHLINE SHEET C-14-02

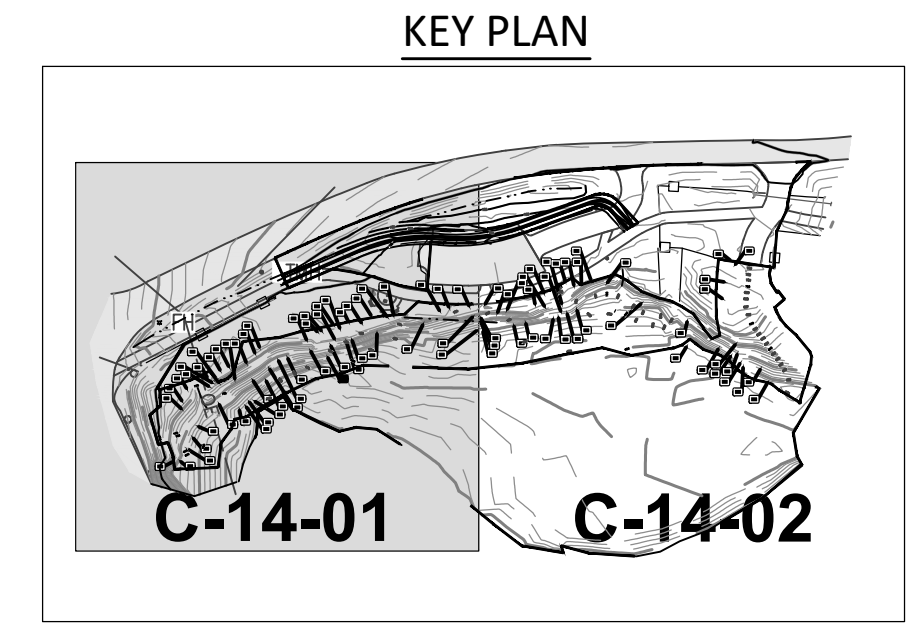

KEY PLAN

PRIOR TO DIGGING  
VERIFY LOCATION  
OF EXISTING UTILITIES  
AND CONTACT GEORGIA 811  
<https://www.georgia811.com/>

**CLIENT:**

City of Stonecrest  
3120 Stonecrest Blvd  
Stonecrest, GA 30038  
770-224-0200

LANDSCAPE ARCHITECTURE  
& URBAN PLANNING

DAVID GJERTSON, P.L.A., AICP  
404.200.1858  
gjertsondesign.com

REVISIONS		
NO.	DATE	DESCRIPTION
1	5.06.22	LANDSCAPE REVISION

C · E · R · M

1990 Lakeside Parkway  
Suite 300  
Tucker, GA, 30084  
O: 678.999.0173  
F: 678.999.0186  
[www.cerm.com](http://www.cerm.com)

PROJECT:

PANOLA SHOALS RIVERBANK STABILIZATION  
AND RESTORATION PROJECT  
TAX ID: 16 016 03 002  
LAND LOT 17 16th DISTRICT  
CITY OF STONECREST  
DEKALB COUNTY, GEORGIA

DESIGN TEAM	
DESIGN BY	CN
DRAWN BY	JD
CHECKED BY	YM

CERM PROJECT NO. 1468A-000A  
CLIENT PROJECT NO. 21-06210-Co018-00

<b>DATE</b>	JUNE 29, 2022
<b>SHEET TITLE</b>	LANDSCAPE PLAN EAST
<b>SHEET No</b>	C-14-01

C:\Project\_Operations\Projects\Active Projects\2021-1468A-000A City of Stonecrest South River Stream Bank Restoration\40 - Design Documents\02 Plans\C-14 Landscape Plan Render.dwg Jul 06, 2022 - 5:29pm

MATCHLINE SHEET C-14-01

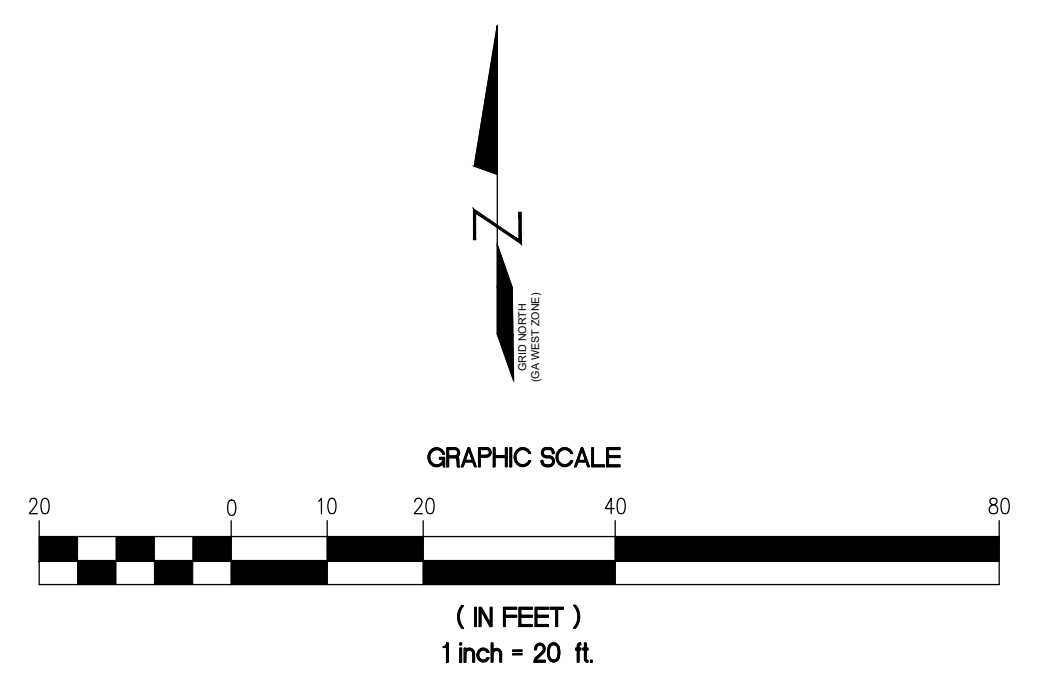
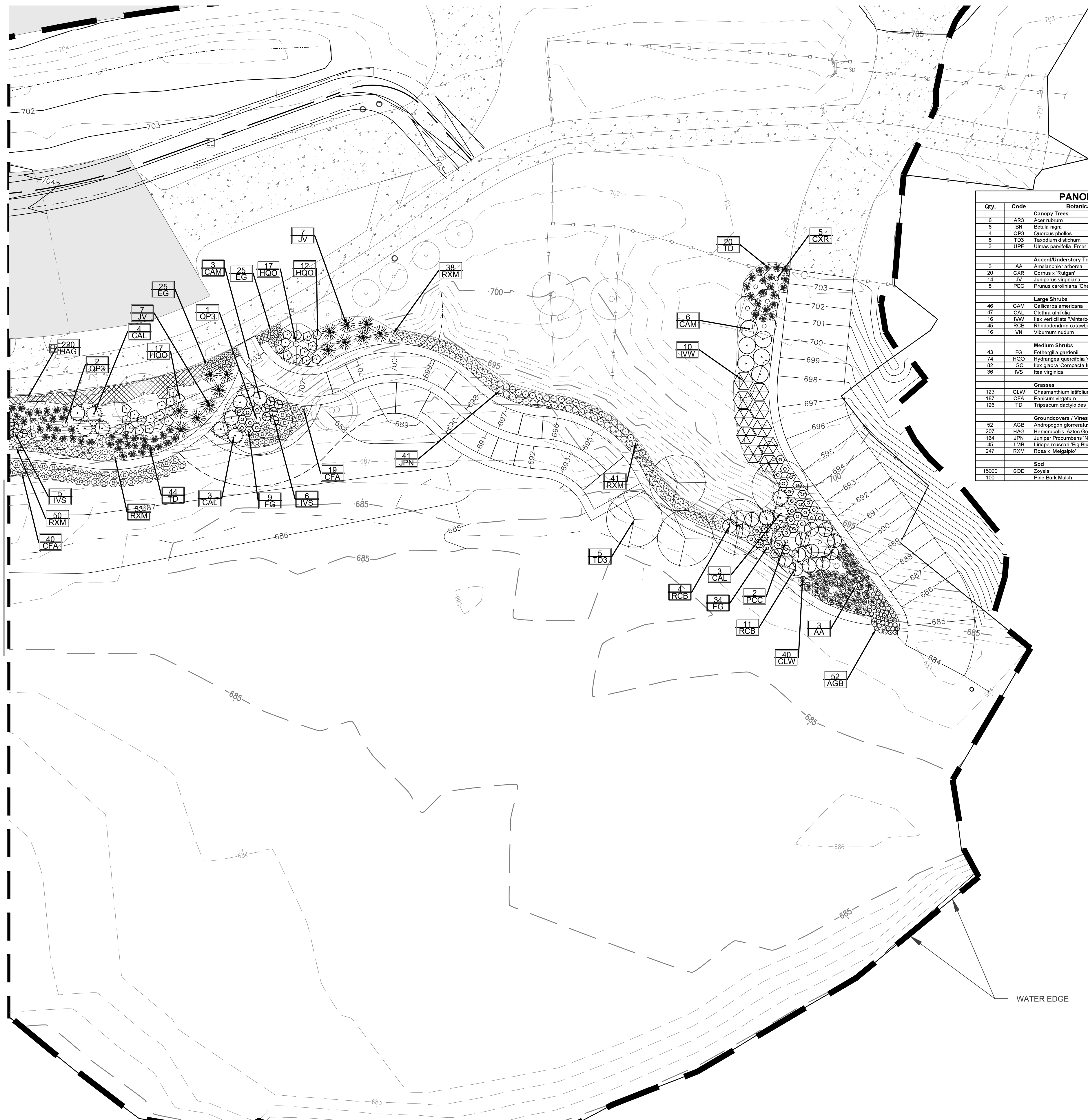

PANOLA SHOALS STREAMBANK RESTORATION - MASTER PLANT LIST									
Qty.	Code	Botanical Name	Common Name	Caliper	Height	Spread	Root Size	Comments	Spacing
6	AR3	Acer rubrum	Autumn Glory Red Maple	3"	8'-10"	6'-6"	B&B		
6	BN	Betula nigra	River Birch	6"-8"	6'-8"	3'-4"	30 Gal	Multi-trunk 1" Cal Min	
4	QP3	Quercus phellos	Willow Oak	3"	12'-14"	6'-8"	85 Gal		
8	TD3	Taxodium distichum	Bald Cypress	3"	8'-10"	4'-5"	B&B		
3	UPE	Ulmus parvifolia 'Emer II' P.P. #7552	Alleé Elm	2.5"	8'-10"	5'-5"	30 Gal		
<b>Accent/Understory Trees</b>									
3	AA	Amelanchier arborea	Downy Serviceberry	N/A	6'-8"	4'-5"	15 Gal		
20	CXR	Cornus x 'Rutigan'	Stellar Pink Dogwood	N/A	6'-8"	4'-5"	30 Gal	Multi-stem	
14	JV	Juniperus virginiana	Eastern Red Cedar	N/A	4"	2'-3"	7 Gal		
8	PCC	Prunus caroliniana 'Cherry Laurel'	Native Cherry Laurel	6"-8"	4'-5"	15 Gal			
<b>Large Shrubs</b>									
46	CAM	Callicarpa americana	American Beautyberry	24"-36"	18"-24"	3 Gal			4'
47	CAL	Clethra alnifolia	Sweet Pepperbush	24"-36"	18"-24"	3 Gal			4'
16	LVW	Ilex verticillata 'Winterberry'	Winterberry	36"	36"	7 Gal			5'
45	RCB	Rhododendron catawbiense 'Boursault'	Boursault Azalea	36"	36"	7 Gal			5'
16	VN	Viburnum nudum	Smooth Witherod	24"-36"	18"-24"	3 Gal			5'
<b>Medium Shrubs</b>									
43	FG	Fothergilla gardenii	Dwarf Fothergilla	18"-24"	18"-24"	3 Gal			3'
74	HOO	Hydrangea quercifolia 'OakLeaf'	OakLeaf Hydrangea	24"-36"	18"-24"	3 Gal			3'
92	IGC	Ilex glabra 'Compact Inkberry'	Compact Inkberry	18"-24"	18"-24"	3 Gal			3'
36	IVS	Itea virginica	Virginia Sweetspire	24"-36"	18"-24"	3 Gal			3'
<b>Grasses</b>									
123	CLW	Chasmodon latifolium	Wood Oats	18"-24"	18"	3 Gal			3'
187	CFA	Panicum virgatum	Switch Grass	18"-24"	18"	3 Gal			3'
128	TD	Tripogon dactyloides	Eastern Gamagrass	24"-36"	18"-24"	3 Gal			3'
<b>Groundcovers / Vines</b>									
52	AGB	Andropogon gerardi	Bushy Bluestem			6"	Pot		18"
207	HAG	Hemerocallis 'Zotac Gold'	Aztec Gold			6"	Full in pot		16"
184	JPN	Juniper Procumbens 'Nana'	Spreading Juniper			3 Gal	Full in pot		2.5'
45	LSB	Liriodendron muscari 'Big Blue'	Big Blue Liriodendron			1 Gal	Full in pot		18"
247	RXM	Rosa x 'Meigabou'	Red Drift Rose			1 Gal	Full in pot		2'
<b>Soil</b>									
15000	SOD	Zoysia	Zoysia Sod						
100			Pine Bark Mulch						

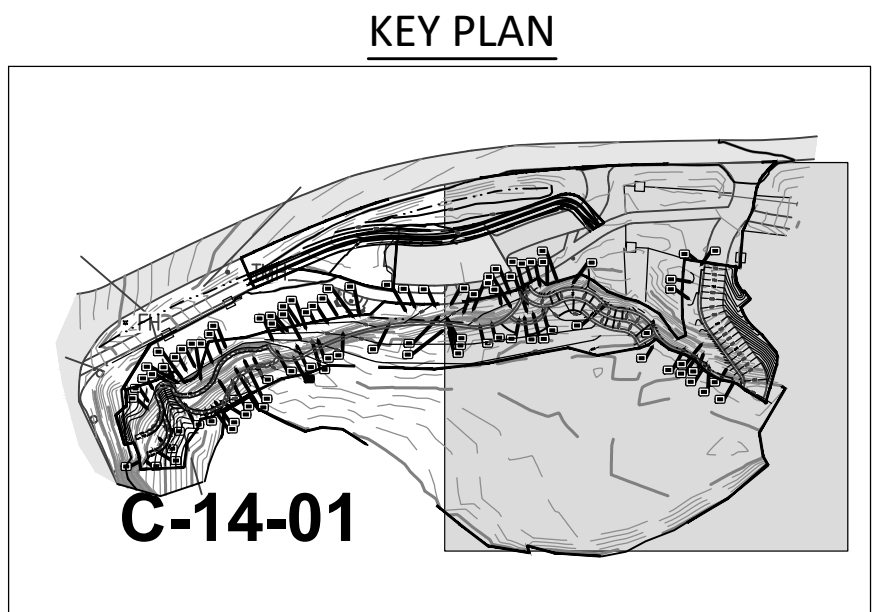

PRIOR TO DIGGING  
VERIFY LOCATION  
OF EXISTING UTILITIES  
AND CONTACT GEORGIA 811  
<https://www.georgia811.com/>

CLIENT:  
**STONECREST**  
City of Stonecrest  
3120 Stonecrest Blvd  
Stonecrest, GA 30038  
770-224-0200

**Gj:D**  
LANDSCAPE ARCHITECTURE  
& URBAN PLANNING  
DAVID GJERTSON, PLA, AICP  
404.200.1858  
gjertsondesign.com

REVISIONS		
NO.	DATE	DESCRIPTION
1	5.06.22	LANDSCAPE REVISION

**C · E · R · M**  
1990 Lakeside Parkway  
Suite 300  
Tucker, GA, 30084  
O: 678.999.0173  
F: 678.999.0186  
[www.cerm.com](http://www.cerm.com)

PROJECT:  
PANOLA SHOALS RIVERBANK STABILIZATION  
AND RESTORATION PROJECT  
TAX ID: 16 016 03 002  
LAND LOT 17 16th DISTRICT  
CITY OF STONECREST  
DEKALB COUNTY, GEORGIA

**DESIGN TEAM**  
DESIGN BY: CN  
DRAWN BY: JD  
CHECKED BY: YM

CERM PROJECT NO. 1468A-000A  
CLIENT PROJECT NO. 21-06210-Co018-00

**DATE**  
JUNE 29, 2022  
**SHEET TITLE**

**LANDSCAPE PLAN  
WEST**

**SHEET No**  
C-14-02

C:\Project\_Operations\Projects\Active Projects\2021-1468A-000A City of Stonecrest South River Stream Bank Restoration\40 - Design Documents\02 Plans\C-14 Landscape Plan Render.dwg Jul 06, 2022 - 5:29pm

MATCHLINE SHEET C-14-01

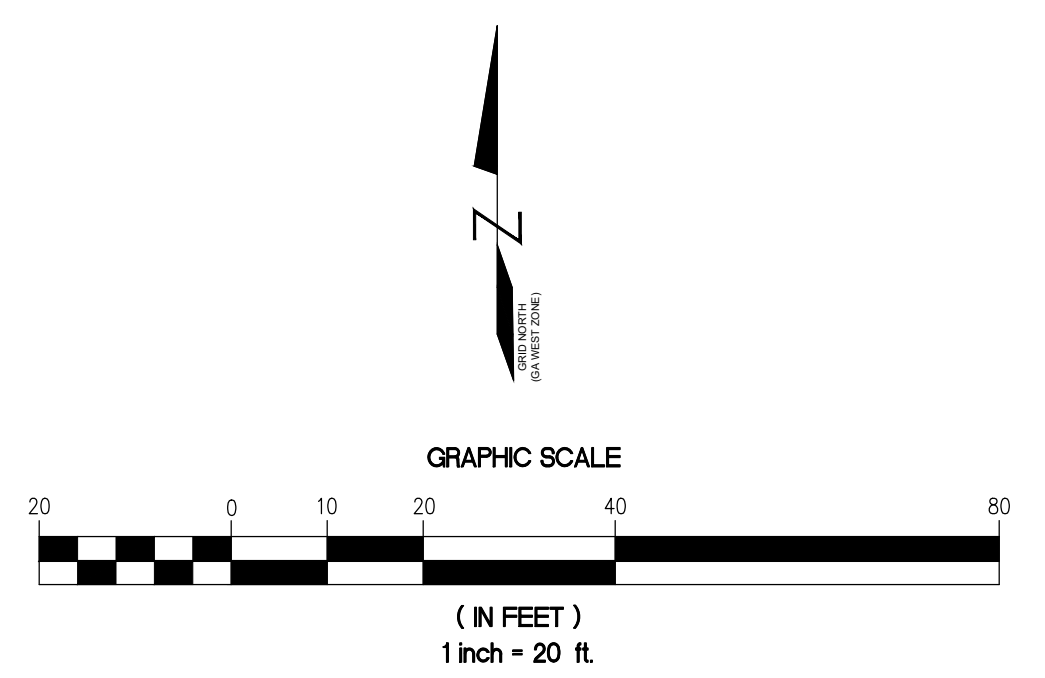

PANOLA SHOALS STREAMBANK RESTORATION - MASTER PLANT LIST									
Qty.	Code	Botanical Name	Common Name	Caliper	Height	Spread	Root Size	Comments	Spacing
<b>Canopy Trees</b>									
6	AR3	Acer rubrum	Autumn Glory Red Maple	3"	8'-10"	5'-6"	B&B		
6	BN	Betula nigra	River Birch	N/A	6'-8"	3'-4"	30 Gal	Multi-trunk, 1" Cal Min	
4	QP3	Quercus phellos	Willow Oak	3"	12'-14"	6'-8"	85 Gal		
8	TD3	Taxodium distichum	Bald Cypress	3"	8'-10"	4'-5"	B&B		
3	UPE	Ulmus parvifolia 'Emer II' P.P. #7552	Alleé Elm	2.5"	8'-10"	5'-5"	30 Gal		
<b>Accent/Understory Trees</b>									
3	AA	Amelanchier arborea	Downy Serviceberry	N/A	6'-8"	4'-5"	15 Gal		
20	CXR	Cornus x 'Rutgan'	Stellar Pink Dogwood	N/A	6'-8"	4'-5"	30 Gal	Multi-stem	
14	JI	Juniperus virginiana	Eastern Red Cedar	N/A	4"	2'-3"	7 Gal		
8	PCC	Prunus caroliniana 'Cherry Laurel'	Native Cherry Laurel	N/A	6'-8"	4'-5"	15 Gal		
<b>Large Shrubs</b>									
46	CAM	Callicarpa americana	American Beautyberry	24"-36"	18"-24"	3 Gal			4'
47	CAL	Clethra alnifolia	Sweet Pepperbush	24"-36"	18"-24"	3 Gal			4'
16	LVW	Ilex verticillata 'Winterberry'	Winterberry	36"	36"	7 Gal			5'
45	RCB	Rhododendron catawbiense 'Boursault'	Boursault Azalea	36"	36"	7 Gal			5'
16	VN	Viburnum nudum	Smooth Witherod	24"-36"	18"-24"	3 Gal			5'
<b>Medium Shrubs</b>									
43	FG	Fothergilla gardenii	Dwarf Fothergilla	18"-24"	18"-24"	3 Gal			3'
74	HOO	Hydrangea quercifolia 'OakLeaf'	OakLeaf Hydrangea	24"-36"	18"-24"	3 Gal			3'
92	IGC	Ilex glabra 'Compact Inkberry'	Compact Inkberry	18"-24"	18"-24"	3 Gal			3'
36	IVS	Itea virginica	Virginia Sweetspire	24"-36"	18"-24"	3 Gal			3'
<b>Grasses</b>									
123	CLW	Chasmodon latifolium	Wood Oats	18"-24"	18"	3 Gal			3'
187	CFA	Panicum virgatum	Switch Grass	18"-24"	18"	3 Gal			3'
128	TD	Tripogon dactyloides	Eastern Gamagrass	24"-36"	18"-24"	3 Gal			3'
<b>Groundcovers / Vines</b>									
52	AGB	Andropogon gerardi	Bushy Bluestem			12"	6"	Pot	18"
207	HAG	Hemerocallis 'Azttec Gold'	Aztec Gold					1 Gal	Full in pot
184	JPN	Juniper Procumbens 'Nana'	Spreading Juniper					3 Gal	Full in pot
45	LMB	Liriodendron muscari 'Big Blue'	Big Blue Liriodendron					1 Gal	Full in pot
247	RXM	Rosa x 'Meigabou'	Red Drift Rose					1 Gal	Full in pot
<b>Soil</b>									
15000	SOD	Zoysia	Zoysia Sod						
100			Pine Bark Mulch						

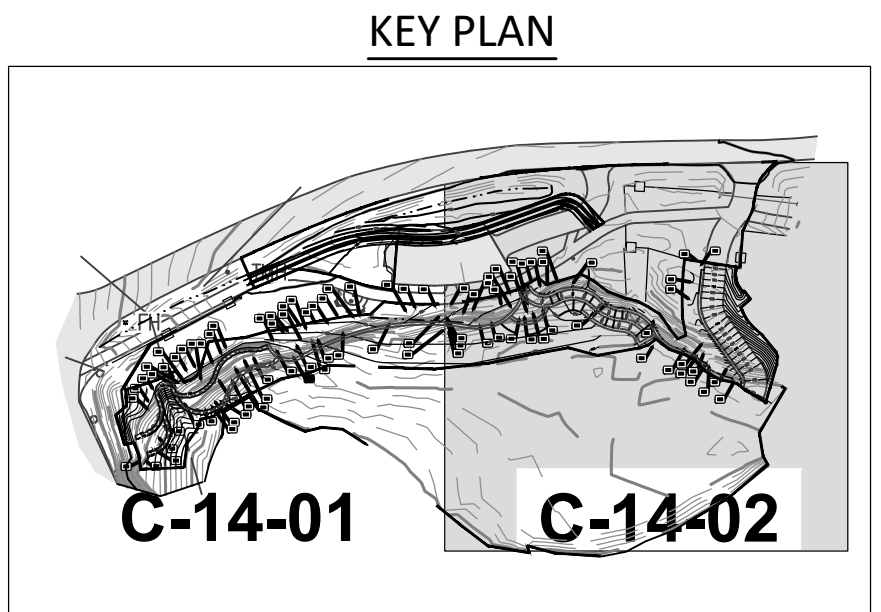

CLIENT:  
**STONECREST**  
 City of Stonecrest  
 3120 Stonecrest Blvd  
 Stonecrest, GA 30038  
 770-224-0200

**Gj:D**  
 LANDSCAPE ARCHITECTURE & URBAN PLANNING  
 DAVID GJERTSON, PLA, AICP  
 404.200.1858  
 gjertsondesign.com

REVISIONS		
NO.	DATE	DESCRIPTION
1	5.06.22	LANDSCAPE REVISION

**C.E.R.M.**  
 1990 Lakeside Parkway  
 Suite 300  
 Tucker, GA, 30084  
 O: 678.999.0173  
 F: 678.999.0186  
[www.cerm.com](http://www.cerm.com)

PROJECT:  
 PANOLA SHOALS RIVERBANK STABILIZATION AND RESTORATION PROJECT  
 TAX ID: 16 016 03 002  
 LAND LOT 17 16th DISTRICT  
 CITY OF STONECREST  
 DEKALB COUNTY, GEORGIA

**DESIGN TEAM**  
 DESIGN BY: CN  
 DRAWN BY: JD  
 CHECKED BY: YM

CERM PROJECT NO. 1468A-000A  
 CLIENT PROJECT NO. 21-06210-Co018-00

**DATE**  
 JUNE 29, 2022  
**SHEET TITLE**

**LANDSCAPE PLAN WEST**

**SHEET No**  
 C-14-02

C:\Project Operations\Projects\Active Projects\2021-1468A-000A City of Stonecrest South River Stream Bank Restoration\02 Plans\C-14 Landscape Plan.dwg Jul 06, 2022 - 5:25pm

**LEGEND**

- PROPOSED FENCE
- CONTRACTOR'S LAYDOWN AREA



MATCHLINE SHEET C-14-02

N

GRAPHIC SCALE

( IN FEET )  
1 inch = 20 ft.

**KEY PLAN**

**C-14-01**      **C-14-02**

**PRIOR TO DIGGING  
VERIFY LOCATION  
OF EXISTING UTILITIES  
AND CONTACT GEORGIA 811  
<https://www.georgia811.com/>**

CLIENT:

**STONECREST**

City of Stonecrest  
3120 Stonecrest Blvd  
Stonecrest, GA 30038  
770-224-0200

REVISIONS		
NO.	DATE	DESCRIPTION

**C · E · R · M**

1990 Lakeside Parkway  
Suite 300  
Tucker, GA, 30084  
O: 678.999.0173  
F: 678.999.0186  
[www.cerm.com](http://www.cerm.com)

PROJECT:

**PANOLA SHOALS RIVERBANK STABILIZATION  
AND RESTORATION PROJECT**  
TAX ID: 16 016 03 002  
LAND LOT 17 16th DISTRICT  
CITY OF STONECREST  
DEKALB COUNTY, GEORGIA

DESIGN TEAM	
DESIGN BY	CN
DRAWN BY	JD
CHECKED BY	YM

CERM PROJECT NO. 1468A-000A  
CLIENT PROJECT NO. 21-06210-Co018-00

**DATE**  
JUNE 29, 2022

**SHEET TITLE**

**LANDSCAPE PLAN  
EAST**

**SHEET No**  
**C-14-01**

C:\Project Operations\Projects\Active Projects\2021-1488A-000A City of Stonecrest South River Stream Bank Restoration\0 - Design Documents\02 Plans\C-14 Landscape Plan.dwg Jul 06, 2022 - 5:29pm

MATCHLINE SHEET C-14-01

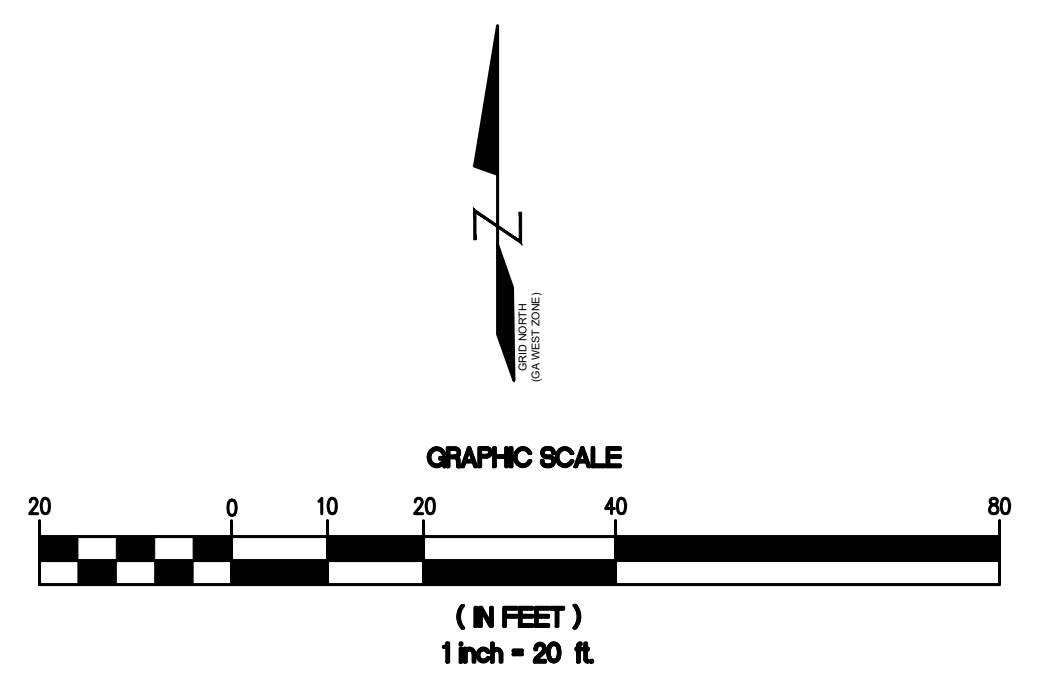

PANOLA SHOALS STREAMBANK RESTORATION - MASTER PLANT LIST												
Unit Cost	Cost	Qty.	Code	Canopy Trees	Botanical Name	Common Name	Caliper	Height	Spread	Root Size	Comments	Spacing
\$150.00	\$0.00		AR3	Canopy Trees	Acer rubrum	American Red Maple	3"	8'-10'	5'-6'	88B		
\$50.00	\$0.00		BN	Canopy Trees	Betula nigra	River Birch	N/A	6'-8'	3'-4'	30 Gal	Multi-trunk, 1" Cal Min.	
\$1,200.00	\$0.00		OP3	Canopy Trees	Quercus phellos	Willow Oak	3"	12'-14'	6'-8'	65 Gal		
\$325.00	\$0.00		TD3	Canopy Trees	Taxodium distichum	Bald Cypress	3"	8'-10'	4'-6'	65B		
\$500.00	\$0.00		LVPS	Canopy Trees	Liriodendron tulipifera	Yellow Poplar	3"	8'-10'	5'-6'	30 Gal		
\$100.00	\$0.00		AA	Accent/Understory Trees	Ametanthe arbores	Downy Serviceberry	N/A	6'-8'	4'-5'	15 Gal		
\$150.00	\$0.00		CXR	Accent/Understory Trees	Cornus x Rutgeri	Stellar Pink Dogwood	N/A	6'-8'	4'-5'	30 Gal	Multi-stem	
\$100.00	\$0.00		JV	Accent/Understory Trees	Juniperus virginiana	Eastern Red Cedar	N/A	4'	2'-3'	7 Gal		
\$225.00	\$0.00		PCC	Accent/Understory Trees	Prunus caroliniana	Cherry Laurel	N/A	6'-8'	4'-5'	15 Gal		
\$20.00	\$0.00		CAM	Large Shrubs	Callicarpa americana	American Beautyberry	24"-36"	18"-24"	3 Gal			4'
\$115.00	\$0.00		CAL	Large Shrubs	Calina arifolia	Sweet Pepperbush	24"-36"	18"-24"	3 Gal			4'
\$30.00	\$0.00		IWW	Large Shrubs	Ilex verticillata	Winterberry	36"	36"	7 Gal			5'
\$15.00	\$0.00		RCB	Large Shrubs	Rhododendron calabresense	Boursault Azalea	36"	36"	7 Gal			5'
\$40.00	\$0.00		VN	Large Shrubs	Viburnum nudum	Smooth Whiteoak	24"-36"	18"-24"	3 Gal			5'
\$15.00	\$0.00		FG	Medium Shrubs	Fothergilla gardenii	Dwarf Fothergilla	18"-24"	18"-24"	3 Gal			3'
\$15.00	\$0.00		HOO	Medium Shrubs	Hydrangea quercifolia	Oakleaf Hydrangea	24"-36"	18"-24"	3 Gal			3'
\$15.00	\$0.00		KOC	Medium Shrubs	Koeleria coccinea	Common Inlily	18"-24"	18"-24"	3 Gal			3'
\$25.00	\$0.00		IVS	Medium Shrubs	Itea virginica	Virginia Sweetgale	24"-36"	18"-24"	3 Gal			3'
\$15.00	\$0.00		CLW	Grasses	Chaetochloa latifolium	Wood Oats	18"-24"	18"	3 Gal			3'
\$15.00	\$0.00		CFA	Grasses	Panicum virgatum	Switch Grass	18"-24"	18"	3 Gal			3'
\$35.00	\$0.00		TD	Grasses	Tripsacum dactyloides	Eastern Gamagrass	24"-36"	18"-24"	3 Gal			3'
\$25.00	\$0.00		AGB	Groundcovers / Vines	Andropogon glomeratus	Bushy Bluestem	12"	6"	1 Gal			18"
\$10.00	\$0.00		WAG	Groundcovers / Vines	Hemerocallis 'Anne Conr'	Anne's Cord	1 Gal					18"
\$10.00	\$0.00		JPN	Groundcovers / Vines	Juncus Procumbens 'Nana'	Spreading Juniper	3 Gal					2.5'
\$10.00	\$0.00		LMB	Groundcovers / Vines	Limonium muscarifolium	Big Blue Linopie	1 Gal					18"
\$10.00	\$0.00		ROM	Groundcovers / Vines	Rosa x Magajoy	Red Luff Rose	1 Gal					2'
\$0.18	\$0.00		SOD	Sod	Zoysia	Zoysia Sod						
\$30.00	\$0.00			Sod	Pine Bark Mutch							

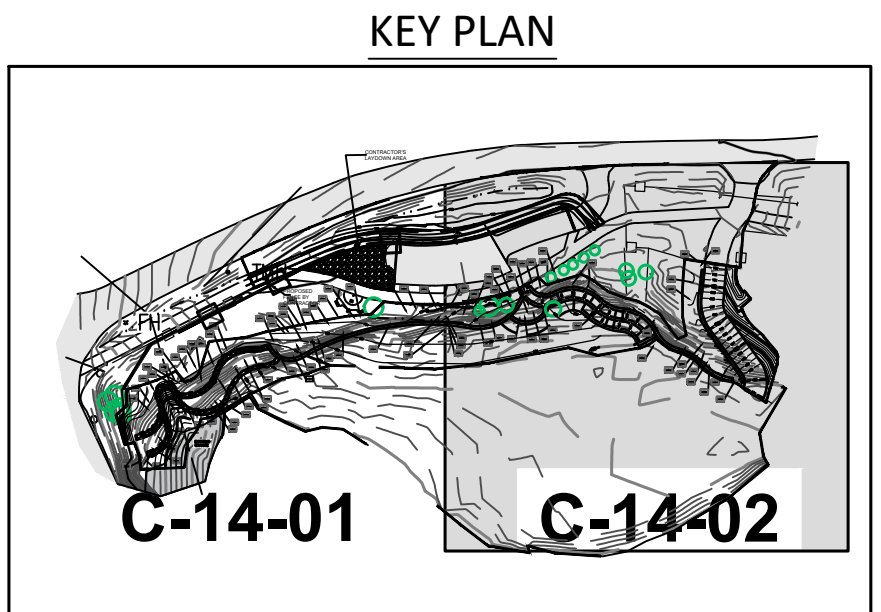

CLIENT:  
  
 City of Stonecrest  
 3120 Stonecrest Blvd  
 Stonecrest, GA 30038  
 770-224-0200

REVISIONS		
NO.	DATE	DESCRIPTION

  
**C · E · R · M**  
 1990 Lakeside Parkway  
 Suite 300  
 Tucker, GA, 30084  
 O: 678.999.0173  
 F: 678.999.0186  
[www.cerm.com](http://www.cerm.com)

PROJECT:  
 PANOLA SHOALS RIVERBANK STABILIZATION  
 AND RESTORATION PROJECT  
 TAX ID: 16 016 03 002  
 LAND LOT 17 16th DISTRICT  
 CITY OF STONECREST  
 DEKALB COUNTY, GEORGIA

DESIGN TEAM	
DESIGN BY	CN
DRAWN BY	JD
CHECKED BY	YM

CERM PROJECT NO. 1468A-000A  
 CLIENT PROJECT NO. 21-06210-Co018-00

DATE  
 JUNE 29, 2022  
 SHEET TITLE

**LANDSCAPE PLAN  
 WEST**

SHEET No  
**C-14-02**

 PRIOR TO DIGGING  
 VERIFY LOCATION  
 OF EXISTING UTILITIES  
 AND CONTACT GEORGIA 811  
<https://www.georgia811.com/>

**NOTES:**

1. IRRIGATION PLANS ARE DIAGRAMMATIC IN NATURE FOR READABILITY PURPOSES. ALL IRRIGATION EQUIPMENT (UNLESS SHOWN IN SLEEVE ON PLANS) SHALL BE INSTALLED INSIDE OF LANDSCAPE AREAS (NOT UNDER HARDSCAPE).
2. ALL SPRINKLERS WILL BE MOUNTED ON (3) MARLEX STREET ELLS WITH A SCHED. 80 NIPPLE SIZE OF SPRINKLER INLET.
3. CONTRACTOR TO UTILIZE A AUTOMATIC DRAIN CHECK VALVE DEVICE WHERE LOW HEAD DRAINAGE MAY OCCUR.
4. ALL WIRE WILL BE COLOR CODED DIRECT BURIAL UL/UF WIRE: TO BE SIZED AS PER CONTROLLER MANUFACTURER'S SPECIFICATIONS.
5. ALL PIPING AND WIRING UNDER HARDTOPS WILL BE IN SCH 40 PVC OR STRONGER PIPE SLEEVE.

CONTRACTOR'S LAYDOWN AREA

1" Irrigation Water Meter. System Requires 30 GPM @ 85 PSI. Irrigation Contractor shall Verify Requirements at Site Before Starting Construction Coordinate with Civil Drawings and notes to determine actual meter location.

PROPOSED FENCE BY CONTRACTOR

MATCHLINE SHEET C-14-02

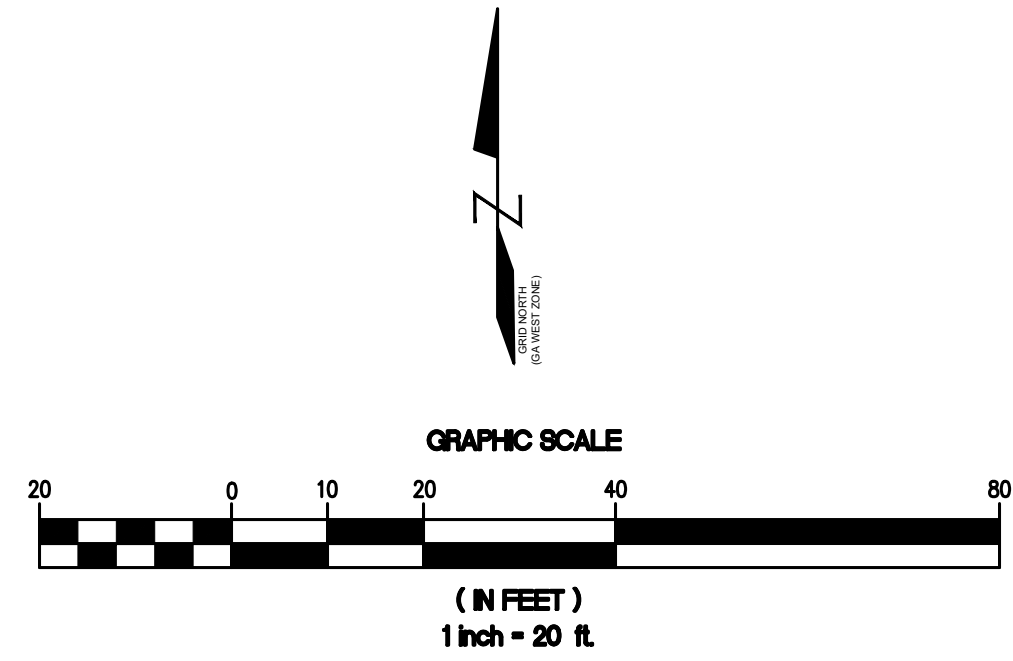

KEY PLAN

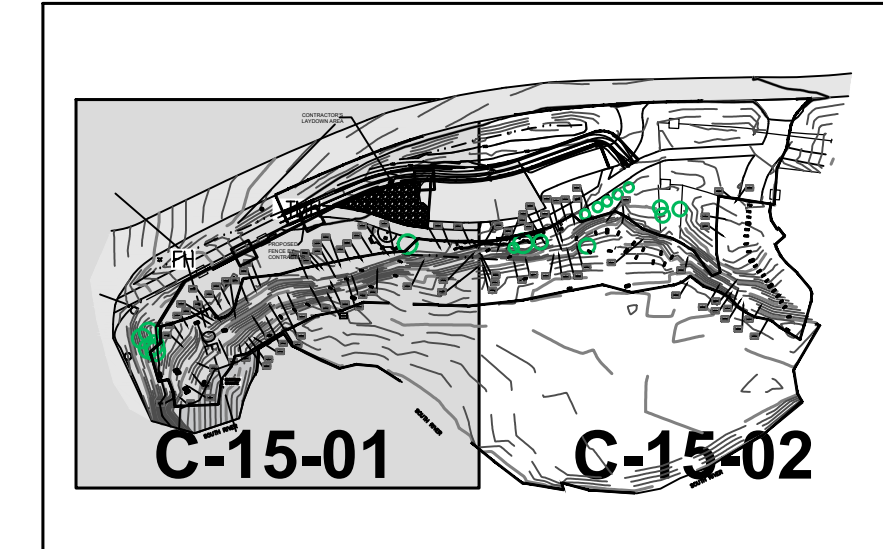

 PRIOR TO DIGGING VERIFY LOCATION OF EXISTING UTILITIES AND CONTACT GEORGIA 811 <https://www.georgia811.com/>

CLIENT:  
  
 City of Stonecrest  
 3120 Stonecrest Blvd  
 Stonecrest, GA 30038  
 770-224-0200

REVISIONS		
NO.	DATE	DESCRIPTION

  
**C · E · R · M**  
 1990 Lakeside Parkway  
 Suite 300  
 Tucker, GA, 30084  
 O: 678.999.0173  
 F: 678.999.0186  
[www.cerm.com](http://www.cerm.com)

PROJECT:  
 PANOLA SHOALS RIVERBANK STABILIZATION AND RESTORATION PROJECT  
 TAX ID: 16 016 03 002  
 LAND LOT 17 16th DISTRICT  
 CITY OF STONECREST  
 DEKALB COUNTY, GEORGIA

DESIGN TEAM	
DESIGN BY	CN
DRAWN BY	JD
CHECKED BY	YM

CERM PROJECT NO. 1468A-000A  
 CLIENT PROJECT NO. 21-06210-Co018-00

DATE  
 JUNE 29, 2022

SHEET TITLE  
**IRRIGATION PLAN EAST**

SHEET No  
**C-15-01**

G:\Project\_Operations\Projects\Active Projects\2021-1468A-000A\_City of Stonecrest\_South River\_Stream Bank\_Restoration\0 - Design Documents\02 Plans\C-15 Irrigation Plan.dwg Jul 06, 2022 - 5:29pm

G:\Project Operations\Projects\Active Projects\2021-1488A-000A City of Stonecrest South River Stream Bank Restoration\0 - Design Documents\02 Plans\C-15 Irrigation Plan.dwg Jul 06, 2022 - 5:29pm

MATCHLINE SHEET C-14-01

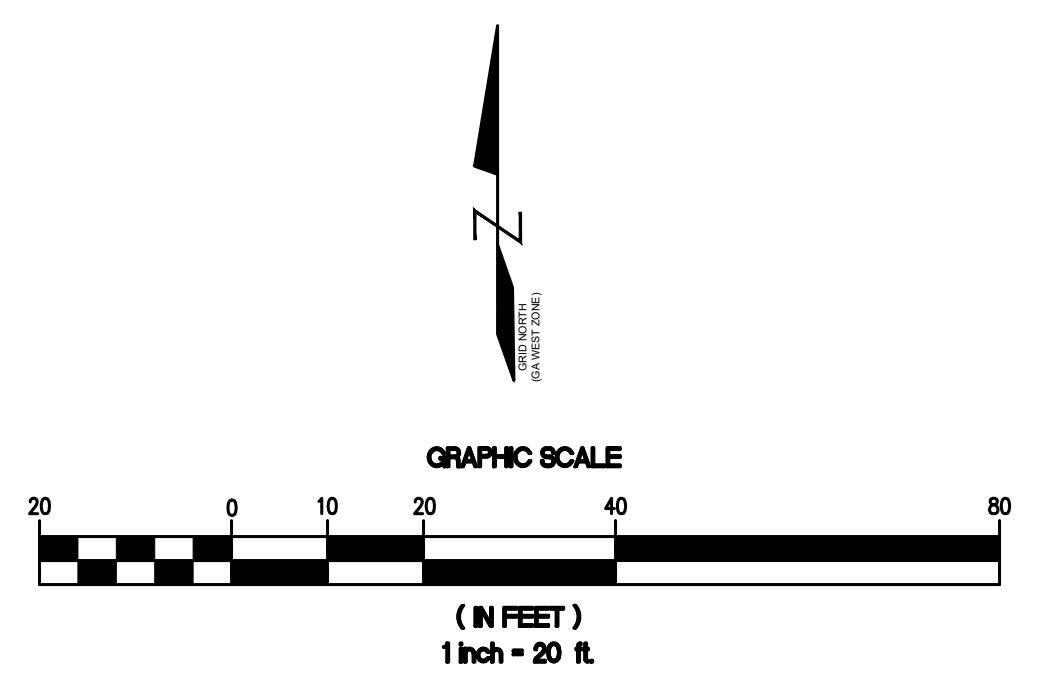

- NOTES:
- IRRIGATION PLANS ARE DIAGRAMMATIC IN NATURE FOR READABILITY PURPOSES. ALL IRRIGATION EQUIPMENT (UNLESS SHOWN IN SLEEVE ON PLANS) SHALL BE INSTALLED INSIDE OF LANDSCAPE AREAS (NOT UNDER HARDSCAPE).
  - ALL SPRINKLERS WILL BE MOUNTED ON (3) MARLEX STREET ELLS WITH A SCHED. 80 NIPPLE SIZE OF SPRINKLER INLET.
  - CONTRACTOR TO UTILIZE A AUTOMATIC DRAIN CHECK VALVE DEVICE WHERE LOW HEAD DRAINAGE MAY OCCUR.
  - ALL WIRE WILL BE COLOR CODED DIRECT BURIAL UL/UF WIRE: TO BE SIZED AS PER CONTROLLER MANUFACTURER'S SPECIFICATIONS.
  - ALL PIPING AND WIRING UNDER HARDTOPS WILL BE IN SCH 40 PVC OR STRONGER PIPE SLEEVE.

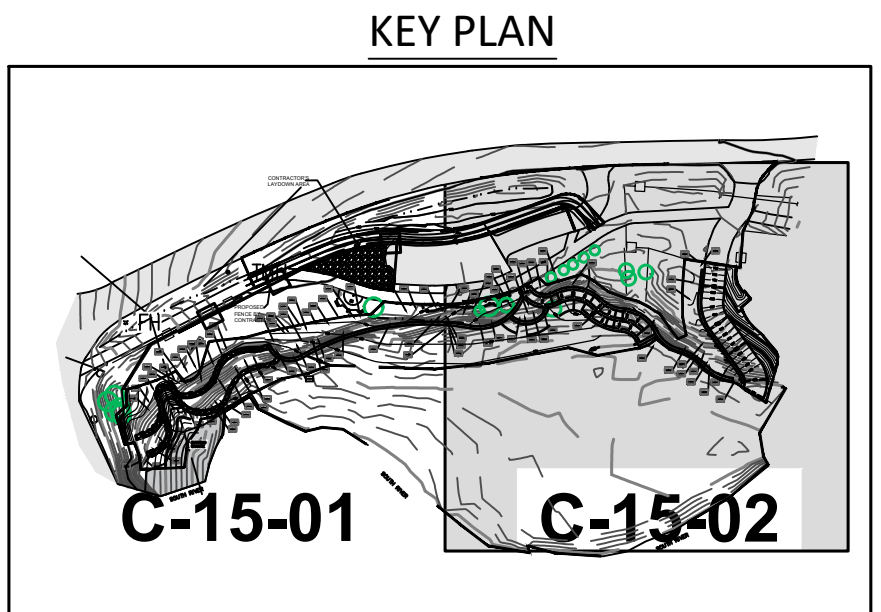

PRIOR TO DIGGING VERIFY LOCATION OF EXISTING UTILITIES AND CONTACT GEORGIA 811 <https://www.georgia811.com/>

CLIENT:  
  
 City of Stonecrest  
 3120 Stonecrest Blvd  
 Stonecrest, GA 30038  
 770-224-0200

REVISIONS		
NO.	DATE	DESCRIPTION

C · E · R · M

1990 Lakeside Parkway  
 Suite 300  
 Tucker, GA, 30084  
 O: 678.999.0173  
 F: 678.999.0186  
[www.cerm.com](http://www.cerm.com)

PROJECT:  
 PANOLA SHOALS RIVERBANK STABILIZATION AND RESTORATION PROJECT  
 TAX ID: 16 016 03 002  
 LAND LOT 17 16th DISTRICT  
 CITY OF STONECREST  
 DEKALB COUNTY, GEORGIA

DESIGN TEAM	
DESIGN BY	CN
DRAWN BY	JD
CHECKED BY	YM

CERM PROJECT NO. 1468A-000A  
 CLIENT PROJECT NO. 21-06210-Co018-00

DATE  
 JUNE 29, 2022

SHEET TITLE  
**IRRIGATION PLAN WEST**

SHEET No  
**C-15-02**

C:\Project\_Operations\Projects\Active Projects\2021-1468A-000A\_City of Stonecrest\_South River\_Stream Bank\_Restoration\0 - Design Documents\02 Plans\C-15 Irrigation\_Plan.dwg Jul 06, 2022 5:29pm

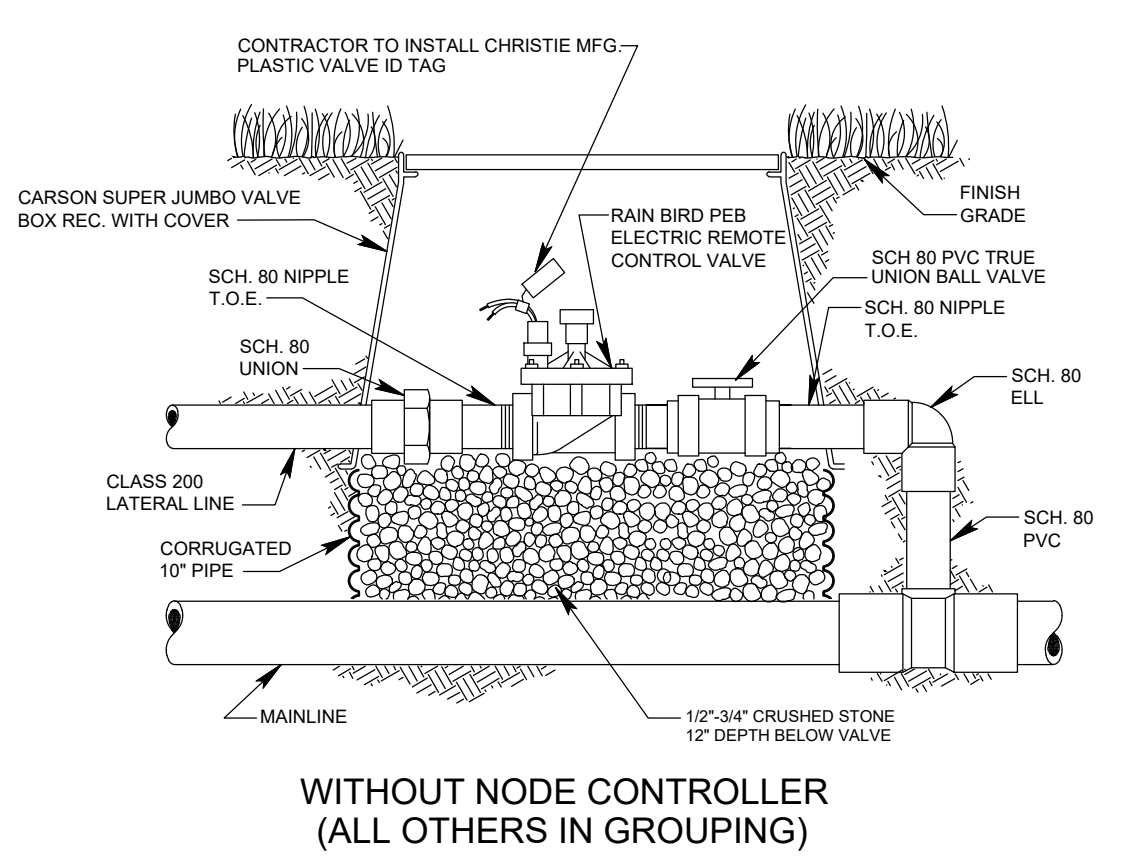
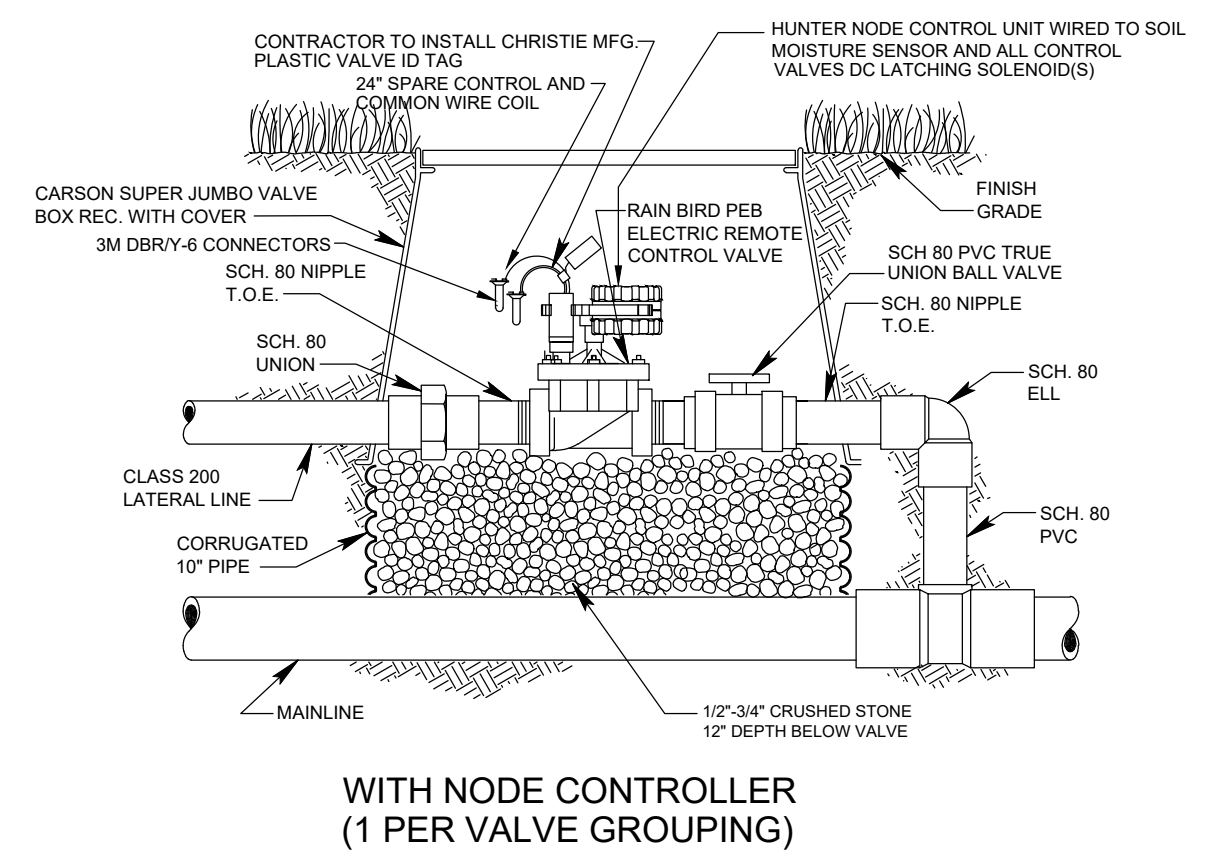

**A CONTROL VALVE**  
NTS

**B SOIL MOISTURE SENSOR**  
NTS

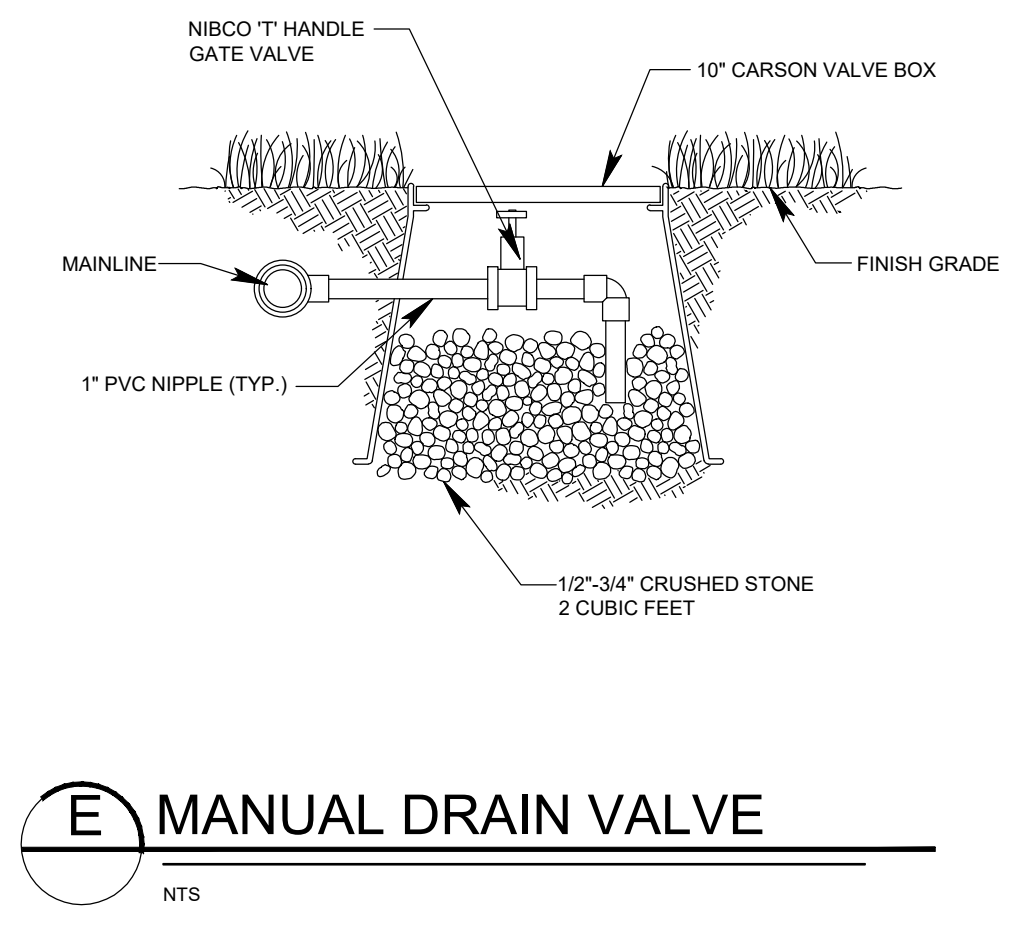
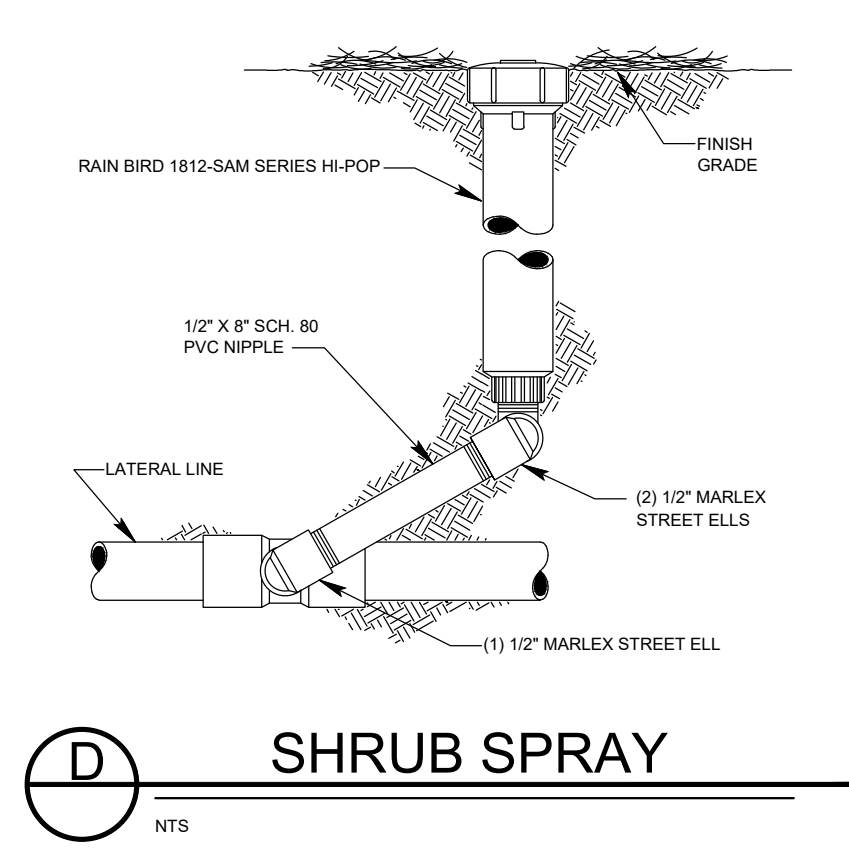
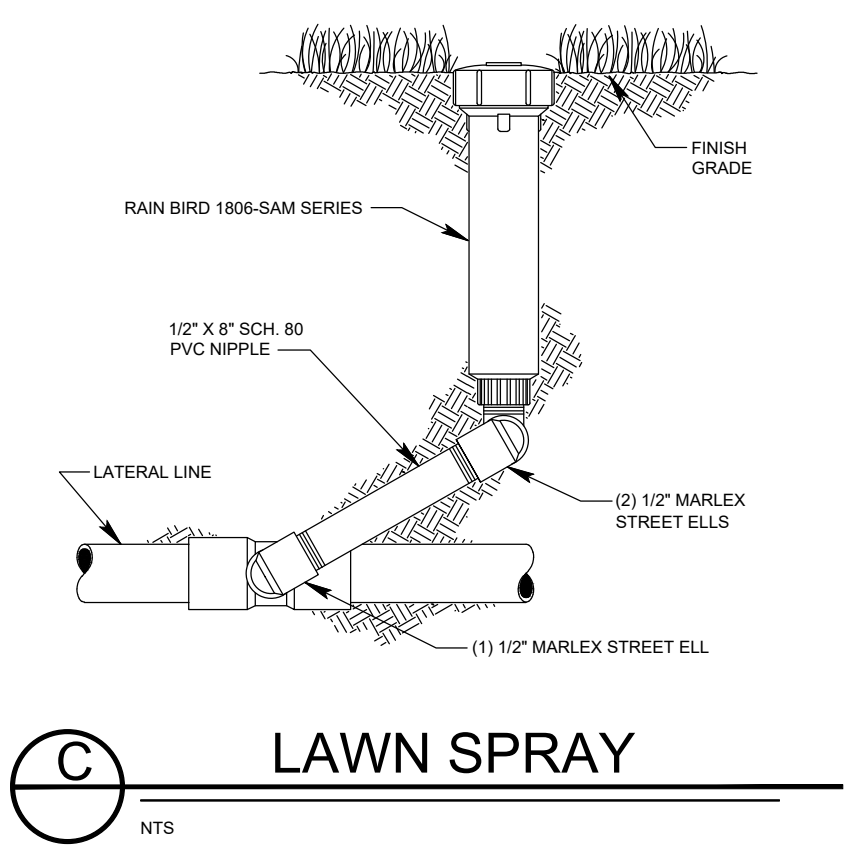

**GENERAL NOTES**

- ALL MAINLINES TO HAVE A MINIMUM OF 18" OF COVER. (SCH 40 PVC PIPE).
- ALL LATERAL AND SUB-MAIN PIPE TO HAVE A MINIMUM OF 12" OF COVER. (SCH 40 PVC PIPE).
- NO ROCKS, BOULDER, OR OTHER EXTRANEIOUS MATERIALS TO BE USED IN BACKFILLING OF TRENCH.
- ALL PIPE TO BE INSTALLED AS PER MANUFACTURERS' SPECIFICATIONS.
- ALL THREADED JOINTS TO BE COATED WITH TEFLON TAPE OR LIQUID TEFLON.
- ALL LINES TO BE THOROUGHLY FLUSHED BEFORE INSTALLATION OF SPRINKLER HEADS.
- SPRINKLER AND RELATED EQUIPMENT TO BE INSTALLED AS PER DETAILS.
- ALL ELECTRICAL JOINTS TO BE MADE USING WATERPROOF CONNECTIONS AS SHOWN ON DETAILS.
- ALL EQUIPMENT NOT SPECIFIED IN THE LEGEND SHALL BE DETERMINED AND FURNISHED BY THE CONTRACTOR.
- NO ELECTRICAL CONNECTIONS SHALL BE MADE IN THE FIELD EXCEPT AT A VALVE CONTROL BOX OR ANOTHER VALVE BOX SPECIFICALLY FOR CONNECTIONS.
- ANY DISCREPANCY BETWEEN THIS SHEET AND OTHERS IN THIS SET MUST BE REFERRED TO THE IRRIGATION CONSULTANT BY THE CONTRACTOR FOR CLARIFICATION BEFORE PRECEEDING WITH THE WORK.
- ALL 24 VOLT WIRE SHALL BE #12 UF/UL FOR COMMON WIRE, AND #14 UF/UL FOR CONTROL WIRES, DIRECT BURIAL, SOLID COPPER (TO BE INSTALLED AS PER BATTERY-OPERATED CONTROLLER MANUFACTURERS' SPECIFICATIONS).
- CONTRACTOR TO BE RESPONSIBLE FOR PROPER COVERAGE OF AREAS TO BE WATERED, I.E. ADJUST HEADS WITH INSUFFICIENT COVERAGE DUE TO BLOCKAGE BY EXISTING OR PROPOSED SITE FEATURES.
- CONTRACTOR TO REFER TO LANDSCAPE PLAN TO KEEP SPRINKLER EQUIPMENT AND ACCESSORY MATERIAL FROM INTERFERING WITH PROPER PLANTING, I.E. VERIFY ROOT BALL SIZE FOR PLANTING.
- CONTRACTOR SHALL PROVIDE EXPANSION COILS AT EACH WIRE CONNECTION IN VALVE BOX (WRAP AROUND 3/4" PIPE 12 TIMES).
- CONTRACTOR TO UTILIZE APPROPRIATE AUTOMATIC DRAIN DEVICE WHERE LOW HEAD DRAINAGE MAY OCCUR.
- ALL SPRINKLERS TO BE MOUNTED ON SWING JOINTS - REFER TO DETAILS.
- CONTRACTOR SHALL UTILIZE VALVE I.D. TAGS ON ALL REMOTE CONTROL VALVES.
- 24 VOLT WIRE SHALL BE COLOR CODED, COMMON-WHITE, CONTROL-RED.
- ALL CONTROLLER/WIRING GROUNDING TO BE AS PER BATTERY-OPERATED CONTROLLER MANUFACTURERS' SPECIFICATIONS.
- ALL MATERIAL TO BE SUPPLIED BY CONTRACTOR TO OWNER:
  - TWO WRENCHES FOR DISASSEMBLING AND ADJUSTING EACH TYPE OF SPRINKLER HEADS AND VALVE SUPPLIED.
  - FIVE VALVE BOX KEYS
  - TWO QUICK COUPLER KEYS WITH MATCHING HOSE SWIVELS.
- SYSTEM IS DIAGRAMMATIC TO IMPROVE CLARITY. ALL MAINLINE PIPING ELECTRIC VALVES AND WIRING ARE TO BE INSTALLED IN LANDSCAPE AREAS AND WITHIN PUBLIC RIGHT-OF-WAY BOUNDARIES. CONTRACTOR SHALL REFERENCE THE LANDSCAPE PLAN PRIOR TO THE INSTALLATION OF PIPING TO AVOID CONTACT WITH PLANT MATERIALS EXISTING OR NEW.
- CONTRACTOR TO ADD EXTENSION RISER TO POP-UP HEADS WHEN NEEDED FOR PROPER COVERAGE.
- CONTRACTOR SHALL INSTALL SPRINKLER EQUIPMENT 12" FROM FOUNDATIONS. ALSO INSTALL SPRINKLERS 4" FROM CURB OR WALKS.
- PRIOR TO BID IRRIGATION CONTRACTOR SHALL VERIFY RIGHT-OF-WAY AND BACKFLOW REQUIREMENTS. NO LATER THAN FIVE DAYS BEFORE BID SUBMITTALS CONTRACTOR SHALL NOTIFY CONSULTANT OF ANY CHANGES FROM PLANS AND SPECIFICATIONS.
- IRRIGATION CONTRACTOR SHALL PROVIDE THE OWNER AND LANDSCAPE ARCHITECT WITH A REPRODUCIBLE CROSS MEASURED AS-BUILT DRAWING OF THE INSTALLED IRRIGATION SYSTEM IN AUTOCAD 2010 FORMAT BEFORE FINAL ACCEPTANCE.
- A 1-YEAR WARRANTY PERIOD SHALL BE PROVIDED FOR SYSTEM AFTER SUBSTANTIAL COMPLETION IS ACCEPTED. START UP AND ADJUSTING OF SYSTEM IN SPRING TIME SHALL BE INCLUDED IN WARRANTY.
- PRIOR TO BID, CONTRACTOR SHALL VERIFY THAT ALL MATERIALS, INSTALLATION PARAMETERS AND OPERATIONS CONFORM TO ALL APPLICABLE CODES AND ORDINANCES. NO LATER THAN FIVE DAYS BEFORE BID SUBMITTALS CONTRACTOR SHALL NOTIFY IRRIGATION CONSULTANT/DESIGNER OF ANY CHANGES REQUIRED DUE TO CURRENT CODE OR ORDINANCE DISCREPANCIES. IF CONTRACTOR DOES NOT COMPLY TO THIS NOTIFICATION, THE CONTRACTOR SHALL BE RESPONSIBLE FOR ALL NECESSARY INSTALLATION CHANGE AND REDESIGN COSTS FOR NON-COMPLIANCE.
- UNLESS OTHERWISE NOTED, THE CONTRACTOR MUST COMPLETE 2 PRESSURE TESTS OF THE IRRIGATION SYSTEM MAINLINE (BOTH TO SHOW NO DROP IN PRESSURE DURING DURATION OF TEST.
  - 2-HOUR PRESSURE TEST AT 1.5 TIMES THE SYSTEM STATIC PRESSURE
  - 24-HOUR PRESSURE TEST AT THE SYSTEM STATIC PRESSURE
- IRRIGATION INSTALLATION CONTRACTOR SHALL PROVIDE OWNER WITH A COLOR-CODED ZONES DIAGRAM PLAN, 8-1/2"x11" LAMINATED SHEET(S), TO IDENTIFY CONTROLLER STATION TO THE CONTROL VALVE NUMBER FOR EACH CONTROLLER, TO BE LOCATED IN ADHESIVE POUCH ATTACHED INSIDE OF CONTROLLER(S).

- NOTES:
- IRRIGATION PLANS ARE DIAGRAMMATIC IN NATURE FOR READABILITY PURPOSES. ALL IRRIGATION EQUIPMENT (UNLESS SHOWN IN SLEEVE ON PLANS) SHALL BE INSTALLED INSIDE OF LANDSCAPE AREAS (NOT UNDER HARDSCAPE).
  - ALL SPRINKLERS WILL BE MOUNTED ON (3) MARLEX STREET ELLS WITH A SCHED. 80 NIPPLE SIZE OF SPRINKLER INLET.
  - CONTRACTOR TO UTILIZE A AUTOMATIC DRAIN CHECK VALVE DEVICE WHERE LOW HEAD DRAINAGE MAY OCCUR.
  - ALL WIRE WILL BE COLOR CODED DIRECT BURIAL UL/UF WIRE: TO BE SIZED AS PER CONTROLLER MANUFACTURER'S SPECIFICATIONS.
  - ALL PIPING AND WIRING UNDER HARDTOPS WILL BE IN SCH 40 PVC OR STRONGER PIPE SLEEVE.

**IRRIGATION LEGEND**

- 1" WATER METER, SYSTEM REQUIRES 30 GPM @ 65 PSI. IRRIGATION CONTRACTOR SHALL BE RESPONSIBLE TO VERIFY THE SYSTEM REQUIREMENTS AT SITE BEFORE STARTING CONSTRUCTION.
- MANUAL DRAIN VALVE. NIBCO T' HANDLE GATE VALVE. DETAIL-E.
- WATTS #909-M1-QT-2", 2" REDUCED PRESSURE ASSEMBLY BACKFLOW PREVENTER. DETAIL-F.
- WINTERIZATION ASSEMBLY. DETAIL-L.
- HUNTER "NODE" BATTERY OPERATED CONTROL SYSTEM TO BE UTILIZED FOR THIS PROJECT - BATTERY-OPERATED CONTROLLER INSTALLED IN VALVE BOX OF ONE ZONE (AND WIRED FROM THERE TO ALL OTHER REMOTE CONTROL VALVES AND MOISTURE SENSOR). REFER TO NOTES ON PLANS. CONTROL UNIT TO BE INSTALLED AS PER INSTALLATION DETAILS AND AS PER MANUFACTURER'S SPECIFICATIONS. DETAILS-A,B.
- INDICATES VALVE WHERE NODE CONTROL DEVICE TO BE INSTALLED
- NOTES:
  - ALL NODE MODULES SHALL BE 4 STATION UNITS
  - INSTALLATION CONTRACTOR SHALL BE RESPONSIBLE TO SEQUENCE CONTROLLER UNITS SO THAT ZONES ARE NOT OPERATING AT THE SAME TIME.
- HUNTER SOIL-CLIK MOISTURE SENSOR. TO BE INSTALLED AS PER INSTALLATION DETAILS AND AS PER MANUFACTURERS' SPECIFICATIONS. ONE SOIL-CLIK MOISTURE SENSOR TO BE INSTALLED FOR EACH NODE CONTROL UNIT. DETAILS-A, B.
- RAIN BIRD 150-PEB PLASTIC ELECTRIC REMOTE CONTROL VALVE, 1 1/2" SIZE, MOUNTED WITH SCH 80 PVC TRUE UNION BALL VALVE, DETAIL-A.
- RAIN BIRD 100-PEB PLASTIC ELECTRIC REMOTE CONTROL VALVE, 1" SIZE, MOUNTED WITH SCH 80 PVC TRUE UNION BALL VALVE, DETAIL-A.
- RAIN BIRD #5 QUICK COUPLING VALVE 1" SIZE. CONTRACTOR TO SUPPLY TWO QCV KEYS AND MATCHING HOSE SWIVELS. DETAIL-K.
- RAIN BIRD 1806-SAM, 6" POP-UP LAWN SPRAY SPRINKLER, 12" RADIUS, FULL-2.0 GPM, HALF-1.0 GPM, QUARTER-0.5 GPM, 30 PSI. DETAIL-C.
- RAIN BIRD 1806-SAM, 6" POP-UP LAWN SPRAY SPRINKLER, 15" RADIUS, FULL-4.0 GPM, HALF-2.0 GPM, QUARTER-1.0 GPM, 30 PSI. DETAIL-C.
- RAIN BIRD 1806-SAM, 6" LAWN POP-UP SIDE STRIP SPRAY SPRINKLER, 9' X 18' RADIUS, 1.5 GPM, 30 PSI. DETAIL-C.
- RAIN BIRD 1806-SAM, 6" LAWN SIDE STRIP SPRAY SPRINKLER, 4' X 30' RADIUS, 1.5 GPM, 30 PSI. DETAIL-C.
- RAIN BIRD 1806-SAM, 6" LAWN END STRIP SPRAY SPRINKLER, 4' X 15' RADIUS, 1.0 GPM, 30 PSI. DETAIL-C.
- RAIN BIRD 1812-SAM, 12" HI-POP SHRUB SPRAY SPRINKLER, 15" RADIUS, FULL-4.0 GPM, HALF-2.0 GPM, QUARTER-3.0 GPM, 30 PSI. DETAIL-D.
- RAIN BIRD 1812-SAM, 12" HI-POP SHRUB SPRAY SPRINKLER, 12" RADIUS, FULL-2.0 GPM, 30 PSI. DETAIL-D.
- RAIN BIRD 1812-SAM, 12" HI-POP SHRUB SIDE STRIP SPRAY SPRINKLER, 9' X 18' RADIUS, 1.5 GPM, 30 PSI. DETAIL-D.
- RAIN BIRD 1812-SAM, 12" HI-POP SHRUB SIDE STRIP SPRAY SPRINKLER, 4' X 30' RADIUS, 1.5 GPM, 30 PSI. DETAIL-D.
- RAIN BIRD 1812-SAM, 12" HI-POP SHRUB END STRIP SPRAY SPRINKLER, 4' X 15' RADIUS, 1.0 GPM, 30 PSI. DETAIL-D.
- HUNTER INDUSTRIES MP ROTATOR SERIES 3000, MOUNTED ON RAIN BIRD 1806-SAM SPRINKLER IN LAWN, 30" RADIUS, FULL-4.0 GPM, HALF-2.0 GPM, QUARTER-1.0 GPM, 40 PSI, DETAIL-C.
- HUNTER INDUSTRIES MP ROTATOR SERIES 2000, MOUNTED ON RAIN BIRD 1806-SAM SPRINKLER IN LAWN, 20" RADIUS, FULL-2.0 GPM, HALF-1.0 GPM, QUARTER-0.5 GPM, 40 PSI, DETAIL-C.
- HUNTER INDUSTRIES MP ROTATOR SERIES 3000, MOUNTED ON RAIN BIRD 1812-SAM SPRINKLER IN BED AREAS, 30" RADIUS, FULL-4.0 GPM, HALF-2.0 GPM, QUARTER-1.0 GPM, 40 PSI, DETAIL-D.
- HUNTER INDUSTRIES MP ROTATOR SERIES 2000, MOUNTED ON RAIN BIRD 1812-SAM SPRINKLER IN BED AREA, 20" RADIUS, FULL-2.0 GPM, HALF-1.0 GPM, QUARTER-0.5 GPM, 40 PSI, DETAIL-D.
- NIBCO T' HANDLE GATE VALVE, SIZED SAME AS MAINLINE, MOUNTED IN CARSON VALVE BOX, DETAIL-R.
- MAINLINE PIPE: 1-1/2" SIZE IF NOT NOTED. SCH 40 PVC SOLVENT WELD PIPE UTILIZING SCH 40 PVC SOLVENT WELD FITTINGS.
- IRRIGATION SLEEVE: SCH 40 PVC, SIZE NOTED ON PLAN. DETAIL-H.
- LATERAL LINE PIPE: SCH 40 PVC SOLVENT WELD PIPE UTILIZING SCH 40 PVC SOLVENT WELD FITTINGS, SIZE NOTED.

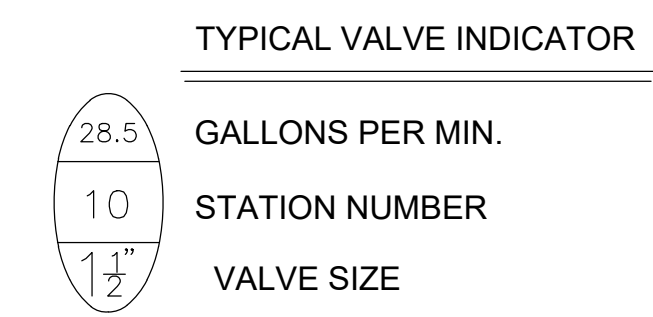

CLIENT:

City of Stonecrest  
3120 Stonecrest Blvd  
Stonecrest, GA 30038  
770-224-0200

REVISIONS		
NO.	DATE	DESCRIPTION

1990 Lakeside Parkway  
Suite 300  
Tucker, GA, 30084  
O: 678.999.0173  
F: 678.999.0186  
[www.cerm.com](http://www.cerm.com)

PROJECT: PANOLA SHOALS RIVERBANK STABILIZATION AND RESTORATION PROJECT  
TAX ID: 16 016 03 002  
LAND LOT 17 16th DISTRICT CITY OF STONECREST DEKALB COUNTY, GEORGIA

DESIGN TEAM	
DESIGN BY	CN
DRAWN BY	JD
CHECKED BY	YM

CERM PROJECT NO. 1468A-000A  
CLIENT PROJECT NO. 21-06210-Co018-00

DATE: JUNE 29, 2022

SHEET TITLE: IRRIGATION DETAILS

SHEET No: C-15-03



G:\Project\_Operations\Projects\Active Projects\2021-1468A-000A City of Stonecrest South River Stream Bank Restoration\40 - Design Documents\02 Plans\C-15 Irrigation Plan.dwg Jul 06, 2022 1:52:39pm

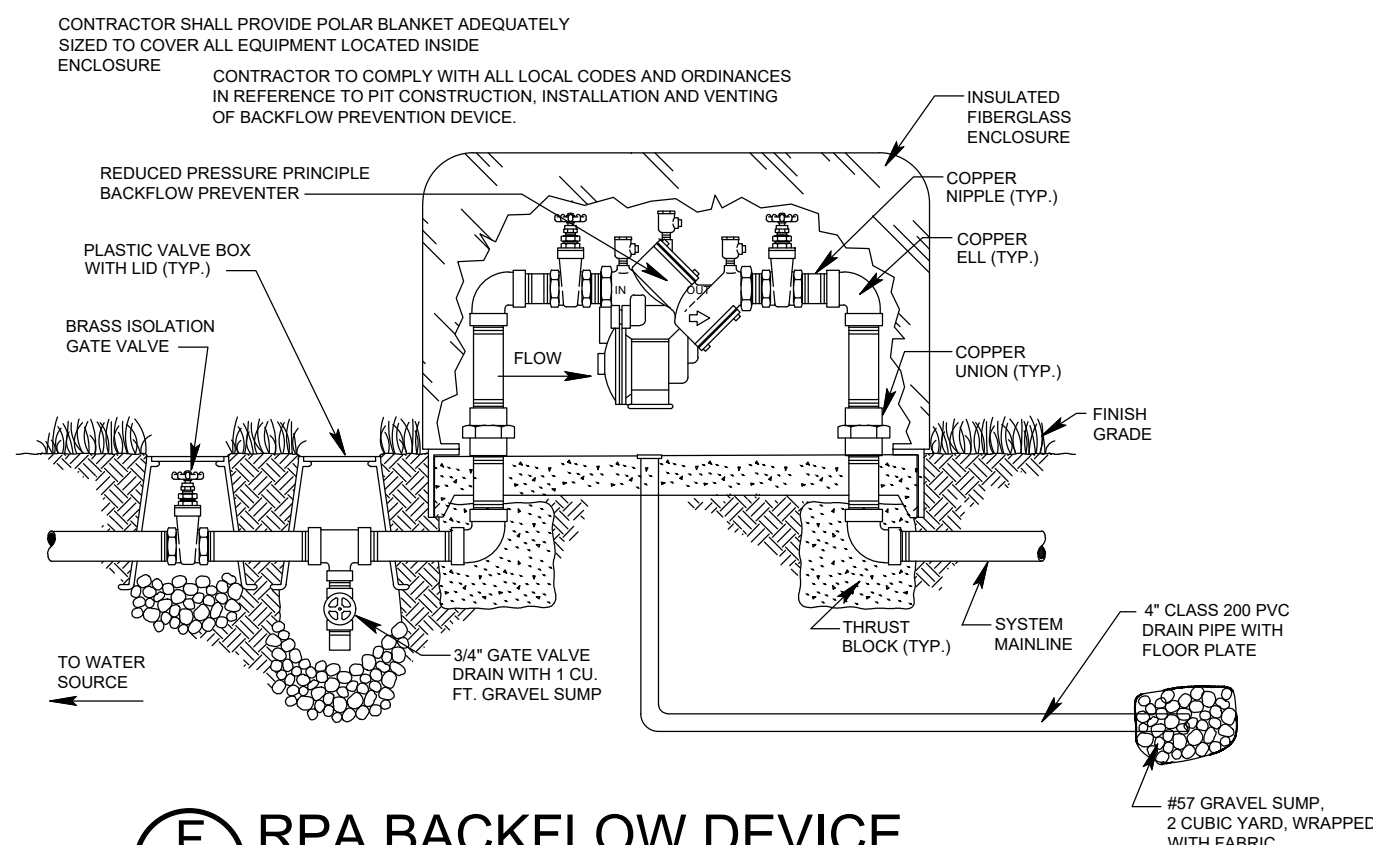

**F RPA BACKFLOW DEVICE**

IRRIGATION CONTRACTOR SHALL SUBMIT BACKFLOW DETAIL TO LOCAL AUTHORITIES FOR APPROVAL BEFORE STARTING CONSTRUCTION.

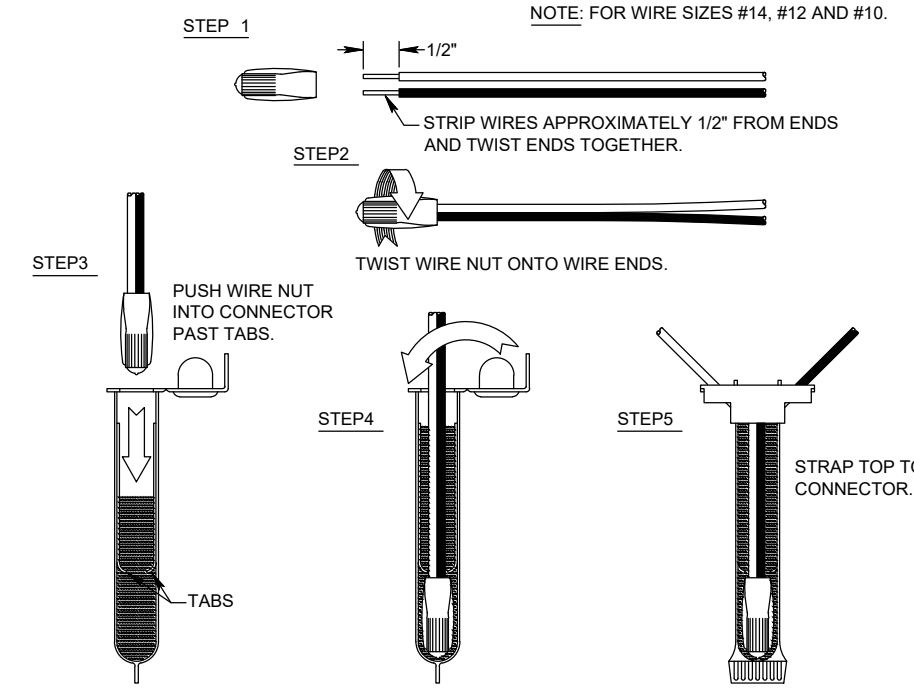

**G WIRE CONNECTION**  
3M-DBRY-Y-6

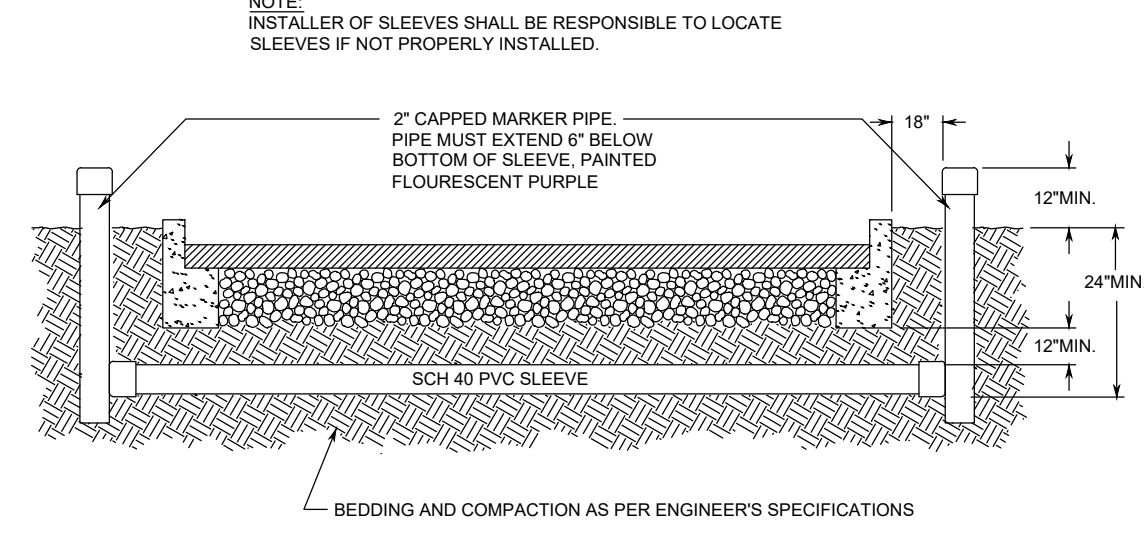

**H SLEEVING**

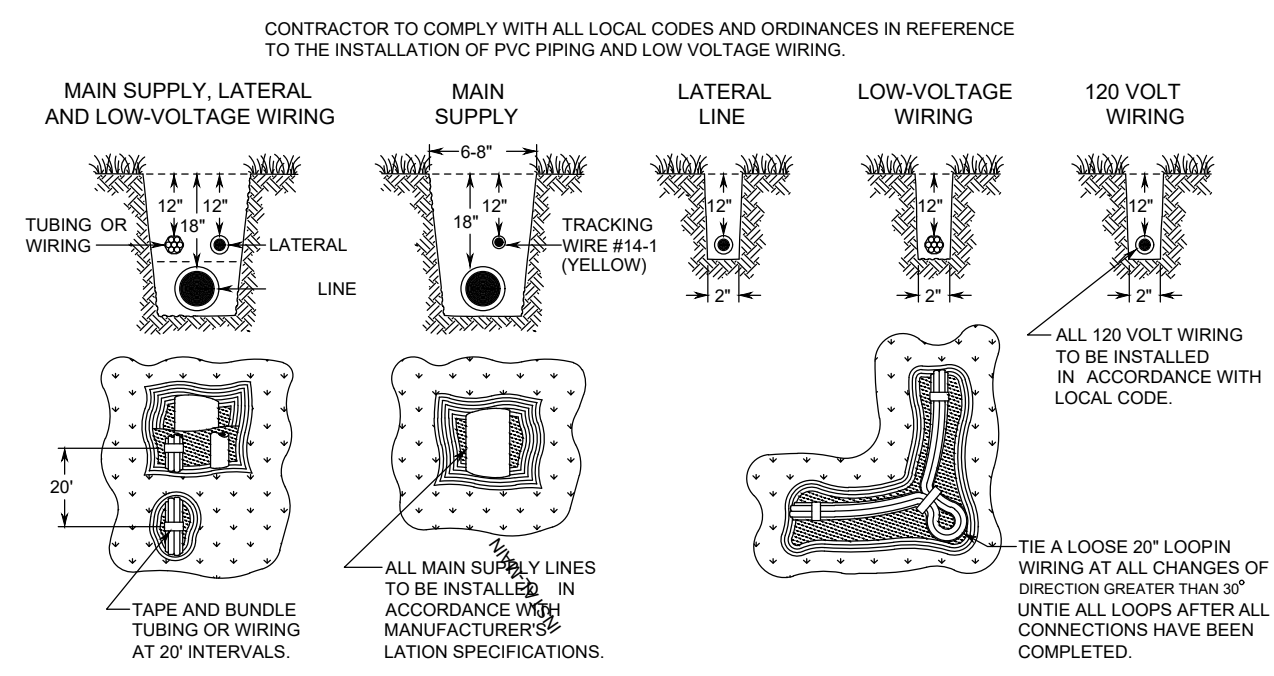

**I TRENCHING**

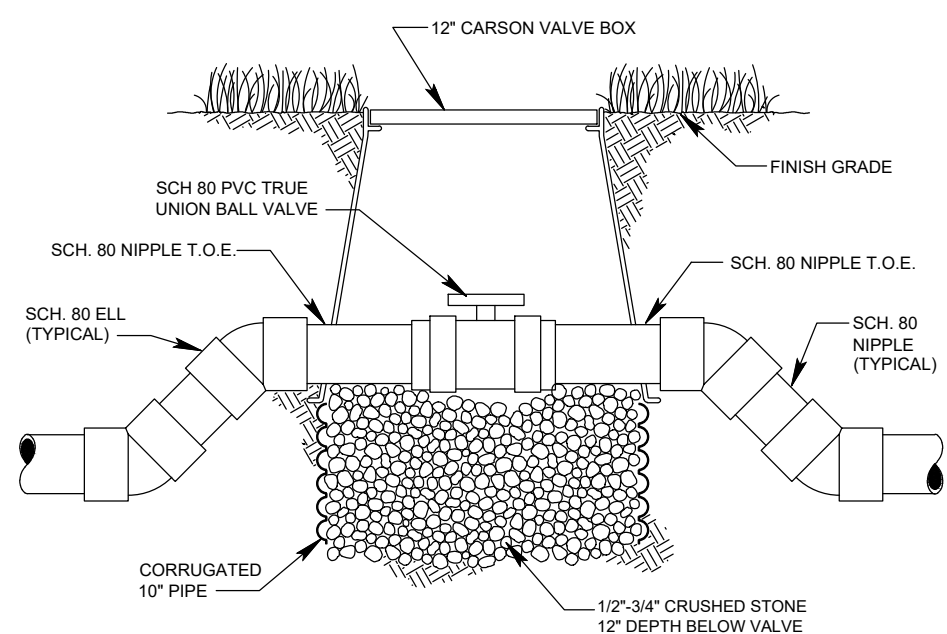

**J ISOLATION BALL VALVE**

VALVE BOX NOTES:  
1. ALL VALVE BOXES TO UTILIZE LOCKABLE COVERS (KEYS TO BE PROVIDED TO OWNER).  
2. ALL VALVE BOXES TO BE BLACK IN COLOR

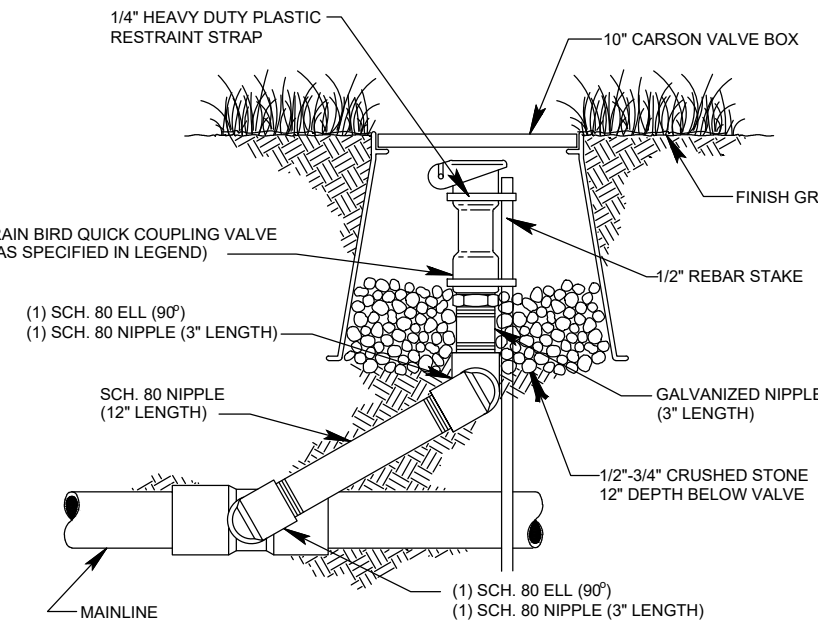

**K QUICK COUPLING VALVE**

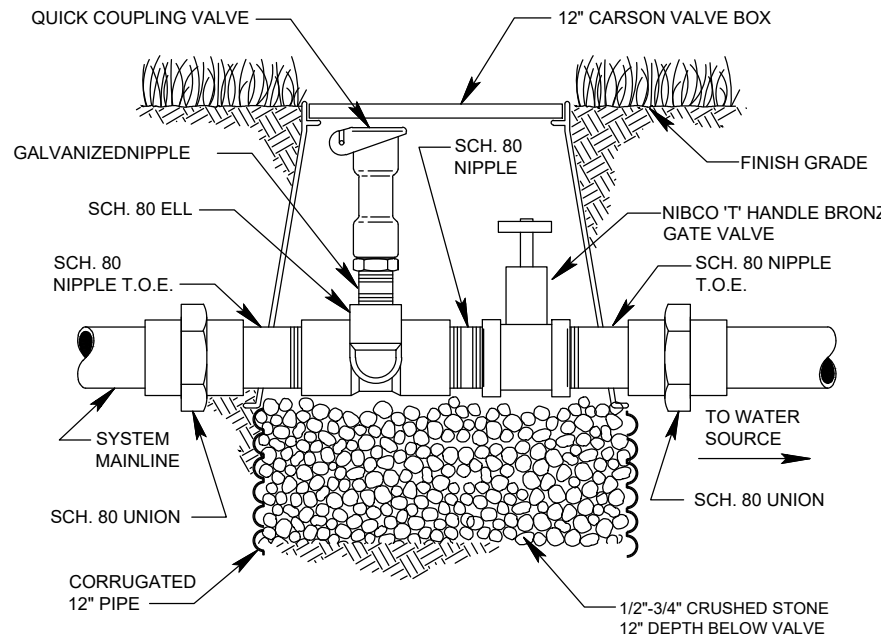

**L WINTERIZATION ASSEMBLY**

CLIENT:  
**STONECREST**  
City of Stonecrest  
3120 Stonecrest Blvd  
Stonecrest, GA 30038  
770-224-0200

REVISIONS		
NO.	DATE	DESCRIPTION



1990 Lakeside Parkway  
Suite 300  
Tucker, GA, 30084  
O: 678.999.0173  
F: 678.999.0186  
[www.cerm.com](http://www.cerm.com)

PROJECT:  
PANOLA SHOALS RIVERBANK STABILIZATION AND RESTORATION PROJECT  
TAX ID: 16 016 03 002  
LAND LOT 17 16th DISTRICT  
CITY OF STONECREST  
DEKALB COUNTY, GEORGIA

DESIGN TEAM	
DESIGN BY	CN
DRAWN BY	JD
CHECKED BY	YM

CERM PROJECT NO. 1468A-000A  
CLIENT PROJECT NO. 21-06210-Co018-00

DATE  
JUNE 29, 2022

SHEET TITLE  
**IRRIGATION DETAILS**

SHEET No  
**C-15-04**



LANDSCAPE IRRIGATION SYSTEM

PART 1- GENERAL

1.1 SYSTEM DESCRIPTION

- A. The sprinkler system shall include sprinklers, valves, piping fittings, controller, wiring, all of sizes and types as shown on the drawings and specified. The system shall be constructed to grades and conform to areas and locations as shown on the drawings.
B. Sprinkler lines shown on the drawings are essentially diagrammatic. Spacing of the sprinkler heads or quick coupling valves are shown on the drawings and shall be exceeded only with written permission of the Designer.
C. Unless otherwise specified or indicated on the drawings, the construction of the sprinkler system shall include the furnishing, installing, and testing of all mains, laterals, risers and fittings, sprinkler heads, gate valves, control valves, controllers, electric wire, controls, backflow preventers, enclosures, and other necessary specialties and the removal and/or restoration of existing improvements, excavating and backfill, and all other work in accordance with the plans and specifications a required for a complete system.

1.2 QUALITY ASSURANCE

- A. Conference: Before any work is started a conference shall be held between the Contractor and the Owner concerning the work under this contract.
B. The Contractor shall maintain continuously a competent superintendent, satisfactory to the Owner, on the work during progress with authority to act or him in all matter pertaining to the work.
C. It is the Irrigation Contractor's responsibility to coordinate and cooperate with the other Contractors to enable work to proceed rapidly and efficiently.
D. The Contractor shall confine his operations to the area to be improved and to the areas allotted him by the Designer and General Contractor for material and equipment.
E. Contractor shall take all necessary to protect the existing site conditions and vegetation.

1.3 SUBMITTALS

- A. General: Submit in accordance with Shop Drawings, Product Data, and Samples.
B. Shop Drawings and Equipment Product Information:
1. Prior to purchasing materials, submit product information on all sprinkler heads, automatic valves, quick coupling valves, controller, and pipe to be used on the project.
2. Contractor shall review drawings and data to supply actual precipitation rates and times for each zone in maintenance package.
3. Prior to trenching, Contractor shall submit proposed trenching equipment to Designer for approval.
C. Record Drawings and Instructions
1. Upon completion of installation, Contractor shall produce as-built drawings in Autocad 2017 format and furnish one set of reproducible and one set of printed record drawings showing all sprinkler heads, valves, drains, and pipelines to scale with dimensions. These drawings shall have dimensions from easily located stationary points (cross measured) as they relate to all valves, mainlines, and wire. Clearly note all approved substitutions of size, material, etc. Complete, concise instruction sheets and parts lists covering all operating equipment and weathering techniques shall be bound into folders and furnished to the Owner in three (3) copies. Submission of this information is a requirement for final acceptance.

1.4 SITE CONDITIONS

- A. The Contractor shall examine the site, plans and specifications (i.e. system requirements).
B. It shall be the Contractor's responsibility to report in writing to the Designer any deviations between drawings, specification, and actual site conditions. Failure to do so prior to the installing of equipment shall be done at the Contractor's expense.
C. Adjustment of the sprinkler heads and automatic equipment will be done by the Contractor, upon completion of installation, to provide optimum performance.
D. After completion, testing, and acceptance of the system, the Contractor shall verbally instruct the Owner's personnel in the operation and maintenance of the system. All written instruction shall be included in the bound maintenance package as stated in Paragraph 1.3 - Submittals.

PART 2 - PRODUCTS

2.1 PIPE AND FITTINGS

- A. Pipe sizes shall conform to those shown on the drawings. No substitutions of smaller pipe sizes will be permitted, but substitutions of larger size may be approved. All pipe damaged or rejected because of defects shall be removed from the site at the time of said rejection.
B. All piping downstream of electric valves shall be rigid unplasticized Sch 40 PVC pipe extruded from virgin parent material of the type specified on the drawings. The pipe shall be homogeneous throughout and free from visible cracks, holes, foreign materials, blisters, wrinkles and permanently marked with the manufacture's name, material, size, and schedule type. Pipe must bear the NFS seal.
C. All mainline piping and underground piping under continuous pressure shall be rigid unplasticized Sch 40 PVC pipe extruded from virgin parent material of the type specified on the drawings. The pipe shall be homogeneous throughout and free from visible cracks, holes, and foreign materials, blisters, wrinkles and dents.
D. All plastic fittings to be installed shall be molded fittings manufactured of the same material as the pipe and shall be suitable for solvent weld, slip joint ring tight seal, or screwed connections NO fitting made of other material shall be used except as hereinafter specified.
E. Slip fitting socket tapers shall be so sized that a dry unsoftened pipe end conforming to these special provisions can be inserted no more than halfway into the socket. Plastic saddle and flange fittings will not be permitted. Only Schedule 80 pipe may be threaded.

2.2 SLEEVES

- A. All sleeves shall be Sch 40 PVC or stronger. All sleeves are required at every crossing indicated on drawings. (Size Noted)
B. All sleeves shall be installed under proposed pavement areas prior to subgrade and base construction.
C. Sleeves shall have a minimum horizontal separation of 18" and a maximum of eighteen (18) inch clearance below bottom of curb.
D. All sleeves shall have a minimum horizontal separation of twenty-four (24) and maximum of thirty-six inches from center to center.
E. Stub up sleeve pipe twelve (12) inches above ground surface and cap. Paint cap with fluorescent orange paint for easy identification.
F. The location of all sleeves shown on the plans is schematic. The contractor shall make any adjustments necessary to accommodate existing vegetation, utilities, or other existing conditions.
G. If the road crossings are designated as being bore locations the bore must be ample size to accommodate the size sleeve specified.

2.3 CONTROL SYSTEM

- A. The controllers for the system shall be battery-operated controls (housed inside control valve valve box) as specified on plans.
B. Install Moisture sensors (as specified on plans) to override irrigation system during times of rain.

2.4 CONTROL WIRE

- A. Control wire shall be type UF, UL approved, for direct burial and shall be gauge 14 or larger for the control wire and gauge 12 or larger for common wire.
B. Joining of underground wires shall be made with watertight connectors in valve boxes. No splicing between boxes is acceptable. Utilize 3M DBRY-6 Connections unless directed otherwise.
A. All wire connections in valve boxes; first example shall stay open until the Designer approves.

2.5 IRRIGATION VALVES

- A. Zone Control Valves
1. Globe-type diaphragm valves of normally closed design, with heavy-duty plastic and covers (type noted on drawings). Operation accomplished by means of an integrally mounted heavy-duty 24 volt AC solenoid complying with National Electrical Code, Class II Circuit, solenoid coil potted in epoxy resin within a plastic-coated stainless steel housing. Solenoids shall be completely waterproof, suitable for direct underground burial. Provide a flow stem adjustment in each valve.
2. Drip Control Valves shall be prefabricated assemblies as specified on plans.

2.6 VALVE BOXES

- A. All valves shall be installed in thermoplastic valve access boxes of the size required to permit access to the valve. Valve boxes shall include black thermoplastic locking covers. Manufacturer - Carson or approved equal.
B. All valve boxes shall be installed on at least a two (2) cubic foot gravel base to provide foundation and drainage.
C. All valve box elevations shall be 1/2" below finished grade.

2.7 THRUST BLOCKS

- A. Place one cubic ft. of concrete for each inch of pipe diameter for thrust block. Thrust shall not allow vertical or horizontal movement of pipe in any direction unless otherwise noted on design. Thrust blocking shall be provided on all piping three (3) inch diameter and larger. If area is not able to be access, thrust block Harco Ductile Iron restraints shall be required for both fitting and pipe.

2.8 DRIP EQUIPMENT

- A. Drip tubing shall be as specified on plans (type, emitter flow, emitter spacing, etc).
B. All miscellaneous drip equipment required for proper operation must be installed (i.e. air vent valves, drip flush tubes, staking, etc).

PART 3 - EXECUTION

3.1 EXCAVATION AND BACKFILL

- A. Trenches for pipe sprinkler lines shall be excavated of sufficient depth and width to permit proper handling and installation by any other method the Contractor may desire if approved by the Owner, pipe manufacturer, and Designer. The backfill shall be thoroughly compacted and evened off with the adjacent soil level. Selected fill dirt or sand shall be used if soil conditions are rocky. In rocky areas the trenching depth shall be two (2) inches below normal trenching depth to allow for this bedding. The fill dirt or sand shall be used in filling (4) inches above the pipe. The remainder of the backfill shall contain no lumps or rocks larger than three (3) inches. The top twelve (12) inches of backfill shall be topsoil, free of rocks, subsoil, or trash. Any open trenches or partially backfilled trenches left overnight or left unsupervised shall be barricaded to prevent undue hazard to the public. The Contractor shall backfill in six (6) inch compacted lifts as needed to bring the soil to its original density.
C. In the spring following the year of installation, the Contractor shall repair any settlement of the trenches by bringing them to grade with topsoil, and seeding with the existing lawn type(s). Watering and maintenance of the repaired areas shall be the Owner's responsibility.

3.2 INSTALLATION OF PLASTIC PIPE

- A. Plastic pipe shall be installed in a manner that permits expansion and contraction as recommended by the manufacturer.
B. Plastic pipe shall be cut with a handsaw or hacksaw with the assistance of a square in sawing vice or in a manner so as to ensure a square cut. Burrs at cut ends shall be removed prior to installation so that a smooth unobstructed flow will be obtained.
C. All plastic-to-plastic joints shall be solvent weld joints or slip seal joints. Only the solvent recommended for the pipe and fittings shall be installed as outlined and instructed by the pipe manufacturer. The Contractor shall assume full responsibility for the correct installation.
D. The joints shall be allowed to set at least twenty-four (24) hours before pressure is applied to the system on PVC pipe.

3.3 CONTROLLER AND ELECTRICAL CONNECTIONS

- A. All electrical connections shall conform to the National Electrical Code, latest edition.
B. Control wires installed beneath walks, drives, or other permanent surfaces shall be placed in sleeves.
C. Wires shall be spliced only at valve boxes.
D. Leave twenty-four (24) inch loop of wire at each valve for expansion/contraction and servicing.
E. Controllers and valves shall be from the same company e.g. (Rain Bird, Toro or approved equal).

3.4 FLUSHING AND TESTING

- A. After all new sprinkler piping and risers are in place and connected for a given section and all necessary division work has been completed and prior to the installation of sprinkler heads all control valves shall be opened and a full head of water used to flush out the system.
B. Sprinkler main shall be pressure tested as follows:
1. Two (2) hour pressure test at 1.5 times the system operating pressure; maximum of 130 PSI
2. Twenty four (24) hour pressure test at the system operating pressure
If leaks occur, repair and repeat the test until no leaks occur (pressure does not drop). Give Designer twenty-four hours notice prior to testing.
C. Testing of the system shall be performed after completion of the entire installation and any necessary repairs shall be made at the Contractor's expense to put the system in good working order before final payment by the Owner.
D. Adjustment of the sprinkler heads, and automatic equipment, will be done by the Contractor upon completion of installation to provide optimum performance. Minor adjustments during the guarantee period will be made by the Owner.
E. After completion, testing, and acceptance of the system, the Contractor will instruct the Owner's personnel in the operation and maintenance of the system.

3.5 CLEAN UP AND PROTECTION

- A. During irrigation work, Contractor shall keep project site clean and orderly
B. Upon Completion of Work, clear grounds of debris, superfluous materials and all equipment. Remove from site to satisfaction of the Owner's Representative.

3.6 WINTERIZING THE SYSTEM

- A. Contractor's responsibility to winterize the irrigation system the first and second winter following Substantial Completion of the Project.

3.7 INSPECTION

- A. Periodic inspections will be made by the Landscape Architect/Owner's Representative to review the quality and progress of the work. Work found to be unacceptable must be corrected within a timely mater (to be determined by Owner's Representative). Remove rejected materials promptly from the project site.
B. It will be the responsibility of the Irrigation Contractor to provide a reliable communication system (i.e. Two way radios or remote radio control activation system) for Substantial Completion and all periodic inspections.

PART 4.0 - CODES, PERMITS, WARRANTY, AND GUARANTEE

4.1 CODES AND ORDINANCES

- A. All materials, installation parameters, and operations shall conform to all applicable codes and ordinances. It is the Contractor's responsibility to investigate and follow all regulations. Contractor is responsible to verify applicable codes and ordinances prior to submitting bid. Before bid submittal, it is the Contractor's responsibility to notify the Irrigation Consultant/Designer at least 5 days before bid submittal, of any changes due to code or ordinance discrepancies. If the Contractor does not comply with this process and notification, the Contractor shall be responsible for the necessary installation change and redesign costs for non-compliance.

4.2 PERMITS AND FEES

- A. The Contractor shall obtain, at his expense, all required permits and shall pay all required fees. Any penalties imposed due to failure to obtain any permit or pay any fee shall be the responsibility of the Contractor.

4.3 WARRANTY AND GUARANTEE

- A. The Contractor shall furnish a certificate of warranty registration and a written guarantee of work and materials for a one year period from the date of final acceptance of the Irrigation System by the Owner and the Designer.

END OF SECTION

CLIENT:



City of Stonecrest
3120 Stonecrest Blvd
Stonecrest, GA 30038
770-224-0200

Table with 3 columns: NO., DATE, DESCRIPTION. Title: REVISIONS



CERM

1990 Lakeside Parkway
Suite 300
Tucker, GA, 30084
O: 678.999.0173
F: 678.999.0186
www.cerm.com

PANOLA SHOALS RIVERBANK STABILIZATION AND RESTORATION PROJECT
TAX ID: 16 016 03 002
LAND LOT 17 16th DISTRICT
CITY OF STONECREST
DEKALB COUNTY, GEORGIA

PROJECT:

Table with 2 columns: DESIGN TEAM, DESIGN BY, DRAWN BY, CHECKED BY

CERM PROJECT NO. 1468A-000A
CLIENT PROJECT NO. 21-06210-Co018-00

DATE
JUNE 29, 2022

SHEET TITLE

IRRIGATION NOTES

SHEET No
C-15-05



PRIOR TO DIGGING
VERIFY LOCATION
OF EXISTING UTILITIES
AND CONTACT GEORGIA 811
https://www.georgia811.com/

C:\Project\_Operations\Projects\Active Projects\2021-1468A-000A\_City of Stonecrest\_South River\_Stream Bank Restoration\40 - Design Documents\02 Plans\C-15 Irrigation Plan.dwg Jul 06, 2022 - 5:30pm